

S13-1-329r18  
21 November 2011  
Doc. TSG-876r1  
2 December 2010

**Working Draft:  
ATSC Candidate Standard:  
Non-Real-Time Content Delivery**

**Advanced Television Systems Committee**  
1776 K Street, N.W.  
Suite 200  
Washington, D.C. 20006  
[www.atsc.org](http://www.atsc.org)

The Advanced Television Systems Committee, Inc., is an international, non-profit organization developing voluntary standards for digital television. The ATSC member organizations represent the broadcast, broadcast equipment, motion picture, consumer electronics, computer, cable, satellite, and semiconductor industries.

Specifically, ATSC is working to coordinate television standards among different communications media focusing on digital television, interactive systems, and broadband multimedia communications. ATSC is also developing digital television implementation strategies and presenting educational seminars on the ATSC standards.

ATSC was formed in 1982 by the member organizations of the Joint Committee on InterSociety Coordination (JCIC): the Electronic Industries Association (EIA), the Institute of Electrical and Electronic Engineers (IEEE), the National Association of Broadcasters (NAB), the National Cable Television Association (NCTA), and the Society of Motion Picture and Television Engineers (SMPTE). Currently, there are approximately 170 members representing the broadcast, broadcast equipment, motion picture, consumer electronics, computer, cable, satellite, and semiconductor industries.

ATSC Digital TV Standards include digital high definition television (HDTV), standard definition television (SDTV), data broadcasting, multichannel surround-sound audio, and satellite direct-to-home broadcasting.

---

*Note:* The user's attention is called to the possibility that compliance with this standard may require use of an invention covered by patent rights. By publication of this standard, no position is taken with respect to the validity of this claim or of any patent rights in connection therewith. One or more patent holders have, however, filed a statement regarding the terms on which such patent holder(s) may be willing to grant a license under these rights to individuals or entities desiring to obtain such a license. Details may be obtained from the ATSC Secretary and the patent holder.

---

This specification is being put forth as a Candidate Standard (CS) by the Specialist Group on Data Broadcast (TSG/S13). This document was elevated to CS by TSG on 20 October 2010. All ATSC members and non-members are encouraged to review and implement this specification and return comments to [cs-editor@atsc.org](mailto:cs-editor@atsc.org). ATSC Members can also send comments directly to the TSG/S13 Specialist Group. This specification is expected to progress to Proposed Standard prior to the close of the CS period on 28 February 2011. This Candidate Standard may be revised during this period.

## Table of Contents

<b>1. SCOPE</b>	<b>9</b>
1.1 Introduction and Background	9
1.2 Organization	10
<b>2. REFERENCES</b>	<b>10</b>
2.1 Normative References	10
2.2 Informative References	13
<b>3. DEFINITION OF TERMS</b>	<b>14</b>
3.1 Compliance Notation	14
3.2 Treatment of Syntactic Elements	14
3.2.1 Reserved Elements	14
3.3 Acronyms and Abbreviations	15
3.4 Terms	17
3.5 Extensibility	17
3.5.1 Descriptor Processing Considerations	18
3.6 XML Schema and Namespace	18
<b>4. SYSTEM OVERVIEW</b>	<b>19</b>
4.1 System Architecture	19
4.1.1 Fixed-Broadcast NRT System Architecture	19
4.1.2 Mobile Broadcast NRT System Architecture	22
4.2 Content Item Concept	23
4.3 Consumption Models	23
<b>5. CONTENT DELIVERY SPECIFICATIONS</b>	<b>24</b>
5.1 IP Delivery	24
5.1.1 ATSC Fixed	24
5.1.2 ATSC Mobile	26
5.2 FLUTE File Delivery	26
5.3 FLUTE FDT Extensions for Linkage of Files to Content Items	27
5.4 Forward Error Correction (FEC)	29
5.4.1 Symbol Encoding Algorithm	29
5.4.2 ATSC NRT Raptor Parameter Derivation Algorithm for Content Delivery Protocol	29
5.5 FDT Instance Compression	30
5.6 File Compression	31
5.7 ZIP Archive Format	31
5.7.1 Extension Structure	31
5.7.2 ATSC NRT Extensions	32
5.8 Filename Extensions and Internet Media Types	33

---

5.9	File Names and Hyperlink Resolution	36
5.10	Buffer Model	37
5.11	Content Update Notification	37
5.11.1	Update Notification	38
5.12	File Delivery to Support RME Streams	39
<b>6.</b>	<b>SIGNALING AND ANNOUNCEMENTS FOR FIXED NRT BROADCASTS</b>	<b>39</b>
6.1	Non-Real-Time Services	39
6.1.1	Standalone NRT Services	40
6.1.2	Adjunct NRT Services	40
6.1.3	NRT Protocol Version Identification	40
6.1.4	Service Signaling Channel	40
6.1.5	Structure of SSC Tables	41
6.2	Service Map Table (SMT)	41
6.2.1	Subnet-Level SMT Descriptors	42
6.2.2	Service-Level SMT Descriptors	43
6.2.3	Component-Level SMT Descriptors	44
6.3	Non-Real-Time Information Table (NRT-IT)	45
6.4	Text Fragment Table (TFT)	52
6.5	Purchase Information Tables	55
6.5.1	Purchase Item Table	55
6.5.2	Purchase Terms and Channels Table	59
<b>7.</b>	<b>SIGNALING AND ANNOUNCEMENTS FOR MOBILE NRT BROADCASTS</b>	<b>64</b>
7.1	Signaling for Mobile NRT Broadcasts	64
7.1.1	Overview	64
7.1.2	Background on ATSC-M/H Signaling	64
7.1.3	Signaling NRT Services in the Service Map Table	65
7.1.4	SMT-MH Descriptors	66
7.1.5	Mapping FLUTE Files to Content Elements in the Service Guide	67
7.2	Announcement for Mobile NRT Broadcasts	67
7.2.1	Overview	67
7.2.2	Relationship to Mobile NRT Signaling	67
7.2.3	Approach for Announcing Mobile NRT Services and Content	68
7.2.4	ATSC Mobile NRT Service Guide Data Model	68
<b>8.</b>	<b>BASIC DESCRIPTORS</b>	<b>84</b>
8.1	Protocol Version Descriptor (PVD)	84
8.2	NRT Service Descriptor	86
8.3	Capabilities Descriptor	87
8.4	Icon Descriptor	91
8.5	ISO-639 Language Descriptor	92

8.6	FLUTE Component Descriptor Extension	93
8.7	Time Slot Descriptor	94
8.8	Internet Location Descriptor	96
8.9	Associated Service Descriptor	97
<b>9.</b>	<b>RECEIVER TARGETING</b>	<b>98</b>
9.1	Introduction	98
9.2	Receiver Targeting Descriptor	98
9.3	Receiver Targeting XML Element	100
9.4	Targeting Criterion Table	103
<b>10.</b>	<b>INTERACTION CHANNEL</b>	<b>106</b>
	<b>ANNEX A CAPABILITY CODE DETAILS</b>	<b>107</b>
A.1	Overview of capability signaling	107
A.2	List of Capability Codes with semantics	108
A.2.1	Capability Code 0x10: Compact No-Code FEC Scheme	109
A.2.2	Capability Code 0x11: Raptor Algorithm	109
A.2.3	DECE CFF Multimedia Container Format	109
A.2.4	Capability Code 0x25: ISO Base Media File Format for AAC Audio	110
A.2.5	Capability Code 0x26: ATSC Compliant MPEG-2 Transport Stream	111
A.2.6	Capability Code 0x41: AVC Standard Definition Video	111
A.2.7	Capability Code 0x42: AVC High Definition Video	111
A.2.8	Capability Code 0x43: AC-3 Audio	111
A.2.9	Capability Code 0x44: Enhanced AC-3 Audio	111
A.2.10	Capability Code 0x45: MP3 Audio	113
A.2.11	Capability Code 0x46: Browser Profile A	113
A.2.12	Capability Code 0x48: Atom	113
A.2.13	Capability Code 0x49: AVC Mobile Video	113
A.2.14	Capability Code 0x4A: HE AAC v2 Mobile Audio	113
A.2.15	Capability Code 0x4B: HE AAC v2 Profile, Level 4 Audio	113
A.2.16	Capability Code 0x4C: DTS-HD Audio	113
A.2.17	Capability Code 0x4D: CFF-TT	114
A.2.18	Capability Code 0x4E: CEA 708 Captions	114
A.2.19	Capability Code 0x4F: HE AAC v2 Audio with MPEG Surround	114
	<b>ANNEX B NRT SERVICE CATEGORIES</b>	<b>115</b>
B.1	Introduction	115
B.2	Browse and DOWnload	115
B.2.1	Browsing For Content	116
B.2.2	Selecting Content for Viewing	117
B.3	Push	118
B.4	Portal	118

<b>ANNEX C CAPABILITY CODE SIGNALING EXAMPLE</b>	<b>120</b>
C.1 Scope	120
C.2 European Travel Destination NRT Service Example	120
<b>ANNEX D “BROWSER PROFILE A” SPECIFICATION</b>	<b>122</b>
D.1 Scope	122
D.2 Browser Profile A	122
D.2.1 CE-HTML	122
D.2.2 User Interface Profile	124
D.2.3 Optional Elements	124
D.2.4 Summary	125
<b>ANNEX E DTS-HD FILE STRUCTURE</b>	<b>127</b>
E.1 Introduction	127
E.2 Chunks	127
E.2.1 Chunk Parsing	129
E.2.2 Chunk Order and Navigation	129
E.2.3 Chunk Notation	130
E.2.4 DTSHDHDR	130
E.2.5 FILEINFO	132
E.2.6 CORESSMD	133
E.2.7 EXTSS_MD	134
E.2.8 AUPR-HDR	135
E.2.9 AUPRINFO	136
E.2.10 NAVI-TBL	137
E.2.11 BITSHVTB	137
E.2.12 STRMDATA	137
E.2.13 TIMECODE	138
E.2.14 BUILDVER	138
E.2.15 BLACKOUT	139
E.2.16 BRANCHPT	139
<b>ANNEX F AC-3 AND E-AC-3 FILE FORMATS</b>	<b>140</b>
F.1 Introduction	140
F.2 Specification	140
F.2.1 dataframe_type_0x0B	141
F.2.2 dataframe_type_0x77	141

## Index of Tables and Figures

<b>Table 5.1</b> Service ID Descriptor Syntax	25
<b>Table 5.2</b> Extension Structure	31
<b>Table 5.3</b> “HTTP Entity Header” ExtensionBody	32

---

<b>Table 5.4</b> “Entry” ExtensionBody	33
<b>Table 5.5</b> Filename Extensions and Content-Type Strings	35
<b>Table 6.1</b> Service-Level Descriptors in the Service Map Table	44
<b>Table 6.2</b> Component-Level Descriptors in the Service Map Table	45
<b>Table 6.3</b> Bit Stream Syntax for the Non-Real-Time Information Table	47
<b>Table 6.4</b> Content-Level Descriptors in the NRT-IT	52
<b>Table 6.5</b> Bit Stream Syntax for the Text Fragment Table	53
<b>Table 6.6</b> Syntax of Purchase Item Table	56
<b>Table 6.7</b> Syntax of Purchase Terms and Channels Table	60
<b>Table 7.1</b> Service Fragment	69
<b>Table 7.2</b> SMT-Related Private Extensions	71
<b>Table 7.3</b> Content Defaults	73
<b>Table 7.4</b> Associated Services	73
<b>Table 7.5</b> Schedule Fragment	74
<b>Table 7.6</b> Distribution Window	75
<b>Table 7.7</b> Presentation Window	76
<b>Table 7.8</b> Content Fragment	77
<b>Table 7.9</b> Content-Level Private Extensions	79
<b>Table 7.10</b> PurchaseItem Fragment	82
<b>Table 7.11</b> PurchaseData Fragment	83
<b>Table 8.1</b> Bit Stream Syntax for the Protocol Version Descriptor	84
<b>Table 8.2</b> Protocol Identifier	85
<b>Table 8.3</b> Protocol Version for protocol_identifier = 0x02 (IP Subnet)	85
<b>Table 8.4</b> Protocol Version for protocol_identifier = 0x03 (NRT)	86
<b>Table 8.5</b> Bit Stream Syntax for the NRT Service Descriptor	86
<b>Table 8.6</b> NRT Service Category	87
<b>Table 8.7</b> Capabilities Descriptor Syntax	88
<b>Table 8.8</b> Capability Categories and Registries	91
<b>Table 8.9</b> Bit Stream Syntax for the Icon Descriptor	92
<b>Table 8.10</b> Bit Stream Syntax for Component Data for FLUTE File Delivery (Type 38) as Modified For NRT	94
<b>Table 8.11</b> Bit Stream Syntax for the Time Slot Descriptor	95
<b>Table 8.12</b> Time Slot Types and Parameters	96
<b>Table 8.13</b> Bit Stream Syntax for the Internet Location Descriptor	97
<b>Table 8.14</b> Bit Stream Syntax for the Associated Service Descriptor	97
<b>Table 9.1</b> Bit Stream Syntax for the Receiver Targeting Descriptor	99
<b>Table 9.2</b> Targeting Criterion Type Codes	99
<b>Table 9.3</b> Bit Stream Syntax for the Targeting Criterion Table	104

<b>Table A.1</b> Capability Codes	108
<b>Table B.1</b> Typical Expected Content Types and Characteristics of NRT Usage Models	116
<b>Table C.1</b> Example Service Description	120
<b>Table C.2</b> Example Content Description	121
<b>Table C.3</b> Receiver Behavior	121
<b>Table D.1</b> Required and Optional Functionality for BPACR (Informative)	126
<b>Table E.1</b> List of Defined Chunks	127
<b>Table E.2</b> DTS-HD File Organization	130
<b>Table E.3</b> Time_Code Data	130
<b>Table E.4</b> Reference Clock Period	130
<b>Table E.5</b> TC_Frame_Rate Code	131
<b>Table E.6</b> Bitw_Stream_Metadata Bit Fields Syntax	132
<b>Table E.7</b> FILEINFO Metadata	132
<b>Table E.8</b> Core Sub-Stream Metadata	133
<b>Table E.9</b> Loudspeaker Masks	133
<b>Table E.10</b> Extension Sub-Stream Metadata	134
<b>Table E.11</b> Audio Presentation Header Metadata	135
<b>Table E.12</b> Bitw_Aupres_Metadata Bit Fields Syntax	136
<b>Table E.13</b> Audio Presentation Information Text	136
<b>Table E.14</b> Navigation Metadata	137
<b>Table E.15</b> Bit Shaving Metadata	137
<b>Table E.16</b> DTS-HD Encoded Stream Data	138
<b>Table E.17</b> DTS-HD Timecode Data	138
<b>Table E.18</b> DTS-HD BuildVer Data	138
<b>Table E.19</b> DTS-HD Encoded Blackout Data	139
<b>Table E.20</b> Branch Point Metadata	139
<b>Table F.1</b> AC-3 and E-AC-3 File Structure	141
<b>Table F.2</b> Dataframe Type 0x0B	141
<b>Table F.3</b> Dataframe Type 0x77	142
<b>Figure 4.1</b> Signaling of IP Subnet carrying NRT services for Fixed Broadcast.	20
<b>Figure 4.2</b> NRT services in the IP transport.	21
<b>Figure 7.1</b> ATSC-M/H Hierarchical Signaling Architecture.	65
<b>Figure 8.1</b> Parameters in Time Slot Descriptor – Example.	96
<b>Figure B.1</b> Example content selection UI.	117
<b>Figure B.2</b> Example Push service subscription screen.	118
<b>Figure B.3</b> Portal page example.	119
<b>Figure D.1</b> XHTML browser block diagram.	123

---

# ***ATSC Candidate Standard:*** **Non-Real-Time Content Delivery**

## **1. SCOPE**

This Standard describes the ATSC Non-Real-Time Content Delivery system, hereafter referred to as the ATSC NRT system or simply NRT. The NRT system provides support for delivery of content in advance of use (i.e., not streaming content). These ATSC-NRT services are carried in DTV broadcast multiplexes. The presence of these services do not preclude or prevent operation of current ATSC services in the same RF channel or have any adverse impact on legacy receiving equipment.

This Standard was prepared by the Advanced Television Systems Committee (ATSC) Technology and Standards Group (TSG) Specialist Group on Data Broadcast. It was approved by TSG as a Candidate Standard on 20 October 2010 and as a Proposed Standard on [date], and finally by the full ATSC membership of the ATSC on [date].

### **1.1 Introduction and Background**

Consumer expectations about sources of entertainment and information are undergoing a dramatic transformation, including an increasing desire for “everything-on-demand”. At the same time, technology is rapidly changing to enable new consumption and distribution models—significant amounts of storage capacity are appearing in receiving devices, personal media players have become commonplace and inter-device connectivity has become practical. These factors combine to allow a shift from linear TV viewing to on-demand consumption of content. One of the main enablers of this shift is the capability for Non-Real-Time delivery of content—content that is delivered in advance of its use and stored in the receiving device.

The NRT content can include both “traditional” TV fare (video/audio entertainment programming, news, weather, sports, etc.), information that is not now part of traditional TV fare or that is presented in a customized and non-traditional way as well as information not aimed at the TV at all (including content targeted to PCs, handheld media players or even commercial platforms).

Typical applications for NRT services include:

- Push VOD (content ranging from short-form video clips to feature length movies)
- News, information and weather services
- Personalized TV channels
- Music distribution
- Reference information on a wide range of topics

Delivery of Non-Real-Time services allows broadcasters to continue to capitalize on a unique advantage—the efficient delivery of localized content wirelessly to devices. The development of complete end-to-end standards to enable NRT service delivery is a critical part of the future of broadcasting.

## 1.2 Organization

This document is organized as follows:

- **Section 1** – Outlines the scope of this document and provides a general introduction
- **Section 2** – Lists references and applicable documents
- **Section 3** – Provides a definition of terms, acronyms, and abbreviations for this document
- **Section 4** – System overview
- **Section 5** – Content delivery specifications
- **Section 6** – Signaling and announcements for fixed NRT broadcasts (normative)
- **Section 7** – Signaling and announcements for mobile NRT broadcasts (normative)
- **Section 8** – Basic descriptors
- **Section 9** – Receiver targeting
- **Section 10** – Interaction channel
- **Annex A** – Capability code details
- **Annex B** – NRT service categories
- **Annex C** – Capability code signaling examples
- **Annex D** – Specifications of “Browser Profile A”
- **Annex E** – DTS-HD file structure
- **Annex F** – AC-3 and E-AC-3 file formats

## 2. REFERENCES

At the time of publication, the editions indicated were valid. All referenced documents are subject to revision, and users of this Standard are encouraged to investigate the possibility of applying the most recent edition of the referenced document.

### 2.1 Normative References

The following documents, in whole or in part, as referenced in this document, contain specific provisions that are to be followed strictly in order to implement a provision of this Standard.

- [1] ATSC: “Digital Audio Compression Standard (AC-3, E-AC-3),” Document A/52:2010, Advanced Television Systems Committee, Washington, D.C., 22 November 2010.
- [2] ATSC: “ATSC Data Broadcast Standard (including Amendment 1 and Corrigendum 1 and Corrigendum 2),” Document A/90, Advanced Television Systems Committee, Washington, D.C., 26 July 2000 (Amendment 1 dated 14 May 2002; Corrigendum 1 and 2 dated 1 April 2002).
- [3] ATSC: “ATSC Digital Television Standard, Part 3 – Service Multiplex and Transport Subsystem Characteristics,” Document A/53 Part 3:2009, Advanced Television Systems Committee, Washington, D.C., 7 August 2009.
- [4] ATSC: “ATSC Digital Television Standard, Part 4 – MPEG-2 Video System Characteristics,” Document A/53 Part 4:2009, Advanced Television Systems Committee, Washington, D.C., 7 August 2009.
- [5] ATSC: “ATSC Digital Television Standard, Part 5 – AC-3 Audio System Characteristics,” Document A/53, Part 5:2010, Advanced Television Systems Committee, Washington, D.C., 6 July 2010.

- 
- [6] ATSC: "ATSC Interaction Channel Protocols," Document A/96, Advanced Television Systems Committee, Washington, D.C., 3 February 2004.
  - [7] ATSC: "ATSC-Mobile DTV Standard, Part 3 – Service Multiplex and Transport Subsystem Characteristics," Document A/153 Part 3:2009, Advanced Television Systems Committee, Washington, D.C., 15 October 2009.
  - [8] ATSC: "ATSC-Mobile DTV Standard, Part 4 – Announcement" Document A/153 Part 4:2009, Advanced Television Systems Committee, Washington, D.C., 15 October 2009.
  - [9] ATSC: "ATSC-Mobile DTV Standard, Part 7 – AVC and SVC Video System Characteristics," Document A/153 Part 7:2009, Advanced Television Systems Committee, Washington, D.C., 15 October 2009.
  - [10] ATSC: "ATSC-Mobile DTV Standard, Part 8 – HE AAC Audio System Characteristics," Document A/153 Part 8:2009, Advanced Television Systems Committee, Washington, D.C., 15 October 2009.
  - [11] ATSC: "Content Identification and Labeling for ATSC Transport," Document A/57B, Advanced Television Systems Committee, Washington, D.C., 26 May 2008.
  - [12] ATSC: "DTV Application Software Environment Level 1 (DASE-1) Part 1: Introduction, Architecture, and Common Facilities," Doc. A/100-1, Advanced Television Systems Committee, Washington, D.C., 9 March 2003.
  - [13] ATSC: "Program and System Information Protocol for Terrestrial Broadcast and Cable," Document A/65:2009, Advanced Television Systems Committee, Washington, D.C., 14 April 2009.
  - [14] ATSC: "Video System Characteristics of AVC in the ATSC Digital Television System," Document A/72 Part 1:2008, Advanced Television Systems Committee, Washington, D.C., 29 July 2008.
  - [15] CEA: "Digital Television (DTV) Closed Captioning," CEA-708-D, Consumer Electronics Association, Arlington, VA.
  - [16] CEA: "Web-based Protocol and Framework for Remote User Interface on UPnP™ Networks and the Internet (Web4CE)," CEA-2014-B, Consumer Electronics Association, Arlington, VA.
  - [17] DECE: "Common File Format & Media Formats Specification," Digital Entertainment Content Ecosystem (DECE) LLC, 2011. <http://uvvu.com/>
  - [18] ECMA: "ECMAScript Language Specification, 5th Edition," ECMA-262, December 2009.
  - [19] ETSI: "DTS Coherent Acoustics; Core and Extensions with Additional Profiles", TS 102 114 v1.3.1, August 2011.
  - [20] IEEE: "Use of the International Systems of Units (SI): The Modern Metric System", Doc. IEEE/ASTM SI 10-2002, Institute of Electrical and Electronics Engineers, New York, N.Y., 2002.
  - [21] IETF: "Asynchronous Layered Coding (ALC) Protocol Instantiation," RFC 5775, Internet Engineering Task Force, Reston, VA, April 2010.
  - [22] IETF: "DEFLATE Compressed Data Format Specification version 1.3," RFC 1951, Internet Engineering Task Force, Reston, VA, May 1996.
  - [23] IETF: "FLUTE – File Delivery over Unidirectional Transport," RFC 3926, Internet Engineering Task Force, Reston, VA, October 2004.
  - [24] IETF: "Host Extensions for IP Multicasting," RFC 1112, Internet Engineering Task Force, Reston, VA, August 1989.

- 
- [25] IETF: “Hypertext Transfer Protocol -- HTTP/1.1,” RFC 2616, Internet Engineering Task Force, Reston, VA, June 1999.
  - [26] IETF: “Internationalized Resource Identifiers (IRIs),” RFC 3987, Internet Engineering Task Force, Reston, VA, January 2005.
  - [27] IETF: “Layered Coding Transport (LCT) Building Block,” RFC 5651, Internet Engineering Task Force, Reston, VA, October 2009.
  - [28] IETF: “MIME Type Registration for MPEG-4,” RFC 4337, Internet Engineering Task Force, Reston, VA, March 2006.
  - [29] IETF: “Multipurpose Internet Mail Extensions (MIME) Part One: Format of Internet Message Bodies”, RFC 2045, Internet Engineering Task Force, Reston, VA, November 1996.
  - [30] IETF: “Multipurpose Internet Mail Extensions (MIME) Part Two: Media Types,” RFC 2046, Internet Engineering Task Force, Reston, VA, November 1996.
  - [31] IETF: “PNG (Portable Network Graphics) Specification Version 1.0,” RFC 2083, Internet Engineering Task Force, Reston, VA, March 1997.
  - [32] IETF: “Real-time Transport Protocol (RTP) Payload Format for Enhanced AC-3 (E-AC-3) Audio,” RFC 4598, Internet Engineering Task Force, Reston, VA, July 2006.
  - [33] IETF: “RTP Payload Format for AC-3 Audio,” RFC 4184, Internet Engineering Task Force, Reston, VA, October 2005.
  - [34] IETF: “Scripting Media Types,” RFC 4329, Internet Engineering Task Force, Reston, VA, April 2006.
  - [35] IETF: “SDP: Session Description Protocol,” RFC 4566, Internet Engineering Task Force, Reston, VA, July 2006.
  - [36] IETF: “The Atom Syndication Format,” RFC 4287, Internet Engineering Task Force, Reston, VA, December 2005.
  - [37] IETF: “The audio/mpeg Media Type,” RFC 3003, Internet Engineering Task Force, Reston, VA, November 2000.
  - [38] IETF: “The ‘text/html’ Media Type,” RFC 2854, Internet Engineering Task Force, Reston, VA, June 2000.
  - [39] IETF: “Uniform Resource Identifier (URI): Generic Syntax,” RFC 3986, Internet Engineering Task Force, Reston, VA, January 2005.
  - [40] IETF: “Uniform Resource Identifiers (URI): Generic Syntax,” RFC 2396, Internet Engineering Task Force, Reston, VA, August 1998.
  - [41] IETF: “UTF-8, a transformation format of ISO 10646, F. Yergeau,” Doc. RFC 3629. Internet Engineering Task Force, Reston, VA, November 2003.
  - [42] IETF: “Basic Forward Error Correction (FEC) Schemes,” RFC 5445, Internet Engineering Task Force, Reston, VA, March 2009.
  - [43] IETF: “Raptor Forward Error Correction Scheme for Object Delivery,” RFC 5053, Internet Engineering Task Force, Reston, VA, October 2007.
  - [44] ISO/IEC: ISO/IEC 29500-2:2008, “Information technology – Document description and processing languages – Office Open XML File Formats – Part 2: Open Packaging Conventions.”
  - [45] ISO: “Codes for the representation of currencies and funds,” ISO 4217:2008, International Organization for Standardization, Geneva, July 2008.
  - [46] ISO: “Information technology – Coding of audio-visual objects – Part 3: Audio,” ISO/IEC 14496-3:2009, August 2009.

- [47] ISO: “Information technology – Computer graphics and image processing – Portable Network Graphics (PNG): Functional specification,” ISO/IEC 15948:2004, March 2004.
- [48] ISO: “Information technology – Document description and processing languages – Office Open XML File Formats – Part 1: Fundamentals and Markup Language Reference,” ISO/IEC 25900-2, November 2008.
- [49] ISO: “ISO/IEC 11172-3 - Information technology -- Coding of moving pictures and associated audio for digital storage media at up to about 1,5 Mbit/s -- Part 3: Audio”
- [50] ISO: “ISO/IEC 13818-3, Information Technology – Generic coding of moving pictures and associated audio information – Part 3: Audio.”
- [51] ISO: “ISO/IEC 14496-12:2003, Information technology – Coding of audio-visual objects – Part 12: ISO Base Media File Format”
- [52] ISO: “ISO/IEC 14496-14:2003, Information technology – Coding of audio-visual objects – Part 14: MP4 file format.”
- [53] ISO: “ISO/IEC IS 13818-1:2007 (E), International Standard, Information technology – Generic coding of moving pictures and associated audio information: systems.”
- [54] OMA: “File and Stream Distribution for Mobile Broadcast Services,” document OMA-TS-BCAST\_Distribution-V1\_0-20090212-A, Open Mobile Alliance, 12 February 2009.
- [55] OMA: “Mobile Location Protocol (MLP),” Candidate Version 3.1, document OMA-LIF-MLP-V3\_1-20040316-C, Open Mobile Alliance, 16 March 2004.
- [56] OMA: “Service Guide for Mobile Broadcast Services,” Version 1.0, document OMA-TS-BCAST\_Service\_Guide-V1\_0-20090212-A, Open Mobile Alliance, 12 February 2009.
- [57] W3C: “HTML 4.01 Specification,” REC-html401-19991224, 24 December 1999.
- [58] W3C: “XHTML 1.0, The Extensible HyperText Markup Language (Second Edition),” World Wide Web Consortium, 26 January 2000, revised 1 August 2002, <http://www.w3.org/TR/2002/REC-xhtml1-20020801/>

## 2.2 Informative References

The following documents contain information that may be helpful in applying this Standard.

- [59] ATSC: “ATSC-Mobile DTV Standard, Part 6 – Service Protection,” Document A/153 Part 6:2009, Advanced Television Systems Committee, Washington, D.C., 15 October 2009.
- [60] ATSC: “Conditional Access System for Terrestrial Broadcast, Revision A, with Amendment No. 1,” Document A/70A, Advanced Television Systems Committee, Washington, D.C., 22 July 2004 (Amendment No. 1 dated 11 September 2006).
- [61] ATSC: “Delivery of IP Multicast Sessions over ATSC Data Broadcast,” Document A/92, Advanced Television Systems Committee, Washington, D.C., 31 January 2002.
- [62] ETSI: TS 102 472 v1.3.1, “Digital Video Broadcasting (DVB); IP Datacast over DVB-H: Content Delivery Protocols,” June 2009.
- [63] IANA: “Hypertext Transfer Protocol (HTTP) Parameters,” <http://www.iana.org/assignments/http-parameters>.
- [64] IANA: “MIME Media Types,” <http://www.iana.org/assignments/media-types>.
- [65] IANA: “Reliable Multicast Transport (RMT) FEC Encoding IDs and FEC Instance IDs,” <http://www.iana.org/assignments/rmt-fec-parameters>.
- [66] ID3.org: “ID3 tag version 2.3.0,” ID3.org, <http://www.id3.org>, February 1999.
- [67] IETF: “FLUTE – File Delivery over Unidirectional Transport,” draft-ietf-rmt-flute-revised-11, Internet Engineering Task Force, Reston, VA, March 2010.
- [68] IETF: “The 'tag' URI Scheme,” RFC 4151, Internet Engineering Task Force, Reston, VA, October 2005.

- [69] Microsoft: “Portable encoding of audio-video objects: The Protected Interoperable File Format (PIFF),” John A. Bocharov, Quintin Burns, Florin Folta, Kilroy Hughes, Anil Murching, Larry Olson, Patrik Schnell, John Simmons, Microsoft Corporation, 2009. <http://go.microsoft.com/?linkid=9682897>.
- [70] NIMA: “Department of Defense World Geodetic System 1984,” NIMA TR8350.2, Third Edition, National Imagery and Mapping Agency, U.S. Department of Defense, January 2000.
- [71] SMPTE: SMPTE 428-3 “D-Cinema Distribution Master Audio Channel Mapping and Channel Labeling,” Society of Motion Picture and Television Engineers, White Plains, NY, September 2006.
- [72] SMPTE: SMPTE ST 2052-1-2010, “Timed Text Format (SMPTE-TT),” Society of Motion Picture and Television Engineers, White Plains, NY, December, 2010.

### 3. DEFINITION OF TERMS

With respect to definition of terms, abbreviations, and units, the practice of the Institute of Electrical and Electronics Engineers (IEEE) as outlined in the Institute’s published standards [20] shall be used. Where an abbreviation is not covered by IEEE practice or industry practice differs from IEEE practice, the abbreviation in question will be described in Section 3.3 of this document.

#### 3.1 Compliance Notation

This section defines compliance terms for use by this document:

**shall** – This word indicates specific provisions that are to be followed strictly (no deviation is permitted).

**shall not** – This phrase indicates specific provisions that are absolutely prohibited.

**should** – This word indicates that a certain course of action is preferred but not necessarily required.

**should not** – This phrase means that a certain possibility or course of action is undesirable but not prohibited.

#### 3.2 Treatment of Syntactic Elements

This document contains symbolic references to syntactic elements used in the audio, video, and transport coding subsystems. These references are typographically distinguished by the use of a different font (e.g., `restricted`), may contain the underscore character (e.g., `sequence_end_code`) and may consist of character strings that are not English words (e.g., `dynrng`).

##### 3.2.1 Reserved Elements

One or more reserved bits, symbols, fields, or ranges of values (i.e., elements) may be present in this document. These are used primarily to enable adding new values to a syntactical structure without altering its syntax or causing a problem with backwards compatibility, but they also can be used for other reasons.

The ATSC default value for reserved bits is ‘1.’ There is no default value for other reserved elements. Use of reserved elements except as defined in ATSC Standards or by an industry standards setting body is not permitted. See individual element semantics for mandatory settings and any additional use constraints. As currently-reserved elements may be assigned values and meanings in future versions of this Standard, receiving devices built to this version are expected

to ignore all values appearing in currently-reserved elements to avoid possible future failure to function as intended.

### **3.3 Acronyms and Abbreviations**

The following acronyms and abbreviations are used within this specification.

**AAC** – Advanced Audio Coding

**ALC** – Asynchronous Layered Coding

**ATSC** – Advanced Television Systems Committee

**BPACR** – Browser Profile A-capable receiver

**bslbf** – bit serial, leftmost bit first

**CA** – Conditional Access

**CDP** – Content Delivery Protocol

**CEA** – Consumer Electronics Association

**CFF** – Common File Format

**CRS** – Coordinate Reference System

**DECE** – Digital Entertainment Content Ecosystem

**DSM-CC** – Digital Storage Media Command and Control

**DTV** – Digital Television

**DVB** – Digital Video Broadcast

**EIT** – Event Information Table

**ES** – Elementary Stream

**FCC** – Federal Communications Commission

**FDT** – File Delivery Table

**FEC** – Forward Error Correction

**FIC** – Fast Information Channel

**FLUTE** – File Delivery over Unidirectional Transport

**GB** – Gigabyte (1000<sup>3</sup> bytes)

**GIF** – Graphics Interchange Format

**GPS** – Global Positioning System

**HDTV** – High-Definition TV

**HE AAC** – High Efficiency Advanced Audio Coding

**HTML** – Hypertext Markup Language

**HTTP** – Hypertext Transfer Protocol

**IANA** – Internet Assigned Numbers Authority

**IEC** – International Electrotechnical Commission

**IETF** – Internet Engineering Task Force

**IP** – Internet Protocol

**IPTV** – Internet Protocol Television

**ISO** – International Organization for Standardization

**JPEG** – Joint Photographic Experts Group

**LCT** – Layered Coding Transport

**LLC/SNAP** – Logical Link Control/Sub-Network Access Protocol

**M/H** – Mobile/Handheld  
**MPEG** – Moving Picture Experts Group  
**MPEG-2** – Refers to ISO/IEC 13818 protocols  
**MTU** – Maximum Transmission Unit, defined as the maximum datagram size  
**NRT** – Non-Real-Time  
**NRT-IT** – Non-Real-Time Information Table  
**OMA** – Open Mobile Alliance  
**OMA BCAST** – OMA Mobile Broadcast Services Enabler Suite  
**OTI** – Object Transmission Information  
**PAT** – Program Association Table (MPEG-2)  
**PID** – Packet Identifier  
**PIT** – Purchase Item Table  
**PMT** – Program Map Table (MPEG-2)  
**PNG** – Portable Network Graphics  
**PTCT** – Purchase Terms and Channel Table  
**PSIP** – Program and System Information Protocol  
**PVD** – Protocol Version Descriptor  
**RFC** – Request for Comments (IETF)  
**RME** – Rich Media Environment  
**RT** – Real-time  
**RUI** – Remote User Interface  
**SDO** – Standards Developing Organization  
**SG** – Service Guide  
**SMT** – Service Map Table  
**SSC** – Service Signaling Channel  
**TFT** – Text Fragment Table  
**TOI** – Transport Object Identifier  
**TS** – Transport Stream  
**TSG** – Technology and Standards Group  
**TSI** – Transport Session Identifier  
**TVCT** – Terrestrial Virtual Channel Table  
**UDP** – User Datagram Protocol  
**uilsBf** – unsigned integer, least significant Byte first  
**uilsWBf** – unsigned integer, least significant Word and Byte first  
**uimsbf** – unsigned integer, most significant bit first  
**URI** – Uniform Resource Identifier  
**URL** – Uniform Resource Locator  
**UTC** – Coordinated Universal Time  
**VCT** – Virtual Channel Table  
**VOD** – Video On Demand  
**W3C** – World-Wide Web Consortium  
**XHTML** – eXtensible Hypertext Markup Language

## XML – eXtensible Markup Language

### 3.4 Terms

The following terms are used within this specification.

**Activation Symbol** – An on-screen graphical symbol that functions to signal the user that NRT content is available to be consumed.

**Browse and Download** – An NRT Service Category in which content is offered that can be downloaded and viewed at a later time.

**Content Delivery** – The announcement and signaling protocols associated with the delivery of content and metadata, including the protocols for the transport of the content essence itself.

**Content Item** – a set of one or more files that an NRT service provider intends to be treated as a single unit for presentation purposes.

**FLUTE file** – A file delivered over FLUTE [23] (see also [26]).

**Mobile DTV** – Refers to the ATSC standards described in A/153.

**Non-Real-Time** – Generally refers to content that is delivered in advance of its use and stored in the receiving device. May refer to content that is delivered faster than real-time, such that buffering is required in the receiving device.

**octet** – A unit of eight data bits.

**Portal** – An NRT Service Category that is intended to offer an experience similar to browsing the Internet using a web browser. Portal content is available for download at low latency (while the user waits).

**Push** – An NRT Service Category involving request-based content. For Push NRT services, receivers are expected to offer the user a choice whether or not to automatically update content associated with the service.

**reserved** – An element that is set aside for use by a future Standard.

**Service Category** – As used in the context of NRT services, refers to the intended consumption model for the NRT service; e.g. how the service provider expects NRT receivers to present the service to the user. The three Service Categories defined in the present Standard are described in Annex B.

### 3.5 Extensibility

This Standard describes a number of tables and data structures conveying metadata. The Standard is designed to be extensible via the following mechanisms:

**Table length extensions** – Future amendments to this Standard may include new fields at the ends of certain tables. Tables that may be extensible in this way include those in which the last byte of the field may be determined without use of the `section_length` field. Such an extension is a backwards compatible addition.

**Descriptor length extensions** – Future amendments to this Standard may include new fields at the ends of certain descriptors. Descriptors extensible in this way include those in which the last byte of the last currently defined field may be determined without the use of the `descriptor_length` field.

**New descriptor types** – Future amendments to this Standard may define new types of descriptors not recognized or supported by existing receiving devices. A descriptor whose `descriptor_tag` identifies a type not recognized by a particular receiver is expected to be ignored. Descriptors can be included in certain specified places within tables, subject to

certain restrictions. Descriptors may be used to extend data represented as fixed fields within the tables. They make the protocol very flexible since they can be included only as needed. New descriptor types can be standardized and included without affecting receivers that have not been designed to recognize and process the new types.

### 3.5.1 Descriptor Processing Considerations

The descriptors used in “descriptor loops” in this Standard have the format: type (`descriptor_tag`), length (`descriptor_length`), and data, as specified in the MPEG-2 Systems Standard [53]. See for example the last field in Table 6.3, indicated as “descriptor()”.

These “descriptor loops” indicate that zero, one or more descriptors are carried in that position in the stream. For many descriptor loops, certain descriptors are required and others are optional.

However, these requirements specify descriptors which are required to or optionally may be carried in a particular descriptor loop. There are a large number of reserved and user-defined descriptor types which may be in private usage, or may be standardized in later versions of a standard.

#### 3.5.1.1 Processing Descriptor Loops

Descriptor loops are collections of descriptors, and each descriptor must be at least partially processed in order to parse the transport stream. Receivers are expected to parse the `descriptor_tag` and `descriptor_length`, and subsequently either process the content of the descriptor or discard `descriptor_length` bytes from the transport stream and proceed with the next entry in the descriptor loop (if any).

#### 3.5.1.2 Treatment of Descriptor Length

The length of each descriptor in a descriptor loop is *exclusively* described by the `descriptor_length` field. There are certain descriptors that have multiple allowable lengths. There are descriptors with `descriptor_length` of zero.

Receivers are expected to be able to parse (or skip, as appropriate) descriptors of zero length. Receivers are expected to be able to parse (or skip, as appropriate) descriptors with varying length. Receivers are expected to be able to parse (or skip, as appropriate) descriptors with non-zero, but unexpected length (where length is either larger or smaller than expected).

#### 3.5.1.3 Treatment of Unrecognized Descriptor Types

For the reason discussed above, descriptors have a common header (`descriptor_type` and `descriptor_length`) which devices use to identify descriptors and process them (if they are a known type).

However, unrecognized descriptors (either unrecognized in the location found or otherwise) *are not errors*. Emission, processing and reception devices are expected to silently ignore descriptors that they do not process.

#### 3.5.1.4 Descriptor Order within a Descriptor Loop

The collection of descriptors carried in a descriptor loop is an unordered set. *No information is provided* by the fact that a particular descriptor is before or after another within a descriptor loop.

## 3.6 XML Schema and Namespace

A number of new XML elements are defined in this Standard. These elements are designed to be embedded in XML documents of two types:

- Service Guide fragments, consisting of elements defined by the OMA BCAST Service Guide [56] schema.
- FLUTE FDT instances, consisting of elements defined by the modified FLUTE FDT schema specified for OMA BCAST File Distribution [54].

Taken together, these new XML elements shall constitute the XML schema for this Standard. The namespace for this schema shall be

<http://www.atsc.org/XMLSchemas/nrt/2010/1>

indicating that this is major version 1 of the schema.

The “schema” element of the XML schema shall have a “version” attribute set to the value 1.0, indicating that the minor version number of the schema is 0.

In order to provide flexibility for future changes in the schema, decoders of XML documents with the namespace defined above should follow the “must ignore” rule. That is, they should ignore any elements or attributes they do not recognize, rather than treating them as errors.

It is recommended that the abbreviation “nrt” be used as the namespace prefix for any of the elements of this schema that appear in an XML document. For the initial release of this Standard the binding of this prefix to the namespace can be declared by including the following attribute in the “schema” element of the document.

```
xmlns:nrt="http://www.atsc.org/XMLSchemas/nrt/2010/1"
```

Two separate XML schema documents together provide the element definitions for this version of the standard:

- The document named “TBD” which can be found at TBD provides the SG extensions
- The document named “TBD” which can be found at TBD provides the FDT extensions

In the event of any discrepancy between the XML schema definitions that appear in this document and those that appear in the XML schema document, those in the XML schema documents are authoritative and take precedence.

## 4. SYSTEM OVERVIEW

### 4.1 System Architecture

This Standard specifies standardized signaling, announcement, and transport of NRT essence for both fixed-broadcast and Mobile DTV applications.

#### 4.1.1 Fixed-Broadcast NRT System Architecture

Non-Real-Time services for fixed broadcast are delivered within IP subnets; the particular IP subnets associated with a given virtual channel are identified by references in the Terrestrial Virtual Channel Table (TVCT) and associated PAT/PMT tables. This standard builds on methods defined in ATSC data broadcast standards, including A/90 [2] and A/92 [61], which define the carriage of IP packets in the MPEG-2 Transport Stream using the DSM-CC Addressable Section format.

Figure 4.1 illustrates an example NRT service, showing how parameters in the TVCT link to the PAT and PMT, how program elements identified in the PMT carry DSM-CC Addressable Sections, and how the services in each program element are signaled.

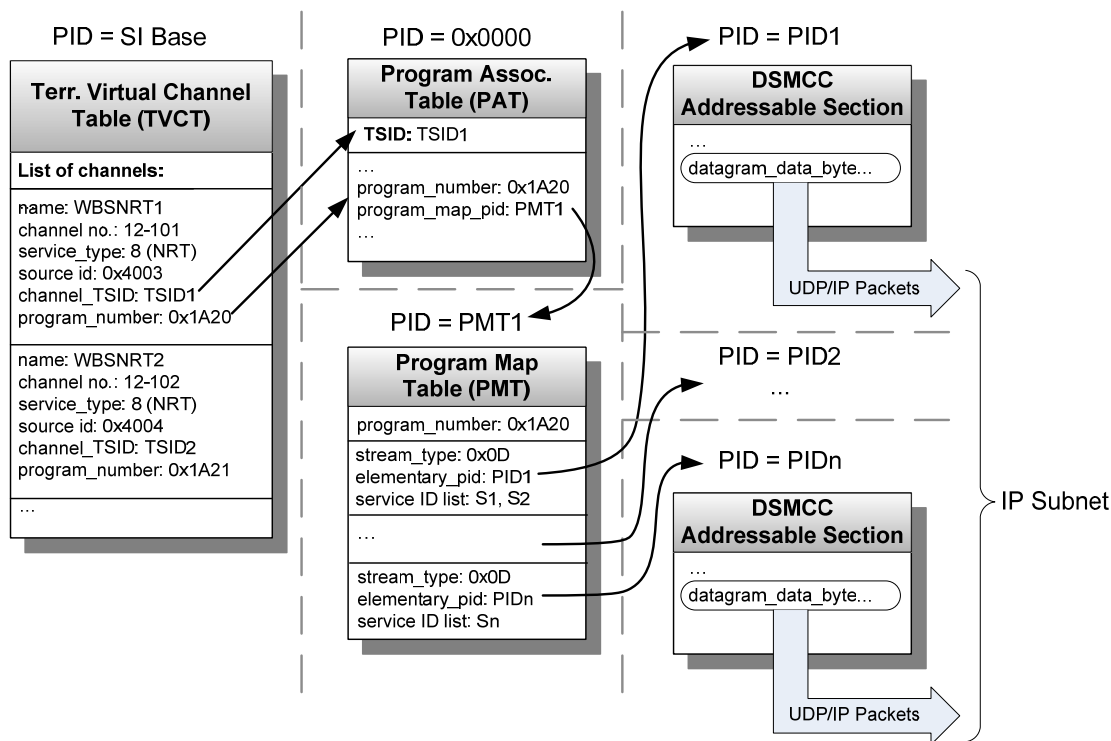

**Figure 4.1** Signaling of IP Subnet carrying NRT services for Fixed Broadcast.

The example shown in Figure 4.1 illustrates a “standalone” NRT service, which is a service consisting exclusively of NRT-delivered content. This Standard also allows for the delivery of NRT content as “adjunct” to other services, although consumption models and expected receiver behavior for adjunct services is not described.

As shown in the example in Figure 4.1, one virtual channel listed in the TVCT announces a channel associated with Service Type value of 0x08; value 0x08 for service\_type is defined in this Standard to signify a standalone NRT service.

As with all virtual channels, the channel\_TSID value identifies the Transport Stream multiplex that will carry the associated services. In the example, the TSID value corresponds to the same Transport Stream that carries the TVCT. The virtual channel data provides the program\_number associated with the channel. Parsing the Program Association Table produces a match on this program\_number value, which yields the program\_map\_pid value. Acquiring and parsing the PMT yields one or more program elements comprising the MPEG-2 program.

In accordance with A/90 [2], the program elements in the PMT are of stream\_type value 0x0D, corresponding to “ISO/IEC 13818-6 type D” streams. The TS packets referenced by the PID values indicated in the PMT in turn carry DSM-CC Addressable Section structures, which encapsulate IP packets.

As shown in Figure 4.1, the PMT may indicate more than one program element of stream\_type value 0x0D; e.g. IP packets for different NRT services in a single virtual channel may be

delivered in TS packets of multiple PID values. All IP packets delivered in all DSM-CC Addressable Sections referenced in the PMT are aggregated together to form one IP subnet.

One specific IP address and port number, 224.0.23.60:4937, is recognized as the Service Signaling Channel, SSC (registered by ATSC with the Internet Assigned Numbers Authority for A/153).

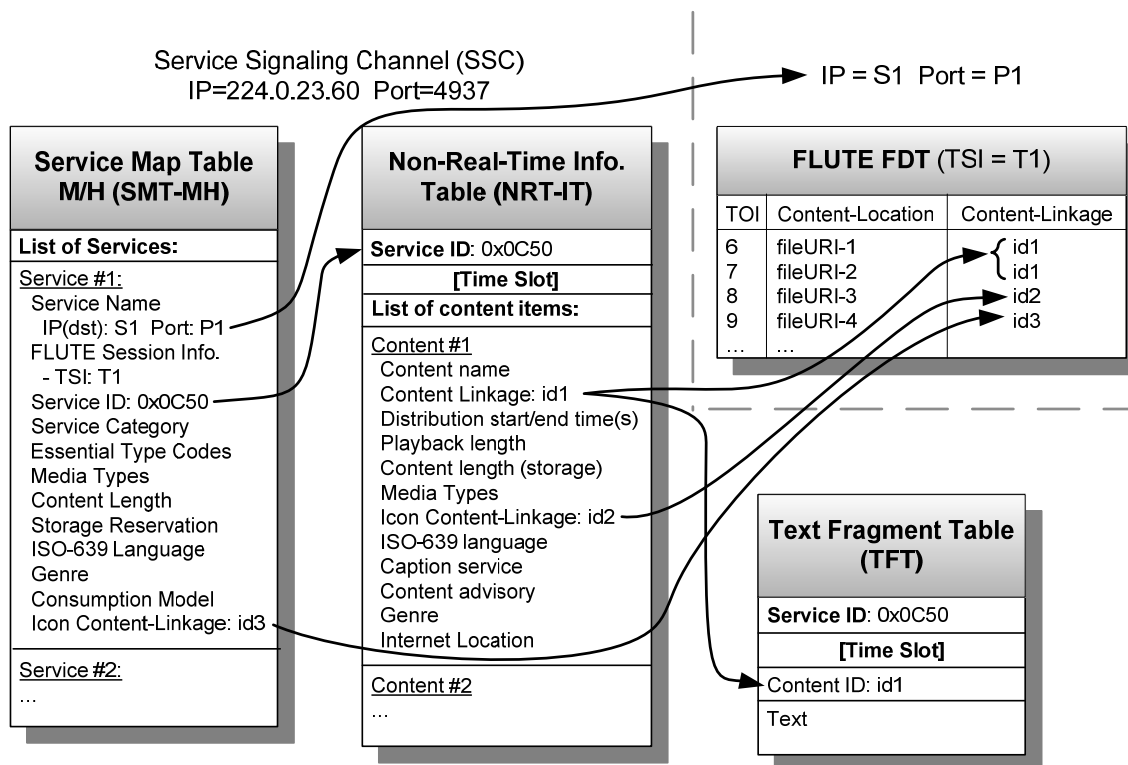

**Figure 4.2** NRT services in the IP transport.

Figure 4.2 illustrates three tables carried in the SSC: the Service Map Table (SMT), the Non-Real-Time Information Table (NRT-IT), and the Text Fragment Table (TFT).

The function of the SMT is to describe one or more services associated with this virtual channel. Information describing each service includes:

- The descriptive name of the service, to be used in user interactions
- Parameters of one or more FLUTE sessions where files associated with the service may be found
- A “Service ID” value used as a linkage to the NRT-IT, and to establish the virtual channel number to be associated with the service
- A Service Category, which is set for 0x0E to indicate this is an NRT service
- A “consumption model” for the service
- A description of the decoding and file format resources necessary in the receiver for it to be able to present a meaningful presentation of the service

- Optional descriptive metadata including language, genre, minimum recommended storage required to handle the service, and a pointer to a graphical icon descriptive of the service

As mentioned, the SMT links to the NRT-IT through the `service_id` field. Each NRT service is associated with one or more content items, each of which consists of one or more files. The function of the NRT-IT is to provide descriptive metadata about the content item(s) that make up a given service. Information describing each content item includes:

- A descriptive title of the content
- An indication as to when the content item is scheduled to be available for download
- A description of file formats and/or codecs beyond those listed at the service level when needed in the receiver for it to be able to present a meaningful presentation of the content
- An optional reference to a graphical icon descriptive of the content
- Optional descriptive metadata including language, genre, storage requirements, number of audio channels, content advisory, caption service information
- An optional indication that the content may be retrieved via the Internet, and, if so, a URL

References to file content are made by 32-bit unsigned integer “content linkage” values. The receiver matches a `content_linkage` value in the NRT-IT with one or more files listed in the FLUTE File Delivery Table (FDT) to identify the content item to which the file(s) belong. In the example of Figure 4.2, content linkage value `id1` links to two files in the FDT. Icons at the service and content level are also linked to the FLUTE FDT using 32-bit linkage values, as shown in Figure 4.2.

The 32-bit content linkage value is also used to associate textual data with content items. Text blocks delivered in the Text Fragment Table are tied to content items using this method as well.

#### 4.1.1.1 Channel Numbers

While the major/minor channel number of this example channel is 12.101, receivers are expected *not* to use this number in any user interface functions. The reason is that for NRT there is not always a one-to-one relationship between a virtual channel and one “channel” or service as experienced by the user. The IP subnet referenced by one virtual channel may carry multiple NRT services, and each may be referenced by its own service ID.

On the IP transport side, major/minor channel numbers are signaled within the Service Map Table (SMT). In the example of Figure 4.2 the `service_id` value is 0x0C50. Receivers are expected to use the most-significant 8 bits of `service_id` as the major channel number, and the least-significant 8 bits as minor channel number. Accordingly in this case, they would associate the service with channel 12.80.

#### 4.1.2 Mobile Broadcast NRT System Architecture

Non-Real-Time services for mobile broadcast are delivered within IP datagrams, carried as specified in the ATSC Mobile DTV Standard (A/153 Part 3 [7]).

The Signaling subsystem provides the information necessary for a receiver to acquire and present the content of NRT services. The signaling of ATSC mobile NRT services is based on the system used for signaling M/H services in general, namely the FIC/SMT hierarchy (Fast Information Channel and Service Map Table). The use of the SMT for signaling ATSC mobile NRT services is nearly identical to its use for signaling ATSC fixed NRT services. However, in

the mobile case, a broadcaster also has the possibility of expressing some of the service-level information in the Announcement data used for the content guide.

The Announcement subsystem is used to announce information regarding the NRT services and content available on a given ATSC system. The information available through the Announcement subsystem provides receivers with a robust description of the available services and content, as well as the schedule information and access parameters necessary to receive the services and content, including purchasing information.

Mobile NRT services and content are announced through the ATSC-M/H Announcement subsystem using a service guide, as described in A/153 Part 4 [8], with constraints and extensions for NRT services as specified in this Standard. Mobile NRT services and content may be described in an instance of the service guide which also describes other services available via ATSC Mobile DTV (e.g., linear audio and video) or they may be described in an entirely separate service guide instance.

The FLUTE extensions used for ATSC Mobile DTV NRT services are exactly the same as those used for ATSC fixed NRT services.

## 4.2 Content Item Concept

A content item is a set of one or more files that an NRT service provider intends to be treated as a single unit for presentation purposes. One can think of a content item as the logical unit of delivery of NRT content. (This definition is semantically similar to the definition of “content item” in the DVB IPTV CDS specification [62], which is: “an editorially coherent grouping of one or more audiovisual or generic data files which are intended to be consumed in conjunction with each other.”)

For broadcasts to mobile receivers, content items are announced and described in Content elements of the OMA BCAST Service Guide (SG). For broadcasts to fixed receivers, content items are announced and described in `content_item` entries in the NRT Information Table (NRT-IT).

The files belonging to a content item are delivered in one or more FLUTE file delivery sessions that are components of the service with which the content item is associated.

The linkages from content items to the files that belong to them are achieved by matching the values of Content-Linkage elements defined for the files in the FLUTE FDT with values of ContentLinkage elements in the Content elements of the SG in the mobile case, and with the value of `content_linkage` field elements of `content_item` entries of the NRT-IT in the fixed case.

A Content-Linkage element for a file in the FLUTE FDT can have a Boolean “entry” attribute that identifies the file as an entry point (or launch point) of the content item identified by the Content-Linkage value; i.e., when a content item is selected by a viewer for presentation, the receiver is expected to present initially the file of the content item that has the entry point designation.

Note: This Standard does not specifically prohibit a content item from having more than one entry point, but the behavior of receivers is not predictable when a content item has more than one entry point.

## 4.3 Consumption Models

Each NRT service references one or more content items delivered on the multicast IP transport via the FLUTE file delivery protocol. In addition to information describing the service and the

content and how to acquire the files, this standard defines signaling to the receiver indicating how the broadcaster expects it to present the service to the user; e.g., what it should do with the files associated with a given service.

Three “consumption models” are defined in the current standard: “Browse and Download,” “Push,” and “Portal.” These are described in Annex B.

## 5. CONTENT DELIVERY SPECIFICATIONS

### 5.1 IP Delivery

#### 5.1.1 ATSC Fixed

Each Virtual Channel delivering NRT services shall be constructed as follows:

- The Program Association Table entry referenced by the `channel_TSID/program_number` in the VCT shall reference a Program Map Table section describing an MPEG-2 program containing one (or more) program element(s) of `stream_type 0x0D`.
- NRT services shall be delivered within an IP subnet of the virtual channel. Said IP subnet can be signaled in either of two ways:
  - If the IP subnet is to consist of the all the datagrams carried in all the program elements of `stream_type 0x0D` in the PMT section, then a Protocol Version Descriptor with `protocol_identifier` value `0x02` and major version number `0x01` shall appear in the `program_info` descriptor loop of the PMT.
  - If the IP subnet is to consist of only the datagrams in a subset of the program elements of `stream_type 0x0D`, that subset shall be identified by the presence of a Protocol Version Descriptor with `protocol_identifier` value `0x02` and major version number `0x01` in the descriptor loop following `ES_info_length` of each individual program element in the subset.

In either case the combination of the major version number and minor version number in the Protocol Version Descriptor or Descriptors identifies the protocol version of the IP subnet specification.

The following requirements apply to the program elements that are part of the IP subnet when the major protocol version of the IP subnet is “1” and the minor protocol version is “0”:

- The program elements identified as part of the IP subnet shall contain MPEG-2 transport stream packets carrying IP multicast packets encapsulated in DSM-CC addressable sections as specified in ATSC Standard A/90 [2] Section 8, with the additional constraints that the LLC/SNAP() structure shall not appear.
- The `deviceid` fields of each DSM-CC addressable section (`deviceid[47..40]` through `deviceid[7..0]`) shall be derived from the IP multicast address of the IP packet contained in the addressable section by applying the mapping of IP multicast addresses to Ethernet multicast addresses defined in Section 6.4 of RFC 1112 [24].
- The MTU (Maximum Transmission Unit, defined as the maximum datagram size) of the IP multicast datagrams carried in the DSM-CC addressable sections shall be 1500 bytes.
- The IP packets with multicast address 224.0.23.60 and UDP port 4937 shall constitute a Service Signaling Channel (SSC), which shall not contain any IP packets other than those containing table sections specified to go in such SSC by this ATSC NRT Standard or other ATSC Standards. Receivers are expected to gracefully ignore any tables found in

the SSC with unrecognized table\_id field or with a recognized table\_id but unrecognized major protocol version number for the table.

- Each table section in the SSC shall contain a table\_id field in the first byte of the section and a major/minor protocol version number for the table in the fourth byte of the section (where the most significant 4 bits of the protocol version field contain the major version number and the least significant 4 bits of the protocol version field contain the minor version number).
- The least-significant 8 bits of the program\_number shall be considered the subnet\_id for this IP subnet. The value of program\_number shall be set to ensure a unique value of subnet\_id is defined for each such IP subnet in the Transport Stream.

Each NRT service carried in this subnet shall be delivered in IP packets encapsulated within MPEG-2 transport stream packets having the same PID value (i.e., being in the same program element).

MPEG-2 TS packets with the same PID value (hereinafter referred to as a ‘program element’) may be used for multiple NRT services. For each program element in this IP subnet, the descriptor loop following the ES\_info\_length of the PMT shall contain a Service ID Descriptor, defined below, which shall list the service\_id values of all the services carried in that program element and indicate whether the Service Signaling Channel is contained in that program element.

**Table 5.1** Service ID Descriptor Syntax

Syntax	No. of Bits	Format
service_id_descriptor() {		
<b>descriptor_tag</b>	8	0xC2
<b>descriptor_length</b>	8	uimsbf
<b>service_count</b>	8	uimsbf
for (i=0; i<service_count; i++)		
<b>service_id</b>	16	bslbf
for (j=0; j< N; j++) {		
<b>reserved</b>	8	bslbf
}		
}		

The semantics of the fields in this descriptor are given below.

**descriptor\_tag** — This 8-bit unsigned integer shall have the value 0xC2, identifying this descriptor as a service\_id\_descriptor().

**descriptor\_length** — This 8-bit unsigned integer shall specify the length (in bytes) immediately following this field up to the end of this descriptor.

**service\_count** — This 8-bit unsigned integer shall indicate the number of services carried in the program element to which this descriptor is attached.

**service\_id** — This 16-bit unsigned integer shall be the service\_id of one of the services contained in the program element to which this descriptor is attached, or, in the case of service\_id value 0x0000, it shall indicate that the Service Signaling Channel (defined in section 6.1.4) is contained in the program element to which this descriptor is attached. (Note that under the service\_id allocation scheme mandated in Annex B of A/153 Part 3 [7] the service\_id value 0x0000 is reserved for ATSC use.)

### 5.1.2 ATSC Mobile

IP datagrams shall be carried in ATSC Mobile DTV per the specifications in A/153 Part 3 [7], Section 6.

## 5.2 FLUTE File Delivery

Non-Real-Time content files carried in an ATSC broadcast stream shall be delivered via the FLUTE protocol, in conformance with the FLUTE specifications in IETF RFC 3926 [23] (see also [26]), as extended in Section 5.3 of this Standard. This applies to broadcast streams targeted to fixed receivers per the ATSC DTV Standard [3] and to broadcast streams targeted to mobile receivers per the ATSC Mobile DTV Standard [7].

FLUTE is a protocol for delivery of arbitrary types of files over a unidirectional IP link. It uses the IETF ALC (Asynchronous Layered Coding) protocol, defined in IETF RFC 5775 [21], which in turn uses the IETF LCT (Layered Coding Transport) protocol, defined in IETF RFC 5651 [27].

The LCT protocol provides “Transport Session Identifier” (TSI) and “Transport Object Identifier” (TOI) fields in the LCT packet header to identify what transport session and transport object a packet coming from a single sender belongs to; i.e., the transport session an LCT packet belongs to is characterized by the IP source address and the TSI of the packet, and the transport object the packet belongs to is characterized by the IP source address, the TSI, and the TOI of the packet. LCT also provides a mechanism to define “header extensions” that can be used to add additional attributes for packets, and it defines a specific header extension EXT\_AUTH that can be used to carry information to authenticate the sender.

The primary “value added” of the ALC protocol is support for forward error correction (FEC). It defines an LCT header extension EXT\_FTI that can be used to carry FEC Object Transmission Information for the object the packet belongs to, and it adds an “FEC Payload ID” field immediately following the LCT header, which uniquely identifies the encoding symbol(s) that constitute the payload of the packet. The details on FEC for ATSC NRT transmitters and receivers are specified in Section 5.4.

The “value added” of the FLUTE protocol is the File Delivery Table (FDT), essentially a directory of the files carried in the session. The FDT is carried in the form of one or more “FDT Instance” packets, each of which contains an XML structure giving file properties for some subset of the files delivered in the session. There is no restriction on how many FDT Instances there are, or how the sets of files covered by the FDT Instances can overlap. The LCT TOI value 0 is reserved for FDT Instances, and FLUTE protocol defines an LCT header extension EXT\_FDT containing a 20-bit “FDT Instance ID” to uniquely identify the different FDT instances. It also defines an LCT header extension EXT\_CENC that can be used to identify the content encoding algorithm for an FDT Instance that is content encoded. (Content encoding of other files can be indicated in the FDT, so there is no need to use this header extension for other files.)

The fields in the LCT header shall conform to the following constraints:

- C = 0, indicating Congestion Control Information (CCI) field is 32 bits in length
- S = 0, O = 0, and H = 1, indicating both TSI and TOI fields are 16 bits in length, OR S = 1, O = 1, and H = 0, indicating both TSI and TOI fields are 32 bits in length
- T = 0, indicating the Sender Current Time field is not present
- R = 0, indicating the Expected Residual Time field is not present

- CCI = 0

The “A” field in an LCT header may be set to ‘1’ to indicate the last packet of the session.

The “B” field in an LCT header may be set to ‘1’ to indicate that no further packets will be transmitted for that object in the session (where an “object” is identified by the TOI; i.e., other versions of the file could be transmitted in the future, but no further instances of the current version will be transmitted).

The LCT header extension EXT\_TIME shall not be used.

The number of FLUTE sessions in a single service shall not exceed 8, the number of FLUTE channels in a single FLUTE session shall not exceed 8, and the total number of FLUTE channels in a single service shall not exceed 16.

It is strongly recommended that all of the FLUTE channels in each FLUTE session have the same destination IP address and have consecutively numbered UDP ports, so that they can be signaled with a single FLUTE component descriptor in the SMT.

### 5.3 FLUTE FDT Extensions for Linkage of Files to Content Items

A single NRT “content item” may consist of multiple files. Therefore, it is necessary to have some way to link the files delivered via FLUTE sessions to the content items. This section defines extensions to the XML schema of the FLUTE FDT to support such linkages. Section 5.12 on announcements for fixed NRT broadcasts and Section 7.2 on announcements for mobile NRT broadcasts define precisely how these extensions are used.

The FLUTE FDT Instances delivered in ATSC NRT broadcasts, both fixed and mobile, shall conform to the definition of the FDT-Instance element contained in the OMA BCAST Distribution document<sup>1</sup>, with the addition of the two elements described below:

---

```
<xs:element name="FDTContentLinkage" type="FDTContentLinkageType"/>

<xs:complexType name="FDTContentLinkageType">
  <xs:simpleContent>
    <xs:extension base="xs:unsignedInt">
      <xs:anyAttribute processContents="skip"/>
    </xs:extension>
  </xs:simpleContent>
</xs:complexType>

<xs:element name="FileContentLinkage" type="FileContentLinkageType"/>
```

---

<sup>1</sup> This includes the OMA BCAST [54] extension for the FullFDT attribute of the FDT-Instance element, which signals that the FDT instance describes all files currently being transmitted.

---

```

<xs:complexType name="FileContentLinkageType">
  <xs:simpleContent>
    <xs:extension base="xs:unsignedInt">
      <xs:attribute name="entry" type="xs:boolean" use="optional"
        default="false"/>
      <xs:anyAttribute processContents="skip"/>
    </xs:extension>
  </xs:simpleContent>
</xs:complexType>
:

```

---

These elements are part of the XML schema for this ATSC NRT Standard, with namespace as defined in Section 3.6. These elements are defined in the XML “FDT” schema file which accompanies this standard, and that definition shall take precedence over the description provided here in the event of any difference.

One or more instances of the FDTContentLinkage elements may appear as instantiations of the element

---

```

<xs:any namespace="##other" processContents="skip" minOccurs="0"
maxOccurs="unbounded"/>

```

---

that appears in the type definition of the FDT-InstanceType. When they do appear there, they shall specify the default content linkage tag(s) for all files in the FDT Instance.

One or more instances of the FileContentLinkage elements may appear as instantiations of the element

---

```

<xs:any namespace="##other" processContents="skip" minOccurs="0"
maxOccurs="unbounded"/>

```

---

that appears in the definition of the FileType. When they do appear there, they shall specify the content linkage tag(s) for that specific file.

If one or more FDTContentLinkage elements are present for an FDT-Instance, and one or more FileContentLinkage elements are present for a File in that FDT-Instance, the tag value(s) specified by the FileContentLinkage element(s) shall override all tag value(s) specified by the FDTContentLinkage element(s).

The presence of an “entry” attribute of the FileContentLinkage element of a File with value “true” shall indicate that the File is an entry point for the content item identified by the content linkage tag. The absence of this attribute or the presence of this attribute with value “false” shall indicate that the File is not an entry point for that content item.

When a content item is selected by a viewer for presentation, and the content item consists of multiple files, it is expected that an entry point of the file will be launched (rendered by the appropriate application for the data type of that file). If no entry point is specified for such a content item, or if multiple entry points are specified for such a content item, then the expected behavior of the receiver is unspecified.

## 5.4 Forward Error Correction (FEC)

### 5.4.1 Symbol Encoding Algorithm

The FLUTE packets either shall be formatted using the “Raptor FEC scheme” RFC 5053 [43] (FEC Encoding ID 1) or shall be formatted using the “Compact No-Code FEC scheme” (FEC Encoding ID 0) in RFC 5445 [42].

If the Raptor FEC scheme is used by an ATSC NRT transmitter, then the procedures specified in [43] and the ATSC NRT Raptor Parameter Derivation Algorithm for Content Delivery Protocol as specified in Section 5.4.2 to derive the FEC Object Transmission Information (FEC OTI) shall be applied. The Example Parameter Derivation Algorithm in [43], Section 4.2, shall not be used, and references in [43] to Example Parameter Derivation Algorithm in [43], Section 4.2, instead shall be redirected to reference the ATSC NRT Raptor Parameter Derivation Algorithm for Content Delivery Protocol as specified in Section 5.4.2.

If the Compact No-Code FEC Scheme is used by an ATSC NRT transmitter, then the procedures specified in [42] shall be applied and the FEC OTI shall be derived in such a way that no source block is of size greater than 262,144 bytes.

Note Even if no FEC repair is desired, at least one of the two specified FEC schemes is required to be used when transmitting an object, since it is the FEC scheme that specifies the FEC Payload ID that is included in all data packets, and the FEC Payload ID is used to identify where the payload bytes of source packets fit into the object. This information is not provided by the LCT protocol.

### 5.4.2 ATSC NRT Raptor Parameter Derivation Algorithm for Content Delivery Protocol

This section provides the derivation of the four transport parameters:

- T, the symbol size in bytes
- Z, the number of source blocks
- N, the number of sub-blocks in each source block
- G, the maximum number of symbols to be transported in a single packet

The previous four parameters are derived from the following input parameters:

- F, the transfer length of the object, in bytes
- W, a target on the sub-block size, in bytes, shall be set to  $W = 262,144$  bytes.
- Al, the symbol alignment parameter, in bytes, shall be set to  $Al = 4$ .
- P, the maximum packet payload size available for carrying symbols, in bytes
- SS a parameter such that the desired lower bound on the sub-symbol size is  $SS * Al$ . SS shall be chosen such that  $SS * Al$  is at most P and shall be set to  $SS = 8$ .
- Kmax the maximum number of source symbols per source block, shall be set to  $Kmax = 8192$ .
- Kmin a minimum target on the number of symbols per source block, shall be set to  $Kmin = 1024$ .
- Gmax a maximum target number of symbols per packet, shall be set to  $Gmax = 10$ .

Then

- $G = \min\{\text{ceil}(P * Kmin / F), \text{floor}(P / (SS * Al)), Gmax\}$
- $T = \text{floor}(P / (Al * G)) * Al$
- $Kt = \text{ceil}(F / T)$

- $N_{max} = \text{floor}(T/(SS*Al))$
- For all  $n = 1, \dots, N_{max}$ 
  - $KL(n)$  is the maximum  $K \leq K_{max}$  that satisfies
  - $K \leq \text{floor}(W/(Al*(\text{ceil}(T/(Al*n))))))$
- $Z = \text{ceil}(Kt/KL(N_{max}))$
- $N$  is the minimum  $n$  such that  $\text{ceil}(Kt/Z) \leq KL(n)$

Note that by the way  $G$  is calculated it is guaranteed that the symbol size  $T$  is at least  $SS*Al$ ; i.e., the symbol size is at least the minimum sub-symbol size.

Each transmitted packet shall contain at most  $G$  symbols. Note that  $T*G$  is at most  $P$ .

Example:

$SS = 8$

$Al = 4$  bytes

(Min sub-symbol size = 32 bytes)

$W = 262,144$  bytes

$P = 1,240$  bytes

$F = 400,000$  bytes

$K_{min} = 1,024$

$K_{max} = 8,192$

$G_{max} = 10$

$G = 4$

$T = 308$  ( $T*G = 1232$ )

$Kt = 1,299$

$N_{max} = 9$

$KL(N_{max}) = 7,281$

$Z = 1$

$\text{ceil}(Kt/Z) = 1,299$

$KL(1) = 851$

$KL(2) = 1,680$

$N = 2$

$TL = 39$ , larger sub-symbol = 156 bytes

$TS = 38$ , smaller sub-symbol = 152 bytes

$TL*Al*\text{ceil}(Kt/Z) = 202,644$  is the size in bytes of the largest sub-block

## 5.5 FDT Instance Compression

FDT Instances may be compressed for delivery using the DEFLATE algorithm [22]. When this is done, the ALC/LCT packets carrying such FDT Instances shall contain an LCT extension header of type EXT\_CENC with the CENC field set to 2.

Note: The current FLUTE RFC [23] states that the assignment of values to the CENC field is “outside the scope of this specification.” However, Internet Draft draft-ietf-rmt-flute-revised-11 (dated 25 March 2010) [67], which is due to become the current version of the FLUTE Internet Standard soon, defines the value 2 in the CENC field to indicate the DEFLATE algorithm.

## 5.6 File Compression

Files may be compressed for delivery using the DEFLATE algorithm specified in IETF RFC 1951 [22]. When this is done, the following requirements shall apply:

- The Content-Encoding attribute at either the FDT-Instance level or the File level for the file shall be set to the value “deflate”, in accordance with the IANA registry of Content-Encoding values [63].
- The Content-Location attribute for the file shall indicate the URI to be assigned to the file after it is decoded.

## 5.7 ZIP Archive Format

When it is desired to package a collection of files into a single file for transmission, a “ZIP archive” may be used. If used, it shall conform to the definition of “ZIP archive” in Section 10.2 of the ISO “Open Packaging Conventions” Standard ISO/IEC 29500-2 [44]. The extensions defined below may also be used.

When it is desired to compress all or some of the files in a ZIP archive, the DEFLATE compression method should be used.

A ZIP archive contains a sequence of file entries, each of which contains a “local file header”, “file data”, and optionally a “data descriptor”. This is followed by a “Central Directory Structure” containing a “file header” for each file in the archive. One of the fields in the “file header of the Central Directory Structure” is called the “extra field.” It is a field of variable size that can be used for special purpose extensions to the header.

### 5.7.1 Extension Structure

The “ZIP archive” specification states that when the “extra field” is used, its structure should be:

$$\text{header1} + \text{data1} + \text{header2} + \text{data2} + \dots$$

where each header should consist of a 2-byte Header ID field and a 2-byte Data Size field.

When the “extra field” is used in an ATSC NRT broadcast, it shall consist of a sequence of Extension() structures as defined in Table 5.2.

**Table 5.2** Extension Structure

Syntax	No. of Bits	Format
Extension() {		
ExtensionHeader() {		
HeaderID	16	uilsBf
DataSize	16	uilsBf
}		
ExtensionBody() {		
for (i=0; i<DataSize; i++)		
ExtensionData[i]	8	bslbf
}		
}		

**HeaderID** – An identifier which indicates the specific type of extension. Extension identifiers in the range 0 through 31 (0x0000 through 0x001F) are reserved. There is no registry for the

namespace for HeaderID values, although a list of values that are known to be used appears in the “ZIP archive” specification.

**DataSize** – The number of ExtensionData octets in the body of the Extension().

**ExtensionData[]** – The extension’s data, represented as a sequence of octets, the interpretation of which depends upon the extension type as indicated by HeaderID.

### 5.7.2 ATSC NRT Extensions

Extensions with HeaderID value 0xFFFF (identifying them as ATSC NRT extensions) and ExtensionBody in either of the forms defined in Table 5.3 and Table 5.4 may be used in ATSC NRT broadcasts<sup>2</sup>.

**Table 5.3** “HTTP Entity Header” ExtensionBody

Syntax	No. of Bits	Format
HEHEExtensionBody() {		
hehMarker	32	uilsWBf
hehNameLength	16	uilsBf
hehValueLength	16	uilsBf
for (i=0; i<hehNameLength; i++)		
hehName[i]	8	bslbf
for (i=0; i<hehValueLength; i++)		
hehValue[i]	8	bslbf
}		

**hehMarker** – A marker which provides additional assurance that this extension can be properly identified as an ATSC NRT extension, and which distinguishes it from an ATSC NRT Entry extension. This field shall be set to the constant value 0x4D494D45.

**hehNameLength** – The length of the hehName field in octets.

**hehValueLength** – The length of the hehValue field in octets.

**hehName[]** – This field contains a non-empty, non-terminated character string which specifies an HTTP entity header name, as defined in Section 7.1 of IETF RFC 2616 [25]. The character encoding of hehName[] shall be in accordance with [41].

**hehValue[]** – This field contains a non-empty, non-terminated character string which specifies an HTTP entity header value, as specified in IETF RFC 2616 [25]. The character encoding of hehValue[] shall be in accordance with [41].

A single central directory file header in a ZIP archive shall not have more than one HTTP Entity Header ExtensionBody whose hehName is the same string when compared using a case-insensitive comparison operation.

<sup>2</sup> With these specifications, an ATSC NRT extension is identified by the first two bytes having the value 0xFFFF and the next four bytes having either the value 0x4D494D45 or the value 0x454C5452. Since there is no registry for HeaderID values, it is possible, although extremely unlikely, that an extension defined for some other application could have these same values. Generators of ZIP archives to be included in an NRT broadcast should take care that no such conflicting extension for any other application appears in the archives.

When present, an HTTP Entity Header extension structure carrying a Content-Type HTTP Entity Header shall indicate the file type of the file in the ZIP archive corresponding to the central directory file header in which the extension appears.

**Table 5.4** “Entry” ExtensionBody

Syntax	No. of Bits	Format
EntryExtensionBody() { entryMarker }	32	uilsWBf

**entryMarker** – A marker which provides additional assurance that this extension can be properly identified as an ATSC NRT Entry extension, and which distinguishes it from an ATSC NRT HTTP Entry Header extension. This field shall be set to the constant value 0x454E5452.

When the ZIP archive itself is identified in the FLUTE FDT as an entry point for a content item, and when an Entry extension structure appears in the central directory file header for a file in the ZIP archive, this shall indicate that the file is an entry point for the content item.

The Content-Location for a particular file delivered in a ZIP archive shall be considered to be the concatenation of the Content-Location value of the ZIP archive file itself with the value of the “file name” field for the particular file in the Central Directory Structure of the ZIP archive.

## 5.8 Filename Extensions and Internet Media Types

If the URI in the Content-Location attribute for a file in the FLUTE FDT is hierarchical, as that term is defined in the IETF URI RFC [40], then the filename of the file is the last segment of the Content-Location value. If the URI is not hierarchical, then the filename of the file is undefined. For a file contained within a ZIP archive, the filename of the file is the last segment of the “file name” field in the “local file header” structure for the file.

In the case of an individual file delivered via FLUTE, the Content-Type of the file may be indicated by a Content-Type attribute in the FDT at either the FDT instance level or the File level. In the case of a file delivered within a ZIP archive, the Content-Type of the file may be indicated by a Content-Type value contained in an HEHExtensionBody of an Extension Structure in the “extra field” for the file in the Central Directory Structure of the ZIP archive.

Table 5.5 lists filename extensions that may be used to indicate the data types of files delivered via FLUTE. For each file extension it gives a corresponding data type (using the usual English language designation), Content-Type (i.e., MIME type or media type), and references to specifications for the media encoding, Content-Type and file format, when such specifications exist.

If the filename extension of a file delivered via FLUTE appears in the first column of Table 5.5, and if no Content-Type is included in the FLUTE FDT or the Central Directory structure of a ZIP archive for the file, then the data type of the file shall be the data type that appears in the second column of Table 5.5 in the row of the file's filename extension, the Content-Type shall be media type that appears in the fourth column, and the media encoding and file format shall be as specified in the references in the third column, or as specified in the text following Table 5.5 (for any case where the references give only the encoding format, not the complete file format).

If the filename extension of a file delivered via FLUTE does not appear in the first column of Table 5.5, then a Content-Type attribute for the file shall be included in the FLUTE FDT or the Central Directory structure of a ZIP archive as described above.

Whenever the Content-Type attribute for a file is included in the FLUTE FDT or the Central Directory structure of a ZIP archive as described above, the Content-Type attribute shall be a media type/subtype designation formed according to RFC 2045 [29], possibly augmented by encoding parameter values as specified by the standards defining specific media types. The designation may be an IANA registered media type or an unregistered media type in the case of experimental types (i.e., “x-“) and those in widespread commercial use (e.g., “audio/wav”). The data type of the file shall be the data type indicated by that media type value, regardless of the file's filename extension.

In cases when encoding parameters for a file are necessary in order for a receiver to determine whether or not it can decode the file, these parameters should be provided in the Content-Type attribute of the file, so receivers can decide ahead of time whether to download the file or not.

The registered media types can be found in the IANA Media Type Registry [64].

**Table 5.5** Filename Extensions and Content-Type Strings

Filename Extension	File Data Type	References	Content-Type
.ac3	AC-3 standalone audio	<ul style="list-style-type: none"> <li>• ATSC A/52 [1]</li> <li>• RFC 4184 [33]</li> <li>• Annex F of this document</li> </ul>	audio/ac3
.atom	Atom syndication format	<ul style="list-style-type: none"> <li>• RFC 4287 [36]</li> </ul>	application/atom+xml
.dtshd	DTS-HD Audio Elementary Stream File Format	<ul style="list-style-type: none"> <li>• ETSI TS 102 114 v1.3.1 [19]</li> <li>• Annex E of this document</li> </ul>	audio/vnd.dts.hd
.ec3	Enhanced AC-3 standalone audio	<ul style="list-style-type: none"> <li>• ATSC A/52 [1]</li> <li>• RFC 4598 [32]</li> <li>• Annex F of this document</li> </ul>	audio/eac3
.es	ECMAScript	<ul style="list-style-type: none"> <li>• ECMA-262 [18]</li> <li>• RFC 4329 [34]</li> </ul>	application/ecmascript
.gif	GIF graphics	<ul style="list-style-type: none"> <li>• CEA-2014-B [16]</li> <li>• RFC 2046 [30]</li> </ul>	image/gif
.htm .html	HTML	<ul style="list-style-type: none"> <li>• W3C HTML Spec [57]</li> <li>• RFC 2854 [38]</li> </ul>	text/html
.jpg .jpeg	JPEG graphics	<ul style="list-style-type: none"> <li>• ATSC A/100-1 [12]</li> <li>• RFC 2046 [30]</li> </ul>	image/jpeg
.m4a	AAC standalone audio	<ul style="list-style-type: none"> <li>• ISO/IEC 14496-3 [46]</li> <li>• ISO/IEC 14496-12 [51]</li> <li>• ISO/IEC 14496-14 [52]</li> <li>• RFC 4337 [28]</li> </ul>	audio/mp4
.mp3	MP3 standalone audio (MPEG-1) or MPEG-2 level III audio)	<ul style="list-style-type: none"> <li>• ISO/IEC 11172-3 [49]</li> <li>• ISO/IEC 13818-3 [50]</li> <li>• RFC 3003 [37]</li> </ul>	audio/mpeg
.uvu	DECE CFF file	<ul style="list-style-type: none"> <li>• DECE CFF specification[17]</li> </ul>	video/vnd.dece.mp4
.png	PNG graphics	<ul style="list-style-type: none"> <li>• ISO/IEC 15948 [47]</li> <li>• RFC 2083 [31]</li> </ul>	image/png
.sdp	SDP file	<ul style="list-style-type: none"> <li>• RFC 4566 [35]</li> </ul>	application/sdp
.txt	Text (plain)	<ul style="list-style-type: none"> <li>• RFC 2046 [30]</li> </ul>	text/plain
.zip	ZIP	<ul style="list-style-type: none"> <li>• ISO/IEC 25900-2 [48]</li> </ul>	application/zip

The file format associated with the “.m4a” filename extension in Table 5.5 shall conform to the specifications in the ISO Base Media file format [51] and the MP4 file format [52], with the constraints listed in Annex A.2.4 of this document.

In the case of the “.mp3” filename extension, RFC 3003 does not explicitly specify a file format for audio/mpeg files. The file format associated with the “.mp3” filename extension in Table 5.5 shall be a sequence of audio frames, just as they come out of the audio encoder, with optional blocks of metadata, such as ID3 blocks [66], at the beginning or end of the file.

In all cases, after files are received, receivers will need to ensure that some kind of indicator of the media type of each file is stored along with the file, so that they will know how to render the file, to ensure that the stored content can be rendered. The capability codes listed in Annex A are one such indicator.

## 5.9 File Names and Hyperlink Resolution

The URL conventions specified in this section are intended to accomplish three things:

- Enable receivers to distinguish between files that are only available via FLUTE and files that are available via both FLUTE and an Internet link.
- Facilitate using relative URLs for files delivered by FLUTE, rather than longer absolute URLs.
- Support hyperlink resolution among the files within a FLUTE session in much the same way as it works for files in a computer's file system.

The URL conventions are:

- 1) When a file is available both via FLUTE and over the Internet, the value of the Content-Location element of the file in the FLUTE FDT shall match the URL used to access the file over the Internet. (When an IRI (Internationalized Resource Identifier) is used to identify the file location, the "Mapping of IRIs to URIs" specified in Section 3.1 of IETF RFC 3987 [26] must be applied before matching it to the Content-Location element, in keeping with the following statement in RFC 3987 [26]: "However, when an IRI is used for resource retrieval, the resource that the IRI locates is the same as the one located by the URI obtained after converting the IRI according to the procedure defined here.") Note that an internal proxy web server or special browser cache management could be needed in a receiver in order to avoid retrieving such a file from the Internet even when it has already been extracted from a FLUTE session.
- 2) The Content-Location value for a FLUTE file may be an absolute URL or a relative URL. If the Content-Location value is an absolute URL, that URL is the absolute URL for the file. If the Content-Location value is a relative URL, the file shall be deemed to have an absolute URL of form:

`file://X/<content-location>`

where <content-location> is its Content-Location value, and "X" is an arbitrary virtual folder designation that represents the FLUTE session delivering the file and is disjoint from the virtual folders of all other FLUTE sessions known to the receiver. Note that since the folder designation is unspecified, it is only possible to reference such a file via relative hyperlinks that come from within the same FLUTE session. Moreover, because of condition (1), such a file cannot be available via an Internet link.

- 3) The "tag" URI scheme defined in RFC 4151 [68] may be used for the Content-Location value of FLUTE files, with the added constraint that the "specific" part of the URL shall conform to the syntax and semantics of the <hier\_part> of an absolute URI, as that term is defined in RFC 2396 [40]. Note that such a file can be referenced from anywhere, since a "tag" URI is required by RFC 4151 [68] to be globally unique, but as with any FLUTE file the engine resolving the reference needs to know a set of FLUTE session(s) in which to look for the file. Note also that such a file cannot be available over the Internet, because of condition (1).
- 4) FLUTE files that are not available over the Internet should have either a relative URL or an absolute "tag" URI as their Content-Location value. (If this recommendation is not followed, then receivers with an Internet connection are likely to waste time looking on the Internet for files that are not there, to the detriment of the viewer experience with any service where this happens.)

- 5) The base URI for resolving relative hyperlinks within a FLUTE file shall be the absolute URL of the file, as defined in (2) above, with the last path segment removed.

An absolute URL of type 1 or 3 may be used as a reference to the file from anywhere, including from within a file that is part of a different content item from the referenced file. The same absolute URL of type 1 or 3 may be used as the Content-Location for files delivered in different services (i.e., separate FLUTE sessions. In this case, the file delivered must be the same.

### 5.10 Buffer Model

The NRT service FLUTE file packets are permitted to use the entire transport up to the maximum bitrate (e.g., 19.4 Mbps for fixed), less signaling overhead. The transport buffer model for the FLUTE file packets is therefore defined fully by the transport without further constraint. Packets may arrive at the full rate into a single socket buffer.

The signaling tables and other critical data may be subject to a simple smoothing buffer with a fixed buffer size and leak rate on a socket-by-socket basis. See ISO 13818-1, Section 2.4.2 [53] for background. The buffer model is applied after reception of the IP packet and IP address and UDP port filtering. So, this is a “socket” buffer model that applies to UDP packets.

The buffer size shall be 65536 bytes. The leak rate shall be  $1.2 \times 250$  Kilobits per second = 300 Kilobits per second.

Entire IP packets enter the socket buffer instantaneously after address and port filtering. Bytes leave the buffer at the leak rate. The transport shall be constructed such that this modeled buffer does not overflow, but may underflow.

The Service Signaling Channel socket {224.0.23.60:4937} shall be subject to this buffer model.

As in all buffer models, this is an encoder constraint on the bitstream construction, not a decoder design guide. It is intended to constrain the burstiness of the tables to ensure more reliable decoder buffering and processing.

### 5.11 Content Update Notification

Non-Real-Time services will usually retransmit content files throughout the announced availability window, because different receivers are expected to begin listening to a broadcast at different times within that window. In the simplest use cases, the set of files available is fixed for the whole of an NRT session. However, dynamic update of available content is also supported within this Standard. (The signaling that indicates that updates may occur within a given NRT service is described in Sections 6.3 and 7.2.4.3.)

As described in Section 5.2, content files are delivered using the FLUTE protocol. When a new file is added or an existing file is updated, a receiver processing the packets transmitted within a FLUTE session is able to detect the update as follows.

FLUTE packets include a header that identifies the TOI of the file with which the packets are associated. A new or updated file will have a new and (sufficiently) unique TOI. Moreover, the FDT provides a table of contents for the session, and this table changes when a file is added (new Content-Location) or updated (new TOI associated with existing Content-Location). In addition, the packets for the FDT themselves have a header field (FDT Instance ID) that is updated when the FDT changes.

In a generic FLUTE session, once all files announced in some version of the FDT have been acquired, a receiver can monitor for updates as follows:

- Continuously or intermittently process packets for the NRT service of interest.
- Examine the FLUTE header of each received packet. If it's not an FDT packet (TOI = 0), ignore it.
- If TOI = 0, examine the FDT Instance ID header of this FDT packet. If this FDT Instance ID is not greater than the last known (rollover being taken into account), ignore the packet.
- If the FDT Instance ID has increased, process the FDT and acquire any new or updated files (i.e., TOIs not seen before).

A receiver may also recognize new TOIs in the packet stream and preemptively store or process them while awaiting the FDT.

#### 5.11.1 Update Notification

Once a receiver has acquired the content files described in the FDT it discovered on first processing a FLUTE session, most of the packets subsequently received may be retransmissions; i.e., be marked with TOIs the receiver has already processed. The process sketched above requires header inspection of every packet received in every session for which updates are expected. Since the total bitrate of all NRT sessions may be quite high, especially in the fixed NRT broadcast case, the process above may be problematic for some receivers.

Therefore, a FLUTE usage is defined that allows the transmitter of a high bitrate NRT service to enable a receiver to avoid examining every packet header. It makes use of the ability within the FLUTE protocol to deliver the UDP packets for a single FLUTE session on multiple LCT channels (i.e., destination multicast IP address/port combinations). The employment of this usage must be signaled to receivers as described in Section 6.2.3.

##### 5.11.1.1 Transmission Characteristics

When the usage described above is employed for a specific FLUTE session, the packets of the FLUTE session shall be delivered using two (or more) LCT channels that use the same destination IP address and a consecutively numbered range of ports. The lowest (base) port is to be interpreted as a special ("update") channel.

The packet stream on the update channel shall include only FDT instances. The FDT shall describe all files in the session. The FDT shall be sent continually, often enough to allow a receiver that joins the session to determine what needs to be acquired (if a new listener) or whether up to date (if an intermittent listener). Note that the latter may be unavoidable if multiple NRT services on different broadcasts need to be monitored; a receiver may need to sample different frequencies, looking for updates. The exact FDT repetition rate is up to the transmitter, and will depend on the NRT application mode, user experience requirements, number of files and bitrate available.

The packet stream(s) associated with the remaining channels (i.e., same source IP, TSI, multicast IP, but higher port(s) than the update channel) shall be used to transmit files announced in the FDT; i.e., data objects with TOI greater than 0. Optionally, the FDT may also be sent on these channels.

#### 5.11.1.2 Receiver Behavior

A receiver that does not require the processing overhead optimization this usage provides (or is unaware of the usage altogether), will process all packets from all channels signaled as part of the FLUTE session.

A receiver that detects this usage and wishes to detect updates but reduce packet processing should behave as follows:

- When the FLUTE session is first joined, process packets from all channels signaled for that session.
- (Steady state) Once all files described in the FDT have been acquired (or filtered out), stop processing packets for any channel other than the update channel.
- Process packets from the update channel continuously or intermittently. Examine the header of any FDT packets to determine if there have been any content updates, as described above.
- If the FDT Instance ID changes, process packets from all channels and acquire any new files.
- Once all files described in the FDT have been acquired, return to steady state.

### 5.12 File Delivery to Support RME Streams

FLUTE sessions used for delivery of external resources to support streamed RME data are not included as a defined NRT service nor as defined NRT adjunct components in this Standard.

However, notwithstanding lack of specific details for such inclusion, if transmitted, such FLUTE sessions shall conform to all of the provisions of Section 5 of this ATSC NRT Standard except for those in Section 5.3 (content linkage). Note especially that the provisions of Section 5.9 on File Names and Hyperlink Resolution apply.

When external resources referenced in streamed RME data are delivered as files via the FLUTE protocol, the value of the Content-Location field for each file in the FLUTE FDT shall match the value of the IRI that references the file from the streamed RME data, if necessary applying the “Mapping of IRIs to URIs” that is specified in Section 3.1 of IETF RFC 3987 [26] before making the comparison.

A Capabilities Descriptor (defined in Section 8.3 of this Standard) may appear in the service level descriptor loop of a service containing such FLUTE delivery of RME external resources, to indicate the capabilities needed to retrieve and render the external resources.

## 6. SIGNALING AND ANNOUNCEMENTS FOR FIXED NRT BROADCASTS

### 6.1 Non-Real-Time Services

Non-Real-Time services in the fixed-broadcast emission can be provided as standalone services in virtual channels that contain only NRT services, or as adjunct services in other types of fixed-broadcast services. In either case the NRT services shall appear in the IP subnet of a virtual channel, as defined in Section 5.1.1 of this Standard.

A single subnet may contain multiple NRT services.

All the NRT services in an IP subnet shall be signaled in the subnet’s Service Map Table, defined in Section 6.2.

### 6.1.1 Standalone NRT Services

Fixed-broadcast virtual channels containing exclusively non-real-time elements shall be identified by the value 0x08 in the field `service_type` in the Virtual Channel Table (`terrestrial_virtual_channel_table_section()` or `cable_virtual_channel_table_section()`) (see A/65 [13]).

Virtual channels associated with this type of service carry only file-based content, such as A/V clips, full-length programming, and textual/graphics information.

### 6.1.2 Adjunct NRT Services

NRT services can be present within other types of virtual channels (i.e., virtual channels with `service_type` other than 0x08). Such services are called adjunct NRT services.

### 6.1.3 NRT Protocol Version Identification

All the components of a given NRT service in a fixed-broadcast emission shall conform to the same major/minor protocol version of the NRT Standard. This major/minor protocol version is called the NRT protocol version of the service. A change in the major version level indicates a non-backward-compatible level of change. A change in the minor version level, provided the major version level remains the same, indicates a backward-compatible level of change.

If all the NRT services in the IP subnet of a virtual channel conform to the same version of the NRT standard, a Protocol Version Descriptor with `protocol_identifier` value 0x03 shall appear in the `subnet_level` descriptor loop of the SMT (as described in Section 6.2.1) to indicate the common NRT protocol version of all the NRT services. If the IP subnet of the virtual channel contains NRT services of different protocol versions, Protocol Version Descriptors with `protocol_identifier` value 0x03 shall appear in the service level descriptor loops for those services in the SMT to identify the individual NRT protocol versions of those services.

There is an expectation that receivers will not offer to the user NRT services labeled with a value of `major_protocol_version` higher than that for which the receiver was built to support. Receivers are not expected to use `minor_protocol_version` as a basis for *not* offering a given service to the user. Receivers are expected to use `minor_protocol_version` to determine whether the transmission includes data elements defined in later versions of the Standard<sup>6</sup>.

### 6.1.4 Service Signaling Channel

As specified in section 5.1.1, an IP subnet carrying NRT components contains a Service Signaling Channel (SSC), defined as those IP packets in the subnet with IP multicast address 224.0.23.60 and UDP port 4937. This SSC shall contain the following signaling tables:

- The Service Map Table (SMT), as defined in Section 6.2 of this Standard, and
- One or more Non-Real-Time Information Tables (NRT-IT), as defined in Section 6.3 of this Standard.

The following optional tables are defined to be part of the SSC, when sent:

- One or more Text Fragment Tables (TFT), as defined in Section 6.4 of this Standard,
- One or more Targeting Criterion Tables, as defined in Section 9.4 of this Standard, and
- Purchase information tables, as defined in Section 6.5 of this Standard.

---

<sup>6</sup> A field defined in the current version of this Standard as “reserved” may be defined in a future version as conveying a certain meaning dependent upon the value of `minor_protocol_version`. A field may, for example, be defined as reserved for `minor_protocol_version` values 0 and 1, and given a specific meaning beginning at `minor_protocol_version` 2.

All IP packets of the Service Signaling Channel for a virtual channel shall appear in a single program element of the virtual channel. That program element may contain one or more services along with the Service Signaling Channel. No other IP packets shall appear in the SSC when the `major_protocol_version` field of the SMT is set to 0x01. Receivers are expected to ignore any unknown structures found in the SSC.

#### 6.1.5 Structure of SSC Tables

The Service Signaling Channel (SSC) tables defined by this standard are modeled after the Generic Table Format defined in the ATSC Mobile DTV standard, Part 3 [7], Section 7.1 (which is in turn modeled after the MPEG-2 `private_section` generic syntax defined in the MPEG-2 Systems standard [53], sections 2.4.4.10 and 2.4.4.11). However, the SSC table sections defined in this standard differ from the Generic Table Format in that in some cases the definition of “table” used for the purposes of versioning and section numbering is based on the values of a larger set of fields than just the `table_id` and `table_id_extension`. The definition of each table in this standard includes a specification of the set of fields used to identify a “table” for versioning and section numbering purposes.

Fields in SSC table sections that have the same names as fields in the Generic Table Format shall have the same semantics as those fields in the Generic Table Format, unless otherwise redefined in the semantic definitions following the syntax definition for the SSC table section.

Except where indicated otherwise, any SSC table field that is identified as a text string shall be UTF-8 [41] encoded.

## 6.2 Service Map Table (SMT)

The Service Map Table (SMT) contains service-level attributes for NRT Services carried in the fixed-broadcast Transport Stream. The structure defined hereinunder is signaled by the Protocol Version Descriptor with the `protocol_identifier` field set to 0x03, `major_protocol_version` field set to 0x01 and `minor_protocol_version` field set to 0x01. The bit stream syntax and semantics of this SMT shall be identical to the Service Map Table for M/H services defined in A/153 Part 3 [7] Section 7.3, with the following exceptions:

- References to “M/H Services” shall be considered references to “IP Subnet Services”.
- The concept of ensemble is inapplicable to fixed-broadcast transport. The `multi_ensemble_service` field shall be reserved and set to ‘11’ for fixed-broadcast use of the SMT.
- The `ensemble_id` field shall be renamed `subnet_id` for fixed broadcasts, with the following semantics:
  - subnet\_id** – This 8-bit unsigned integer shall indicate the IP subnet associated with this service signaling channel. The scope of `subnet_id` shall be the full main broadcast Transport Stream. If NRT services are present in both ‘fixed’ and ‘mobile’ streams the value in the `subnet_id` field (in a fixed stream) should be different from the value in the `ensemble_id` field (in any mobile stream). Receivers should retain the separate identity of each source.
- The `SMT_MH_protocol_version` field shall be renamed to `SMT_protocol_version` for fixed broadcasts, with the following semantics:
  - SMT\_protocol\_version** – The most significant 4 bits of this 8-bit unsigned integer shall indicate the major version number of the SMT, and the least significant 4 bits shall

- indicate the minor version number of the SMT. For the table defined in this standard the major version number shall be “1”, and the minor version number shall be “0”.
- The `num_ensemble_level_descriptors` field shall be renamed `num_subnet_level_descriptors` for fixed broadcasts, with the following semantics:  
**num\_subnet\_level\_descriptors** – This 4-bit unsigned integer number in the range 0 to 15 shall indicate the number of subnet-level descriptors to follow.
  - The `ensemble_level_descriptor()` field shall be renamed `subnet_level_descriptor()` for fixed broadcasts, with the following semantics:  
**subnet\_level\_descriptor()** – Zero or more descriptors providing additional information pertaining to the NRT services carried in this IP subnet may be included.
  - The following fields shall be renamed as indicated:  
“MH\_service\_id” renamed to “service\_id”  
“MH\_service\_status” renamed to “service\_status”  
“short\_MH\_service\_name\_length” renamed to “short\_service\_name\_length”  
“short\_MH\_service\_name” renamed to “short\_service\_name”  
“MH\_service\_category” renamed to “service\_category”  
“num\_MH\_service\_level\_descriptors” renamed to “num\_service\_level\_descriptors”  
“MH\_service\_level\_descriptor()” renamed to “service\_level\_descriptor()”
  - For NRT services the `service_category` field shall be set to 0x0E.

The following provisions apply to the delivery of the SMT in the Service Signaling Channel:

- For each IP subnet, SMT sections describing all the NRT services of that IP subnet shall be included in that IP subnet.
- Each SMT section shall be contained within a single IP multicast datagram.
- Different SMT sections shall be contained in different datagrams.
- The repetition rate of the SMT should be set by the broadcaster to a rate commensurate with the desired user experience.<sup>7</sup>
- The SMT sections for each IP subnet shall be differentiated via the `subnet_id` included in the section header.

Any changes in the contents of the SMT (which would reflect changes in the NRT Service line-up or properties) shall be conveyed in a new SMT carrying an incremented version number. The information contained in the SMT includes service acquisition information for the IP streams that form each NRT service, such as destination multicast IP address and destination UDP port number. The set of SMT sections in a given IP subnet shall include information for all NRT Services that are carried (wholly or partially) in that IP subnet.

#### 6.2.1 Subnet-Level SMT Descriptors

Subnet level descriptors may appear within the SMT in the location indicated by the field name `subnet_level_descriptor()` to describe attributes common to the entire subnet.

When all the services of `service_category` 0x0E in the subnet are of the same NRT protocol version, this subnet-level descriptor loop shall contain a Protocol Version Descriptor with

---

<sup>7</sup> The rate should be set high enough that most users do not encounter what looks like an unresponsive or vacant channel when accessing the NRT service.

protocol\_identifier value 0x03 and major/minor\_protocol\_version fields indicating the NRT protocol version of the NRT services.

Other descriptors may also appear in the subnet level descriptor loop.

#### 6.2.2 Service-Level SMT Descriptors

Service level descriptors may appear within the SMT in the location indicated by the field name service\_level\_descriptor() to describe attributes of a given NRT service. Service level descriptors defined for use in the SMT are listed in Table 6.1. Certain service-level descriptors shall always be present, as indicated below and in Table 6.1.

For each NRT service (those identified by service\_category value 0x0E), the SMT shall include one NRT Service Descriptor and one or more Capabilities Descriptors at the service level. If the services of service\_category 0x0E in the subnet are not all of the same NRT protocol version, then the service level descriptor loop for each service in the SMT shall contain a Protocol Version Descriptor with protocol\_identifier value 0x03 and major/minor protocol version fields indicating the NRT protocol version of that service.

Other descriptors besides those listed in Table 6.1 may also appear in the service level descriptor loop.

**Table 6.1** Service-Level Descriptors in the Service Map Table

Descriptor Name	Descriptor Tag	Reference and Description
Protocol Version Descriptor	0xC3	Section 8.1. Shall indicate the NRT protocol version number of the NRT service if that has not already been signaled by a Protocol Version Descriptor at the subnet level in the SMT..
NRT Service Descriptor	0xC4	Section 8.2. Shall indicate the presence of NRT service components, identify the consumption model of the NRT service, and provide other optional information about the service..
Capabilities Descriptor	0xC5	Section 8.3. Shall list protocols (download protocols, FEC protocols, wrapper/archive protocols, compression protocols, and media formats) for which support is deemed essential to a meaningful presentation of this NRT service, and may optionally list non-essential protocols used for this service as well. (Contains indicators showing which protocols are essential and which are not.)
Icon Descriptor	0xC6	Section 8.4. When present, shall provide the content-linkage (FDT file reference) for an icon that may be used to represent the NRT service.
ISO-639 Language Descriptor	0x0A	Section 8.5. When present, shall indicate the default language of audio, closed captioning and/or textual components of this NRT service. One descriptor may include one or more language identifiers. This descriptor may be overridden for individual content items by ISO-639 Language Descriptors in the NRT-IT.
Receiver Targeting Descriptor	0xC7	Section 9.2. When present, shall provide default targeting criterion values to indicate the receivers to which the service is targeted. This descriptor may be overridden for individual content items by Receiver Targeting descriptors in the NRT-IT.
Genre Descriptor	0xAB	A/65 [13], Section 6.9.13, Section 6.9.13. When present, shall indicate one or more default Genre categories associated with this NRT service. This descriptor may be overridden for individual content items by Genre descriptors in the NRT-IT.
ATSC Private Information Descriptor	0xAD	A/53 Part 3 [3] Section 6.8.4. Usable for private information associated with this NRT service.

### 6.2.3 Component-Level SMT Descriptors

Descriptors may also appear within the SMT in the location indicated by the term `component_descriptor()` to describe attributes of components of a given NRT service. The component types applicable to NRT services are listed in Table 6.2.

The “`MH_component_descriptor()`” defined in A/153 Part 3 [7] shall be renamed “`component_descriptor()`” for fixed NRT broadcasts, and its “`MH_component_data`” field shall be renamed “`component_data`.”

All FLUTE sessions delivering files for an NRT service shall be signaled in the SMT by means of components with a `component_descriptor()` of `component_type 38` (FLUTE file delivery component).

Other component-level descriptors besides those listed in Table 6.2 may also appear in the component-level descriptor loop.

**Table 6.2** Component-Level Descriptors in the Service Map Table

Descriptor Name	Descriptor Tag	Reference and Description	
Component Descriptor	0xBC	The following component types are applicable for use with NRT services. The syntax and semantics of the FLUTE file delivery component is as specified in A/153 Part 3 [7] Section 7.8.1, extended as specified in Section 8/6 of this Standard.	
		component type	Meaning
		38	FLUTE file delivery component.

### 6.3 Non-Real-Time Information Table (NRT-IT)

The Non-Real-Time Information Table (NRT-IT) contains information describing content items available for download to storage in the receiving device. The information provided in the NRT-IT includes the title of the content item (for example, the name of the program available for download), the times during which the content item is to be made available for download, and information such as content advisories, availability of caption services, content identification, and other metadata.

One content item may consist of one or more files. For example, it could consist of a collection of audio/video clips, together with an HTML page which can be presented to a viewer to allow the viewer to select clips to play.

There shall be one NRT-IT for each NRT service (service with `service_category` value 0x0E). Each NRT-IT may consist of multiple NRT-IT Instances.

Unlike the PSIP EIT [13], in which each instance corresponds to a 3-hour time slot, an NRT-IT Instance can include data corresponding to an arbitrarily defined time period, or it can describe NRT content starting at a specified time and extending into the indefinite future. Each NRT-IT Instance indicates the start time of the period (`time_span_start`) it covers and the length of the period (`time_span_length`) it covers (which may be indefinite).

The time periods of NRT-IT Instances for the same NRT service shall not overlap.

Each NRT-IT instance may be segmented into as many as 256 sections. One section may contain information for multiple content items, but the information for any given content item shall not be segmented and put into two or more sections.

A content item belonging to a service shall be eligible to be included in an NRT-IT Instance for that service if any of the time periods when it is scheduled to be made available in the broadcast overlap the time period covered by the NRT-IT Instance. When a content item is eligible to be included in multiple NRT-IT instances, it shall be included only in the first of those NRT-IT Instances.

When the NRT-IT instance that includes such a content item expires, if the content item is still available, it will need to be placed into the next NRT-IT instance for which it is eligible.

Service providers need to be aware that for many types of NRT services, especially “browse and download” services with relatively large content items, it is very important to announce the content items well ahead of time, so that the user can request the desired content items and arrange for the receiving device to be “tuned” to the service during the time intervals when they are being transmitted.

Content item descriptions shall be placed within the `NRT_information_table_section()` in the order of their first availability. Therefore, when `last_section_number` is greater than zero (meaning the NRT-IT is delivered in multiple sections), for sections other than the first (sections for which the

value of `section_number` is greater than zero), all the content item descriptions within a given section shall have first availability times that are greater than or equal to all first availability times of content item descriptions in the immediately preceding section (the section whose value of `section_number` is one lower than the given section). The contents of the fields and descriptors for each content item shall be accurate representations of the known information about the content item at the time the content item instance is created and shall be updated if more accurate information becomes available.

The Non-Real-Time Information Table is carried in table sections with `table_id` 0xDF.

The IP multicast packets carrying the NRT-IT Instance sections for a service shall be in the Service Signaling Channel of the IP subnet carrying the service; i.e., their IP multicast address and port shall match the address and port for the SSC, as specified in Section 6.1.4 of this Standard.

The following constraints apply to the IP packets carrying the NRT-IT sections:

- There shall be no more than one NRT-IT section in a single IP packet.
- Different NRT-IT sections shall be in different IP packets.

The `NRT_information_table_section()` is modeled after the `MH_service_signaling_table_section()` defined in A/153 Part 3 [7], Section 7.1. Unless otherwise defined below, identically-named fields in the `NRT_information_table_section()` shall be as defined as in the `MH_service_signaling_table_section()` in A/153 Part 3 [7], Section 7.1. The bit stream syntax for the Non-Real-Time Information Table sections shall be as shown in Table 6.3. The semantics of the fields in this Table are specified immediately after the Table.

**Table 6.3** Bit Stream Syntax for the Non-Real-Time Information Table

Syntax	No. Bits	Format
NRT_information_table_section() {		
<b>table_id</b>	8	0xDF
<b>section_syntax_indicator</b>	1	'0'
<b>private_indicator</b>	1	'1'
<b>reserved</b>	2	'11'
<b>section_length</b>	12	uimsbf
table_id_extension {		
<b>protocol_version</b>	8	uimsbf
<b>subnet_id</b>	8	uimsbf
}		
<b>reserved</b>	2	'11'
<b>NRT_IT_version_number</b>	5	uimsbf
<b>current_next_indicator</b>	1	'1'
<b>section_number</b>	8	uimsbf
<b>last_section_number</b>	8	uimsbf
<b>service_id</b>	16	uimsbf
<b>time_span_start</b>	32	uimsbf
<b>reserved</b>	5	'11111'
<b>time_span_length</b>	11	uimsbf
<b>num_content_items_in_section</b>	8	uimsbf
for (j=0; j< num_content_items_in_section; j++) {		
<b>content_linkage</b>	32	uimsbf
<b>updates_available</b>	1	bslbf
<b>TF_available</b>	1	bslbf
<b>content_security_conditions_indicator</b>	1	bslbf
<b>reserved</b>	1	'1'
<b>playback_length_included</b>	1	bslbf
<b>playback_delay_included</b>	1	bslbf
<b>expiration_included</b>	1	bslbf
<b>content_size_included</b>	1	bslbf
<b>available_on_internet</b>	1	bslbf
<b>available_in_broadcast</b>	1	bslbf
<b>reserved</b>	6	'111111'
if (playback_length_included==1) {		
<b>reserved</b>	4	'1111'
<b>playback_length_in_seconds</b>	20	uimsbf
}		
if (playback_delay_included==1) {		
<b>reserved</b>	4	'1111'
<b>playback_delay</b>	20	uimsbf
}		
if (expiration_included==1) {		
<b>expiration</b>	32	uimsbf
}		
if (content_size_included==1) {		
<b>content_size</b>	40	uimsbf
}		

<pre>         }         content_name_length         content_name_text()         num_content_descriptors         for (i=0; i&lt;num_content_descriptors; i++) {             content_descriptor()         }     }     num_descriptors     for (i=0; i&lt;num_descriptors; i++) {         descriptor()     } } </pre>	8	uimsbf
<pre>         }         content_name_length         content_name_text()         num_content_descriptors         for (i=0; i&lt;num_content_descriptors; i++) {             content_descriptor()         }     }     num_descriptors     for (i=0; i&lt;num_descriptors; i++) {         descriptor()     } } </pre>	var	
<pre>         }         content_name_length         content_name_text()         num_content_descriptors         for (i=0; i&lt;num_content_descriptors; i++) {             content_descriptor()         }     }     num_descriptors     for (i=0; i&lt;num_descriptors; i++) {         descriptor()     } } </pre>	8	uimsbf
<pre>         }         content_name_length         content_name_text()         num_content_descriptors         for (i=0; i&lt;num_content_descriptors; i++) {             content_descriptor()         }     }     num_descriptors     for (i=0; i&lt;num_descriptors; i++) {         descriptor()     } } </pre>	var	

**table\_id** – This 8-bit field shall be set to 0xDF to identify this table section as belonging to the Non-Real-Time Information Table.

**protocol\_version** – This 8-bit unsigned integer field shall be set to 0x10, where the high order 4 bits indicate the major version number and the low order 4 bits indicate the minor version number. The function of protocol\_version is to allow, in the future, this table type to carry parameters that might be structured differently than those defined in the current protocol. New values of protocol\_version may be used by future versions of this standard to indicate structurally different tables.

**subnet\_id** – This 8-bit unsigned integer shall indicate the IP subnet associated with this service signaling channel.

**NRT\_IT\_version\_number** – This 5-bit field shall indicate the version number of this entire NRT-IT instance. Each NRT-IT instance shall be identified by the combination of the values in service\_id, table\_id, table\_id\_extension, and time\_span\_start. The version number shall be incremented by 1 modulo 32 when any field in the NRT-IT instance changes.

**current\_next\_indicator** – This 1-bit indicator shall always be set to ‘1’ for NRT-IT sections; the NRT-IT sent is always currently applicable.

**section\_number** – This 8-bit field shall give the section number of this NRT-IT Table Instance section, where the NRT-IT Table Instance is identified by the combination of table\_id, table\_id\_extension, service\_id and time\_span\_start fields. The section\_number of the first section in an NRT-IT Table Instance shall be 0x00. The section\_number shall be incremented by 1 with each additional section in the NRT-IT Table Instance.

**last\_section\_number** – This 8-bit field shall give the number of the last section (i.e., the section with the highest section\_number) of the NRT-IT Table Instance of which this section is a part.

**service\_id** – This 16-bit field shall specify the service\_id associated with the NRT service offering the content items described in this section.

**time\_span\_start** – This 32-bit unsigned integer shall represent the start of the time span covered by this instance of the NRT-IT, expressed as the number of GPS seconds since 00:00:00 UTC, 6 January 1980. The time of day of time\_span\_start shall be aligned to minute 00 of the hour. The value zero for time\_span\_start shall indicate the time period covered by his NRT-IT instance began in the indefinite past. The value of time\_span\_start shall be the same for each section of a multi-sectioned NRT-IT instance. The values of time\_span\_start and time\_span\_length shall be set

such that the specified time span does not overlap with any other NRT-IT instance in this IP subnet.

**time\_span\_length** – This 11-bit unsigned integer field in the range 0 to 1440 shall indicate the number of minutes, starting at the time indicated by `time_span_start`, covered by this instance of the NRT-IT. Once established, the value of `time_span_length` for a given value of `time_span_start` shall not change. A value of `time_span_length` of zero shall mean this NRT-IT instance covers all time starting at `time_span_start` into the indefinite future. If the value of `time_span_start` is zero, `time_span_length` shall have no meaning and shall be set to zero. The value of `time_span_length` shall be the same for each section of a multi-sectioned NRT-IT instance. The values of `time_span_start` and `time_span_length` shall be set such that the specified time span does not overlap with any other NRT-IT instance in this IP subnet.

**num\_content\_items\_in\_section** – This 8-bit unsigned integer field shall indicate the number of content items described in this NRT-IT section.

**content\_linkage** – This 32-bit unsigned integer field in the range 0x00000001 to 0xFFFFFFFF shall specify the identification number of the content item described. Value 0x00000000 shall not be used. The `content_linkage` performs two linkage functions: it links metadata in the NRT-IT to one or more files in the FLUTE FDT associated with this NRT content item; it also forms the `TF_id` (identifier for Text Fragment in Text Fragment Table). Each file associated with the content item shall have a FLUTE FDT content linkage tag matching the value of this `content_linkage` field (where “content linkage tag” is defined in Section 5.3). For a particular NRT service, the value of `content_linkage` shall be unique over the set of linkage values for all content items and icons in the service from the time when the content item or icon descriptor first appears in the NRT-IT or any of its files appear in FLUTE FDT instances to the time when the content item or icon descriptor no longer appears in the NRT-IT and none of its files appear in FLUTE FDT instances (taking into account the “Expires” attribute of the FLUTE FDT instances).

**updates\_available** – This Boolean flag shall specify, when set to ‘1,’ that the referenced content item(s) will be updated periodically: for content items delivered in FLUTE sessions, receiving devices are expected to monitor for changes the TOI associated with each file+ associated with the given value of `content_linkage`. When the `updates_available` flag is set to ‘0,’ updates are not expected to be provided for the associated content item(s), and receivers are not expected to look for them.

**TF\_available** – This Boolean flag shall specify, when set to ‘1’ that a Text Fragment is present in a Text Fragment Table in the service signaling channel. When the flag is set to ‘0,’ no Text Fragment is included in the service signaling channel for this content item.

**content\_security\_conditions\_indicator** – A 1-bit field that shall indicate, when set to ‘1,’ that content protection is applied to at least one of the files that constitute this content item. In Version 1 of this Standard, the `content_security_conditions_indicator` field shall be set to ‘0’.

**playback\_length\_included** – This Boolean flag shall indicate, when set to ‘1,’ that the `playback_length_in_seconds` field is present in this iteration of the “for” loop. Setting this flag to ‘0’ shall indicate the `playback_length_in_seconds` field is not present in this iteration of the “for” loop.

**playback\_delay\_included** — This Boolean flag shall indicate, when set to ‘1,’ that the `playback_delay` field is present in this iteration of the “for” loop. Setting this flag to ‘0’ shall indicate the `playback_delay` field is not present in this iteration of the “for” loop.

- expiration\_included** — This Boolean flag shall indicate, when set to ‘1,’ that the expiration field is present in this iteration of the “for” loop. Setting this flag to ‘0’ shall indicate the expiration field is not present in this iteration of the “for” loop.
- content\_size\_included** – This Boolean flag shall indicate, when set to ‘1,’ that the content\_size field is present in this iteration of the “for” loop. Setting this flag to ‘0’ shall indicate the content\_size field is not present in this iteration of the “for” loop.
- available\_on\_internet** – When this 1-bit field is set to ‘1’, it shall indicate that all the files that constitute this content item are available over an Internet connection. When this field is set to ‘0’, it shall convey no information about whether or not the files that constitute this content item are available over an Internet connection.
- available\_in\_broadcast** – When this 1-bit field is set to ‘1’, it shall indicate that all the files that constitute this content item are available in the broadcast stream, in a file delivery component of this NRT service. When this 1-bit field is set to ‘0’, it shall convey no information about whether or not the files that constitute this content item are available in the broadcast stream. For this version of this standard, this field shall always be set to ‘1’. Implementers should note, however, that this will not necessarily be true for future versions of this standard.
- playback\_length\_in\_seconds** – This 20-bit unsigned integer quantity shall specify the duration of playback of the content, in seconds. For content not intended to be presented on a timeline, the value zero shall be used. For content that includes audio or audio/video content, the playback\_length\_in\_seconds shall indicate the playback length of the audio or audio/video content.
- playback\_delay** – A 20-bit unsigned integer count of the number of seconds following reception of the first byte of the associated content the receiver shall wait before playback may start, while buffering the incoming stream. A value of zero shall indicate playback may commence immediately. When playback\_delay is not provided, the receiver is expected to retrieve the complete file or file set prior to playback.
- expiration** – This 32-bit unsigned integer shall represent the expiration time of the content, expressed as the number of GPS seconds since 00:00:00 UTC, 6 January 1980. Following expiration, the content should be deleted from memory. If an expiration time is not specified, receivers are expected to use methods of their own choosing to manage memory resources.
- content\_size** – When present, this 40-bit unsigned integer quantity shall represent the total size in bytes of the content item or items. This item is used by the receiving device to determine if enough memory is available to store it before downloading is attempted. The content\_size field shall be present when content\_size\_included is set to ‘1’ and absent otherwise. When content\_size is not present in a given iteration of the “for” loop, the size of the content described in that iteration shall be the value specified in the default\_content\_size field in the NRT\_service\_descriptor() in the SMT, if that field is present in the descriptor.
- content\_name\_length** – This 8-bit unsigned integer field shall specify the length (in bytes) of the content\_name\_text().
- content\_name\_text()** – This field shall specify the content item title in the format of a multiple string structure (see A/65 [13] Section 6.10).
- num\_content\_descriptors**– This 8-bit unsigned integer field shall indicate the total number of descriptors in the descriptor list that follows.

**content\_descriptor()** – One or more descriptors in standard MPEG-2 descriptor format (tag, length, data) may appear in this content item level descriptor loop to provide information about individual content items.

**num\_descriptors** – An 8-bit unsigned integer number that indicates the number of descriptors (if any) to follow.

**descriptor()** – Zero or more descriptors in standard MPEG-2 descriptor format (tag, length, data) may appear in this NRT-IT level descriptor loop to provide information common to all the NRT content described in this `NRT_information_table_section()`.

No descriptors are currently defined for the NRT-IT level descriptor loop. However, it is not forbidden for descriptors to appear there.

Table 6.4 below lists some content-level descriptors usable in the NRT-IT. The presence of some descriptors is mandatory, as indicated in the referenced sections where the descriptors are defined.

Other descriptors besides those in Table 6.4 may appear in the content item level descriptor loop.

**Table 6.4** Content-Level Descriptors in the NRT-IT

Descriptor Name	Descriptor Tag	Reference and Description
Time Slot Descriptor	0xC8	Section 8.7. Shall indicate the time(s) the associated content is scheduled to be made available in the digital transport.
Capabilities Descriptor	0xC5	Section 8.2. When present, shall list additional protocols (download protocols, FEC protocols, wrapper/archive protocols, compression protocols, and media formats), beyond those already listed in the service level Capabilities Descriptor, for which support is deemed essential to a meaningful presentation of this NRT content item, and may optionally list additional non-essential protocols used for this content item as well. (Contains indicators showing which protocols are essential and which are not.)
Internet Location Descriptor	0xC9	Section 8.8. When present, shall provide optional URLs for Internet-based access to file(s) in the content item.
Icon Descriptor	0xC6	Section 8.4. When present, shall provide the content-linkage (FDT file reference) for an icon that may be used to represent the NRT content item.
ISO-639 Language Descriptor	0x0A	Section 8.5. When present, shall indicate the language or languages of audio and/or textual components of the content item.
Content Labeling Descriptor	0x36	A/57 [11] and ISO/IEC 13818-1 [53] Section 2.6.56. When present, shall associate the content item with content labeling metadata. Use of ISAN in this descriptor is strongly recommended when the content item contains a single audio/video component.
Caption Service Descriptor	0x86	A/65[13] Section 6.9.2. When present, shall provide caption service information pertinent to the content item.
Content Advisory Descriptor	0x87	A/65 [13] Section 6.9.3. Only this descriptor, or its absence, shall determine the content advisory ratings for the content item.. Note: Implementers are advised that CFF files are permitted to have metadata fields to convey elements of rating data which should be ignored. Broadcasters should not attempt to populate these fields when creating content files.
Genre Descriptor	0xAB	A/65 [13] Section 6.9.13. When present, shall indicate one or more Genre categories associated with the content item.
Receiver Targeting Descriptor	0xC7	Section 9.2. When present, shall provide targeting criterion values to indicate the receivers to which the content item is targeted.
ATSC Private Information Descriptor	0xAD	A/53 Part 3 [3] Section 6.8.4. Usable for private information associated with the content item.

#### 6.4 Text Fragment Table (TFT)

The Text Fragment Table (TFT) contains text fragments used to provide detailed descriptions of content items or services. The TFT carries a data structure supporting multiple languages, and thus it may represent descriptions in several different languages (each string corresponding to one language).

There is a TFT for each NRT service. Each TFT consists of one or more TFT Instances, which are in a one-to-one correspondence with the NRT-IT Instances for the service.

The Text Fragment Table is carried in private sections with `table_id` value 0xE1, and it obeys the syntax and semantics given below. Each text fragment is distinguished by its unique 32-bit `TF_id`.

The TFT sections shall be carried in IP packets within the Service Signaling Channel, which has been assigned by IANA to multicast IP address 224.0.23.60, port 4937.

The following constraints apply to the IP packets carrying the TFT sections.

- There shall be no more than one TFT section in a single IP packet.
- Different TFT sections shall be in different IP packets.

Unless otherwise defined below, identically-named fields in the `text_fragment_table_section()` shall be as defined as in the `MH_service_signaling_table_section()` defined in A/153 Part 3 [7], Section 7.1. The bit stream syntax for the Text Fragment Table shall be as shown in Table 6.5.

**Table 6.5** Bit Stream Syntax for the Text Fragment Table

Syntax	No. Bits	Format
<code>text_fragment_table_section() {</code>		
<b>table_id</b>	8	0xE1
<b>section_syntax_indicator</b>	1	'0'
<b>private_indicator</b>	1	'1'
<b>reserved</b>	2	'11'
<b>section_length</b>	12	uimsbf
table_id_extension {		
<b>protocol_version</b>	8	uimsbf
<b>subnet_id</b>	8	uimsbf
}		
<b>reserved</b>	2	'11'
<b>TFT_version_number</b>	5	uimsbf
<b>current_next_indicator</b>	1	'1'
<b>section_number</b>	8	uimsbf
<b>last_section_number</b>	8	uimsbf
<b>service_id</b>	16	uimsbf
<b>time_span_start</b>	32	uimsbf
<b>reserved</b>	5	'11111'
<b>time_span_length</b>	11	uimsbf
<b>num_fragments_in_section</b>	8	uimsbf
for (j=0; j< num_fragments_in_section; j++) {		
<b>TF_id</b>	32	uimsbf
<b>text_length</b>	16	uimsbf
<b>text_fragment()</b>	var	
}		
}		

**table\_id** – This 8-bit field shall be set to 0xE1 to identify this table section as belonging to the Text Fragment Table.

**section\_length** – This 12-bit unsigned integer field shall specify the number of remaining bytes of this table section immediately following this field. The value in this field shall not exceed 4093 (0xFFD).

**protocol\_version** – This 8-bit unsigned integer field shall be set to 0x10, where the high order 4 bits indicate the major version number and the low order 4 bits indicate the minor version number. The function of `protocol_version` is to allow, in the future, this table type to carry parameters that may be structured differently than those defined in the current protocol. New values of `protocol_version` may be used by future versions of this standard to indicate structurally different tables.

**subnet\_id** – This 8-bit unsigned integer shall indicate the IP subnet associated with this service signaling channel.

**TF\_version\_number** – This 5-bit field shall indicate the version number of the entire TFT instance, where a TFT instance shall be identified as the value of the combination of `service_id`, `table_id`, `table_id_extension`, and `time_span_start` field values. The version number shall be incremented by 1 modulo 32 when any field in the TFT instance changes.

**current\_next\_indicator** – This 1-bit indicator shall always be set to ‘1’ for TFT sections; the TFT sent is always currently applicable.

**section\_number** – This 8-bit field shall give the section number of this TFT instance section, where the TFT instance is identified by the combination of `table_id`, `table_id_extension`, `service_id`, and `time_span_start` fields. The `section_number` of the first section in a TFT instance shall be 0x00. The `section_number` shall be incremented by 1 with each additional section in the TFT Table instance.

**last\_section\_number** – This 8-bit field shall give the number of the last section (i.e., the section with the highest `section_number`) of the TFT instance of which this section is a part.

**service\_id** — This 16-bit field shall specify the `service_id` associated with the service offering text fragments transported in this table section.

**time\_span\_start** – This 32-bit unsigned integer shall represent the start of the time span covered by this instance of the TFT, expressed as the number of GPS seconds since 00:00:00 UTC, 6 January 1980. The time of day of `time_span_start` shall be aligned to minute 00 of the hour. The value zero for `time_span_start` shall indicate the time period covered by his TFT instance began in the indefinite past. The value of `time_span_start` shall be the same for each section of a multi-sectioned TFT instance. The values of `time_span_start` and `time_span` length shall be set such that the specified time span does not overlap with any other TFT instance in this IP subnet. For Service Type 0x08 (NRT Services), `time_span_start` and `time_span_length` in a given TFT instance shall exactly align with equal values in the corresponding NRT-IT instance.

**time\_span\_length** – This 11-bit unsigned integer field in the range 0 to 1440 shall indicate the number of minutes, starting at the time indicated by `time_span_start`, covered by this instance of the TFT. Once established, the value of `time_span` length for a given value of `time_span_start` shall not change. A value of `time_span_length` of zero shall mean this TFT instance covers all time starting at `time_span_start` into the indefinite future. If the value of `time_span_start` is zero, `time_span_length` shall have no meaning. The value of `time_span_length` shall be the same for each section of a multi-sectioned TFT instance. The values of `time_span_start` and `time_span_length` shall be set such that the specified time span does not overlap with any other TFT instance in this IP subnet. For Service Type 0x08 (NRT Services), `time_span_start` and `time_span_length` in a given TFT instance shall exactly align with equal values in the corresponding NRT-IT instance.

**num\_fragments\_in\_section** – This 8-bit unsigned integer field shall indicate the number of text fragments described in this TFT section.

**TF\_id** – This 32-bit unsigned integer shall, when non-zero, uniquely identify a given text fragment in the context of the service identified by `service_id`. The `TF_id` value 0x00000000 shall indicate the text fragment describes the service identified by `service_id`. For services with `service_category` 0x0E (NRT Services), any value of `TF_id` other than 0x00000000 shall indicate that the text fragment describes the content item in the service with `content_linkage` value equal to `TF_id`.

**text\_length** – This 16-bit unsigned integer field shall indicate the length in bytes of the `text_fragment()` field to follow.

**text\_fragment()** – The text fragment in the format of a multiple string structure (see A/65 [13] Section 6.10).

## 6.5 Purchase Information Tables

This section specifies data structures to support the purchase of individual services, individual content items, and packages of services and/or content items. These data structures consist of two tables. The tables are:

- Purchase Item Table (PIT), each entry of which defines a purchase item consisting of one or more services and/or content items that can be purchased.
- Purchase Terms and Channels Table (PTCT) containing purchase terms entries, each of which defines a set of terms for a purchase (price and other terms), and purchase channel entries, each of which provides contact information for making a purchase.

These tables are both delivered in the Service Signaling Channel (SSC).

Each purchase item in the PIT references one or more purchase terms entries in the PTCT, specifying the possible sets of terms for purchasing that item.

Each purchase terms entry in the PTCT references a purchase channel entry in the PTCT, providing the contact information for making a purchase according to the terms in the purchase terms entry.

### 6.5.1 Purchase Item Table

There is one Purchase Item Table (PIT) instance for each IP subnet containing NRT services and/or content items which may be purchased or subscribed to. Each PIT is carried in private sections with `table_id` value 0xE5, and with syntax and semantics as defined below. The PIT sections shall be carried in IP multicast datagrams within the Service Signaling Channel for the subnet; i.e., IP multicast datagrams with multicast address 224.0.23.60 and port 4937. Each PIT instance may contain up to 256 sections.

The data structures in this section provide the basic metadata describing purchase items and the terms for purchase of such items, as well as descriptions of the "channels" (phone numbers and web site URLs) through which purchases can be made manually. A full system definition incorporating the ability to purchase services and content involves a number of aspects that are out of scope for the present Standard. Such aspects include (but are not limited to) specification of the process whereby the receiver accesses keys necessary to decrypt the content, required interfaces in the receiver to CA devices such as smartcards, and EMM and ECM stream signaling. ATSC A/70 [60] provides specifications for such aspects in the case of services. Other standards will be needed for the case of individual content items.

The following constraints apply to the IP multicast datagrams carrying the PIT sections:

- Each PIT section shall be in a single datagram.
- Different PIT sections shall be in different datagrams.

The syntax of the Purchase Item Table shall conform to the syntax shown in Table 6.6. Semantic definitions of the fields in the table appear below the table.

**Table 6.6** Syntax of Purchase Item Table

Syntax	No. Bits	Format
<code>purchase_item_table_section() {</code>		
<b>table_id</b>	8	0xE5
<b>section_syntax_indicator</b>	1	'0'
<b>private_indicator</b>	1	'1'
<b>reserved</b>	2	'11'
<b>section_length</b>	12	uimsbf
table_id_extension {		
<b>protocol_version</b>	8	uimsbf
<b>subnet_id</b>	8	uimsbf
}		
<b>reserved</b>	2	'11'
<b>version_number</b>	5	uimsbf
<b>current_next_indicator</b>	1	'1'
<b>section_number</b>	8	uimsbf
<b>last_section_number</b>	8	uimsbf
<b>default_item_time_span_start</b>	32	uimsbf
<b>default_item_time_span_end</b>	32	uimsbf
<b>num_purchase_items_in_section</b>	8	uimsbf
for (i=0; i< num_purchase_items_in_section; i++) {		
<b>purchase_item_id</b>	32	uimsbf
<b>closed_to_new_purchasers</b>	1	bslbf
<b>preview_data_included</b>	1	bslbf
<b>time_span_inherited</b>	1	bslbf
<b>reserved</b>	5	'11111'
<b>purchase_item_name_length</b>	8	uimsbf
<b>purchase_item_name_text()</b>	var	
<b>purchase_item_description_length</b>	8	uimsbf
<b>purchase_item_description_text()</b>	var	
if (preview_data_included)		
<b>preview_data_content_linkage</b>	32	uimsbf
if (time_span_inherited == 0) {		
<b>item_time_span_start</b>	32	uimsbf
<b>item_time_span_end</b>	32	uimsbf
}		
<b>num_purchase_item_id_refs</b>	8	uimsbf
for (j=0; j< num_purchase_item_id_refs; j++) {		
<b>purchase_item_id_ref</b>	32	uimsbf
}		
<b>num_services</b>	8	uimsbf
for (j=0; j< num_services; j++) {		
<b>service_id_ref</b>	16	uimsbf
<b>num_content_items</b>	8	uimsbf
for (k=0; k< num_content_items; k++) {		
<b>content_linkage</b>	32	uimsbf
}		
}		
}		



- default\_item\_time\_span\_end** – This 32-bit unsigned integer field shall be the default value for the `item_time_span_end` fields in the loop iterations following this field. It shall be interpreted as the number of GPS seconds since 00:00:00 UTC, 6 January 1980.
- num\_purchase\_items\_in\_section** – This 8-bit unsigned integer field shall be the number of purchase items described in this table section. This is also the number of iterations of the loop immediately below this field. Each iteration of the loop will be referred to as a “purchase item entry”.
- purchase\_item\_id** – This 32-bit unsigned integer field shall identify the purchase item described in this loop iteration. This value shall be unique among all purchase items in the PIT.
- closed\_to\_new\_purchasers** – This 1-bit indicator shall be set to ‘1’ if this purchase item is available only to those customers who have already purchased it (i.e., if it is no longer offered to new customers). This indicator shall be set to ‘0’ when this purchase item is available to new customers.
- preview\_data\_included** – This 1-bit indicator shall be set to ‘1’ when there is preview data available for this purchase item; otherwise it shall be set to ‘0’.
- time\_span\_inherited** – This 1-bit indicator shall be set to ‘1’ when the default time span values are valid for this purchase item. This indicator shall be set to ‘0’ when `time_span_start` and `time_span_end` values are defined in this loop iteration to override the default values.
- purchase\_item\_name\_length** – This 8-bit unsigned integer field shall give the length in bytes of the `purchase_item_name_text()` field.
- purchase\_item\_name\_text()** – This variable length field shall contain the name of this purchase item, using UTF-8 encoding.
- purchase\_item\_description\_length** – This 8-bit unsigned integer field shall give the length in bytes of the `purchase_item_description()` field.
- purchase\_item\_description\_text()** – This text string shall give a description of the pricing and terms information for the user, in the format of a multiple string structure (see A/65 [13] Section 6.10).
- preview\_data\_content\_linkage** – When present, this 32-bit unsigned integer field shall be the content linkage value for the FLUTE files that make up the preview data for this purchase item.
- item\_time\_span\_start** – When present, this 32-bit unsigned integer field shall give the start time of the interval of validity for the information about the purchase item that is contained in this loop iteration. It shall be interpreted as the number of GPS seconds since 00:00:00 UTC, 6 January 1980. The `default_item_time_span_start` field shall be used as the default value if this `time_span_start` field is not present.
- item\_time\_span\_end** – When present, this 32-bit unsigned integer field shall give the end time of the interval of validity for the information about the purchase item that is contained in this loop iteration. It shall be interpreted as the number of GPS seconds since 00:00:00 UTC, 6 January 1980. The `default_item_time_span_end` field shall be used as the default value if this `time_span_end` field is not present.
- num\_purchase\_item\_id\_refs** – This 8-bit unsigned integer field shall give the number of other purchase items that are included in this purchase item. It is the number of iterations of the loop immediately following this field.
- purchase\_item\_id\_ref** – This 32-bit unsigned integer field shall give the `purchase_id` value of another purchase item, indicating that it is included in the purchase item being described.

**num\_services** – This 8-bit unsigned integer field shall give the number of services in the loop immediately following this field.

**service\_id\_ref** – This 16-bit unsigned integer field shall give the `service_id` of an NRT service. The service may be in this broadcast stream, or it may be in a different broadcast stream. If the `num_content_items` field immediately following this field has value 0, that shall indicate that the service represented by this `service_id` is included in the purchase item being described. If the `num_content_items` field immediately following this field has a non-zero value, that shall indicate that the individual content items in the loop following the `num_content_items` field are included in the purchase item being described.

**num\_content\_items** – This 8-bit unsigned integer field shall give the number of content items that are listed in the loop immediately following this field.

**content\_linkage** – This 32-bit unsigned integer value shall match the value of the `content_linkage` field in the NRT-IT of a content item in the service represented by the `service_id_ref` field above, indicating that the content item is included in the purchase item being described.

**num\_purchase\_terms** – This 8-bit unsigned integer field shall give the number of `purchase_terms` entries that apply to this purchase item.

**purchase\_terms\_id\_ref** – This 16-bit unsigned integer field shall match the `purchase_terms_id` value of an entry in the Purchase Terms and Channels Table in this subnet, indicating that the referenced purchase terms apply to this purchase item.

**num\_dependency\_purchase\_refs** – This 8-bit unsigned integer field shall give the number of references to other purchase items on which this purchase item is dependent.

**dep\_purchase\_item\_id\_ref** – This 32-bit unsigned integer field shall match the `purchase_item_id` of another purchase item, with the meaning that one or more of the purchase items so identified must be purchased before the purchase item being described can be purchased.

**num\_exclusion\_purchase\_refs** – This 8-bit unsigned integer field shall give the number of references to other purchase items which are excluded by this purchase item.

**excl\_purchase\_item\_id\_ref** – This 32-bit unsigned integer field shall match the `purchase_item_id` of another purchase item, with the meaning that the referenced purchase item should not be offered after the user subscribes to this purchase item.

Note that in the case of a purchase item that contains other purchase items, such as a purchasable bundle containing individually purchasable services and/or content items, or a purchasable service containing individually purchasable content items, this “exclusion” field is not needed to indicate the exclusion relationship, since the receiver can deduce it from the known containment relationship. In such a situation this field can be omitted, to save bandwidth and avoid unnecessary updates to the purchase item.

**num\_purchase\_item\_descriptors** – This 8-bit unsigned integer field shall give the number of descriptors that appear in the descriptor loop immediately following this field.

**purchase\_item\_descriptor()** – This variable length field shall contain a descriptor providing additional information about the purchase item being described.

### 6.5.2 Purchase Terms and Channels Table

There is one Purchase Terms and Channels Table (PTCT) instance for each IP subnet containing NRT services and/or content items which may be purchased or subscribed to. Each PTCT is carried in private sections with `table_id` value 0xE6, and with syntax and semantics as defined below. The PTCT sections shall be carried in IP multicast datagrams within the Service

Signaling Channel for the subnet; i.e., IP multicast datagrams with multicast address 224.0.23.60 and port 4937. Each PTCT instance may contain up to 256 sections.

The following constraints apply to the IP multicast datagrams carrying the PTCT sections.

- Each PTCT section shall be in a single datagram.
- Different PTCT sections shall be in different datagrams.

The syntax of the Purchase Terms and Channels Table shall conform to the syntax shown in Table 6.7 below. Semantic definitions of the fields in the table appear below the table.

**Table 6.7** Syntax of Purchase Terms and Channels Table

Syntax	No. Bits	Format
<code>purchase_terms_and_channels_table_section() {</code>		
<b>table_id</b>	8	0xE6
<b>section_syntax_indicator</b>	1	'0'
<b>private_indicator</b>	1	'1'
<b>reserved</b>	2	'11'
<b>section_length</b>	12	uimsbf
<b>table_id_extension</b> {		
<b>protocol_version</b>	8	uimsbf
<b>subnet_id</b>	8	uimsbf
}		
<b>reserved</b>	2	'11'
<b>version_number</b>	5	uimsbf
<b>current_next_indicator</b>	1	'1'
<b>section_number</b>	8	uimsbf
<b>last_section_number</b>	8	uimsbf
<b>default_terms_time_span_start</b>	32	uimsbf
<b>default_terms_time_span_end</b>	32	uimsbf
<b>num_purchase_terms_in_section</b>	8	uimsbf
for (i=0; i< num_purchase_terms_in_section; i++) {		
<b>purchase_terms_id</b>	32	uimsbf
<b>time_span_inherited</b>	1	bslbf
<b>reserved</b>	3	'111'
<b>purchase_type</b>	4	uimsbf
if (time_span_inherited == 0) {		
<b>terms_time_span_start</b>	32	uimsbf
<b>terms_time_span_end</b>	32	uimsbf
}		
<b>purchase_channel_id_ref</b>	8	uimsbf
<b>terms_description_length</b>	8	uimsbf
<b>terms_description_text()</b>	var	
<b>price_info</b> {		
<b>monetary_price</b>	14	uimsbf
<b>currency_code</b>	10	uimsbf
}		
<b>subscription_period_length</b>	8	uimsbf
<b>subscription_period_text()</b>	var	
<b>num_purchase_terms_descriptors</b>	8	uimsbf
}		

for (j=0; j<num_purchase_terms_descriptors; j++) {		
<b>purchase_terms_descriptor()</b>	var	
}		
}		
<b>default_chan_time_span_start</b>	32	uimsbf
<b>default_chan_time_span_end</b>	32	uimsbf
<b>num_purchase_channels_in_section</b>	8	uimsbf
for (i=0; i< num_purchase_channels_in_section; i++) {		
<b>purchase_channel_id</b>	7	uimsbf
<b>time_span_inherited</b>	1	bslbf
if (time_span_inherited == 0) {		
<b>chan_time_span_start</b>	32	uimsbf
<b>chan_time_span_end</b>	32	uimsbf
}		
<b>contact_url_length</b>	8	uimsbf
<b>contact_url_text()</b>	var	
<b>contact_phone_text_length</b>	8	uimsbf
<b>contact_phone_text()</b>	var	
<b>num_purchase_channel_descriptors</b>	8	uimsbf
for (j=0; j<num_purchase_channel_descriptors; j++) {		
<b>purchase_channel_descriptor()</b>	var	
}		
}		

**table\_id** – This 8-bit field shall be set to 0xE6 to identify this table section as belonging to the Purchase Terms and Channels Table.

**protocol\_version** – The purpose of this 8-bit unsigned integer field is to allow, in the future, this Purchase Terms and Channels Table to be structured differently from the definition given here. For the table as defined in this version of this Standard, the value shall be 0x10, where the high order 4 bits indicate the major protocol number and the low order 4 bits indicate the minor protocol number. Non-zero values of protocol\_version may be used by future versions of this standard to indicate structurally different tables.

**subnet\_id** – This 8-bit unsigned integer shall indicate the IP subnet associated with this service signaling channel.

**version\_number** – This 5-bit field is the version number of the entire Purchase Terms and Channels Table (PTCT). A PTCT shall be identified by the combination of table\_id and table\_id\_extension. The version\_number shall be incremented by 1 modulo 32 when a change in the information carried within the PTCT occurs.

**current\_next\_indicator** – This 1-bit indicator shall always be set to ‘1’ for PTCT sections; the PTCT sent is always currently applicable.

**section\_number** – This 8-bit field shall give the section number of this PTCT section, where the PTCT is identified by the combination of table\_id and table\_id\_extension. The section\_number of the first section in a PTCT shall be 0x00. The section\_number shall be incremented by 1 with each additional section in the PTCT.

- last\_section\_number** – This 8-bit field shall give the number of the last section (i.e., the section with the highest section\_number) of the PTCT of which this section is a part.
- default\_terms\_time\_span\_start** – This 32-bit unsigned integer field shall be the default value for the terms\_time\_span\_start fields in the loop iterations following this field. It shall be interpreted as the number of GPS seconds since 00:00:00 UTC, 6 January 1980.
- default\_terms\_time\_span\_end** – This 32-bit unsigned integer field shall be the default value for the terms\_time\_span\_end fields in the loop iterations following this field. It shall be interpreted as the number of GPS seconds since 00:00:00 UTC, 6 January 1980.
- num\_purchase\_terms\_in\_section** – This 8-bit unsigned integer field shall be the number of purchase terms described in this table section. This is also the number of iterations of the loop immediately below this field. Each iteration of this loop will be referred to as a “purchase terms entry”.
- purchase\_terms\_id** – This 32-bit unsigned integer field shall identify the purchase terms described in this loop iteration. This value of purchase\_terms\_id shall be unique among all the values of purchase\_terms\_id that appear in the PTCT.
- time\_span\_inherited** – This 1-bit indicator shall be set to ‘1’ when the default terms time span values are valid for this purchase item. This indicator shall be set to ‘0’ when terms\_time\_span\_start and terms\_time\_span\_end values are defined in this loop iteration to override the default values.
- purchase\_type** – This 4-bit field shall represent the offered method for purchase of the referenced NRT purchase item. Possible values are:
- 0: One-time purchase: a one-time, “a-la carte” purchase of the NRT purchase item. The user will be charged for the amount indicated by monetary\_price.
  - 1: Recurring subscription: the nominal subscription period is given by the ‘subscription period’ string. The subscription will remain In effect until the user explicitly unsubscribes. The subscription\_period\_text() field indicates the nominal frequency at which the user will be charged for the amount specified by the monetary\_price.
  - 2: Free trial subscription: the subscription is intended to provide the user a one-time only, cost-free access to the referenced NRT service.
  - 3 – 15: These values are reserved for future use.
- terms\_time\_span\_start** – When present, this 32-bit unsigned integer field shall give the start time of the interval of validity for the information about the purchase terms that is contained in this loop iteration. It shall be interpreted as the number of GPS seconds since 00:00:00 UTC, 6 January 1980.
- terms\_time\_span\_end** – When present, this 32-bit unsigned integer field shall give the end time of the interval of validity for the information about the purchase terms that is contained in this loop iteration. It shall be interpreted as the number of GPS seconds since 00:00:00 UTC, 6 January 1980.
- purchase\_channel\_id\_ref** – This 8-bit unsigned integer shall identify the particular business entity or system associated with the purchase terms being described. Refer to the associated purchase channel for the URL and contact information for this purchase channel.
- purchase\_terms\_description\_length** – This 8-bit unsigned integer field shall give the length in bytes of the purchase\_terms\_description() field.

**purchase\_terms\_description\_text()** – This text string shall give a description of the pricing and terms information for the user, in the format of a multiple string structure (see A/65 [13] Section 6.10).

**monetary\_price** – This 14-bit field shall be the cost, in currency (see below), of the purchase.

**currency** – This 10-bit field shall encode the currency used to set the cost of the purchase. The currency is specified in 3-digit ISO 4217 [45] currency codes.

**subscription\_period\_length** – This 8-bit unsigned integer shall specify the length (in bytes) of the `subscription_period_text` field.

**subscription\_period\_text()** – This text string shall give the subscription period in the form of an XML Schema duration data type. Values such as P1M (one month), P1Y (one year), PT1H (one hour), and fractions thereof are possible.

**num\_purchase\_terms\_descriptors** – This 8-bit unsigned integer field shall give the number of descriptors in the descriptor loop immediately following this field.

**purchase\_terms\_descriptor()** – This variable length field shall contain a descriptor giving additional information about the purchase terms.

**default\_chan\_time\_span\_start** – This 32-bit unsigned integer field shall be the default value for the `chan_time_span_start` fields in the loop iterations following this field. It shall be interpreted as the number of GPS seconds since 00:00:00 UTC, January 6, 1980.

**default\_chan\_time\_span\_end** – This 32-bit unsigned integer field shall be the default value for the `chan_time_span_end` fields in the loop iterations following this field. It shall be interpreted as the number of GPS seconds since 00:00:00 UTC, 6 January 1980.

**num\_purchase\_channels\_in\_section** – This 8-bit unsigned integer field shall give the number of purchase channels described in the loop following this field. This is also the number of iterations of the loop immediately below this field. Each iteration of this loop will be referred to as a “purchase channel entry”.

**purchase\_channel\_id** – This 8-bit unsigned integer shall identify the particular business entity or system from which NRT purchase items can be acquired. It may also be used by the fixed NRT receiver to restrict purchasing choices to a pre-configured list of channel-choices in the receiver.

**chan\_time\_span\_start** – When present, this 32-bit unsigned integer field shall give the start time of the interval of validity for the information about the purchase channel that is contained in this loop iteration. It shall be interpreted as the number of GPS seconds since 00:00:00 UTC, 6 January 1980.

**chan\_time\_span\_end** – When present, this 32-bit unsigned integer field shall give the end time of the interval of validity for the information about the purchase channel that is contained in this loop iteration. It shall be interpreted as the number of GPS seconds since 00:00:00 UTC, 6 January 1980.

**channel\_url\_length** – This 8-bit unsigned integer field shall specify the length (in bytes) of the `channel_url_text()` character string.

**channel\_url\_text()** – This text string shall specify the URL used to perform purchase transactions.

**contact\_phone\_text\_length** – This 8-bit unsigned integer field shall specify the length in bytes of the `contact_phone_number()` numeric string(s).

**contact\_phone\_text()** – This numeric string shall specify the one or more telephone numbers the user may call to perform purchasing with a customer care agent.

**num\_purchase\_channel\_descriptors** – This 8-bit unsigned integer field shall give the number of descriptors in the descriptor loop immediately following this field.

**purchase\_channel\_descriptor()** – This variable length field shall contain a descriptor providing additional information about the purchase channel being described.

## 7. SIGNALING AND ANNOUNCEMENTS FOR MOBILE NRT BROADCASTS

The new data structures defined in this major section and its subsections are signaled by the presence of a Protocol Version Descriptor per section 8.1 with the `protocol_identifier` field set to 0x03, `major_protocol_version` field set to 0x01 and `minor_protocol_version` field set to 0x00. This combination associates the major version of data structures defined in A/153:2009 to those herein. This version signaling system is established to enable explicit signaling so that future changes can be made without impacting receivers that support earlier versions.

### 7.1 Signaling for Mobile NRT Broadcasts

#### 7.1.1 Overview

The Signaling subsystem provides the information necessary for a receiver to acquire and present the content of NRT services.

The signaling of ATSC mobile NRT services is based on the system used for signaling M/H services in general, namely the FIC/SMT hierarchy (Fast Information Channel and Service Map Table).

The use of the SMT for signaling ATSC mobile NRT services is nearly identical to its use for signaling ATSC fixed NRT services. However, in the mobile case, a broadcaster has the possibility of expressing some of the service-level information in the Announcement data used for the content guide (see Sections 7.1.4 and 7.2).

The FLUTE extensions used for ATSC mobile NRT services are exactly the same as those used for ATSC fixed NRT services.

This section gives an description of the overall TPC/FIC/SMT signaling hierarchy for M/H services, then specifies (a) how NRT services are signaled in the SMT, and (b) how to map files delivered via the FLUTE multicast file delivery protocol to corresponding Content fragments in the OMA BCAST Service Guide announcements.

#### 7.1.2 Background on ATSC-M/H Signaling

ATSC-M/H Signaling has a hierarchical structure in which two distinct steps must be followed for acquisition of the content comprising any M/H service, as specified in A/153 Part 3 [7].

- 1) M/H Ensemble access: The signaling through the Fast Information Channel (FIC) defined in Section 6.6 of A/153 Part 3 [7] provides the binding information between M/H Service identifiers and M/H Ensembles. It also provides some very high level information about each M/H Service.
- 2) IP level M/H Service access: The Service Map Table defined in Section 7.3 of A/153 Part 3 [7] provides for each Service: (a) information necessary to access the content of the Service, including IP addresses, UDP ports, and may include other parameters (b) information about media types and parameters necessary to decode and present the content of the Service, and (c) some other descriptive information about the Service.

Figure 7.1 illustrates this signaling hierarchy.

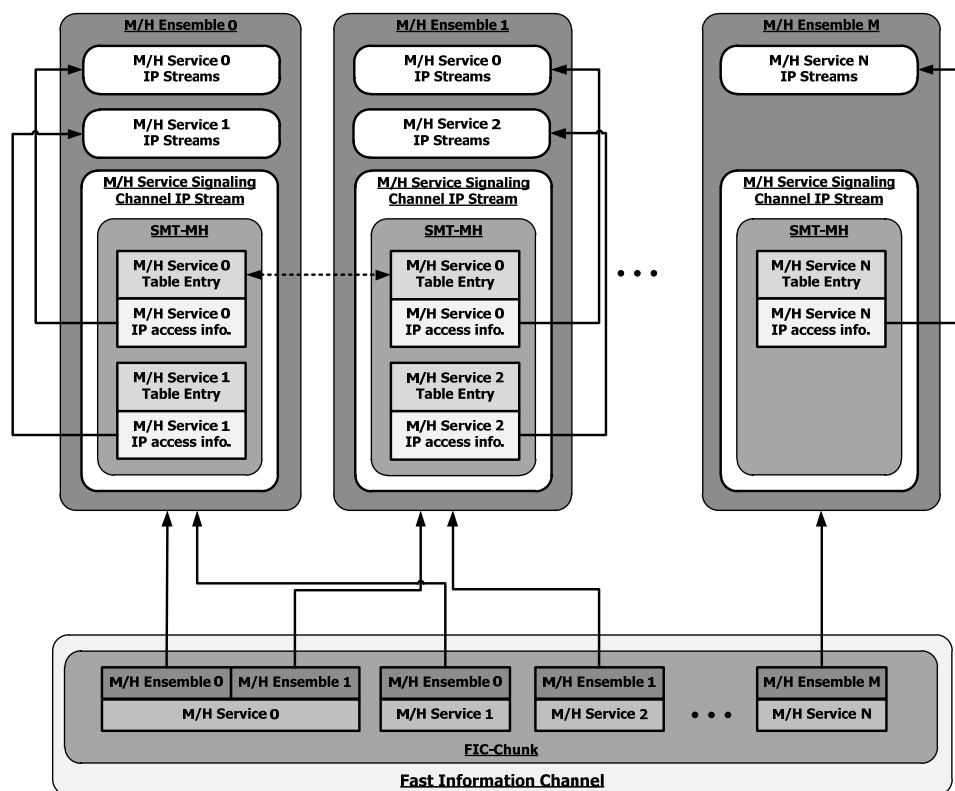

**Figure 7.1** ATSC-M/H Hierarchical Signaling Architecture.

An NRT service is a special case of an M/H service, so NRT services appear in the SMT along with the other services. They are distinguished from other, non-NRT services by the value of the associated `service_category` field in the SMT.

In the case of an NRT service delivering files via FLUTE sessions, the service information in the SMT includes not only IP addresses and UDP ports, but also Transport Session Identifiers (TSIs) of the FLUTE sessions and optionally bandwidths and FEC parameters for the sessions.

### 7.1.3 Signaling NRT Services in the Service Map Table

Non-Real-Time services in the mobile broadcast emission can be provided as standalone NRT services or as NRT adjunct components for other types of mobile broadcast services.

Standalone NRT services carry only file-based content, such as A/V clips, full-length video files, textual/graphics information, and the like. Each standalone mobile NRT service shall be signaled in an SMT-MH section with `SMT_MH_protocol_version = 0x00` in the ensemble containing the service. For such standalone NRT services, the `service_category` field shall be set to `0x0E`.

The `service_id` of a standalone mobile NRT service shall be assigned according to the rules given in Annex B of A/153 Part 3 [7], just as for any other type of mobile service.

NRT adjuncts may be present as components within other types of services (i.e., services with `service_category` value other than `0x0E`), or they may appear as separate NRT services (with `service_category` value `0x0E`) linked to the main service via an Associated Service Descriptor. (defined in Section 8.9 of this Standard.)

In order to avoid ambiguities in the signaling, an M/H service shall not contain NRT components of different major protocol versions. Moreover, an M/H service shall not contain NRT components along with other data services, such as file delivery of external resources to

support a streaming OMA RME application. If it is desired for a main service to have NRT adjuncts of different protocol versions or to have an NRT adjunct along with file delivery of external resources to support a streaming OMA RME application, then one or more of the NRT adjuncts will need to go in one or more separate services. In this case they shall be linked to the main service via an Associated Service Descriptor.

If NRT services are present in an ensemble, whether standalone or adjunct, and if they all have the same NRT protocol version, then a Protocol Version Descriptor (defined in Section 8.1 of this Standard) with `protocol_identifier` field set to 0x03 shall be present in the ensemble level descriptor loop of the SMT-MH (`ensemble_level_descriptor()` field), to indicate the common NRT protocol version of the NRT services. If NRT services are present in an ensemble, but they do not all have the same NRT protocol version, then a Protocol Version Descriptor with `protocol_identifier` field set to 0x03 shall be present in the service level descriptor loop (`service_level_descriptor()` field) for each standalone NRT service and each non-NRT service which contains NRT adjunct components, to indicate the NRT protocol version of the NRT service or NRT adjunct components.

Exactly one instance of an NRT Service Descriptor (defined in Section 8.2 of this Standard) shall be present in the service level descriptor loop in the SMT-MH for each standalone NRT service and for each non-NRT service in which adjunct NRT components are present.

One or more Capability Descriptor instances (defined in Section 8.3 of this Standard) shall be present in the service level descriptor loop in the SMT-MH for each standalone NRT service, and for each non-NRT service in which adjunct NRT components are present, to list the capabilities needed for a meaningful presentation of the NRT service or adjunct components.

Certain other tables may appear in the M/H Service Signaling Channel (SSC), as specified in A/153 Part 3 [7]. Receivers are expected to ignore any unknown structures found in the SSC.

#### 7.1.4 SMT-MH Descriptors

In order to provide the broadcaster with the flexibility to minimize the size of the SMT-MH, the following descriptors may be omitted from the SMT in the mobile case, and specified in equivalent form as part of the Announcement data:

- Icon Descriptor
- ISO-639 Language Descriptor
- Receiver Targeting Descriptor
- Genre Descriptor

Other descriptors are required as follows.

As specified above, a Protocol Version Descriptor with `protocol_identifier` value 0x03 is required in the ensemble level descriptor loop of the SMT-MH under certain circumstances.

As specified above, an NRT Service Descriptor and one or more Capability Descriptors are required in the service level descriptor loop of any NRT service or any non-NRT service that includes adjunct NRT components. Also, a Protocol Version Descriptor with `protocol_identifier` value 0x03 is required in the service level descriptor loop of such services under certain circumstances.

As specified above, an Associated Service Descriptor is required in the service level descriptor loop of any service that has associated adjunct NRT services.

The FLUTE sessions used to transmit files for NRT services or adjunct NRT components in non-NRT services shall be signaled with FLUTE component descriptors, as specified in A/153.

An NRT Service that employs the update channel usage described in Section 5.11.1 shall signal this usage with the extension to the FLUTE component descriptor defined in Section 8.6 of this standard.

The other properties of services that are described in descriptors for fixed NRT broadcasts should be described in the OMA BCASST Service Guide data structures for mobile broadcasts.

Other descriptors are not prohibited in the ensemble level, service level or component level descriptor loops.

#### 7.1.5 Mapping FLUTE Files to Content Elements in the Service Guide

Descriptions of the individual content items being delivered in a Mobile DTV NRT service are provided through Content fragments of the OMA BCASST Service Guide, as specified in Section 7.2 of this Standard. An NRT content item may be composed of one or more files being delivered via a FLUTE file delivery session. Each file may be a part of one or more content items. It is necessary to identify which files belong to which content items.

These requirements are met by introducing two new elements, 'FDTContentLinkage' and 'FileContentLinkage', into the XML schema for the FLUTE File Delivery Table (FDT), as defined in Section 5.3 of this Standard. The value of the 'ContentLinkage' element in the Service Guide Content fragment shall match the value of one of these elements for each file that is associated with the content item. The precedence rules for matching the value of the Service Guide 'ContentLinkage' element with the values of the 'FDTContentLinkage' and 'FileContentLinkage' elements are defined in Section 5.3. Each File described in the FLUTE FDT shall have a separate content linkage element for each content item with which it is associated.

For some types of content, it is also necessary to identify which file out of the group of files associated with a content item should be rendered or played back initially. This requirement is met through the 'entry' attribute of the 'FileContentLinkage' element in the FLUTE FDT. The use of the 'entry' attribute of 'FileContentLinkage' element is described in Section 5.3.

## 7.2 Announcement for Mobile NRT Broadcasts

### 7.2.1 Overview

The Announcement subsystem is used to announce information regarding the NRT services and content available on a given ATSC system. The information available through the Announcement subsystem provides receivers with a robust description of the available services and content, as well as the schedule information and access parameters necessary to receive the services and content.

### 7.2.2 Relationship to Mobile NRT Signaling

There is some overlap between the metadata delivered through signaling and via the Announcement subsystem. To the extent possible, metadata items between which there is a semantic mapping should be consistent between the two sources within a transmission, and updates should be synchronized.

However, a receiver may not acquire both metadata sources simultaneously even in a self-consistent transmission. Where metadata regarding NRT services or content delivered via the Announcement subsystem differs from that delivered through signaling, and there exists a defined semantic mapping between the two metadata items, the metadata delivered through signaling shall take precedence.

When any metadata element describing NRT services or content is present in signaling, it shall take precedence over any data present in or absent from the announcement of the corresponding services or content. The process to use for matching of metadata terms for which there is not a defined semantic mapping is undefined.

### 7.2.3 Approach for Announcing Mobile NRT Services and Content

Mobile NRT services and content shall be announced through the ATSC-M/H Announcement subsystem using a service guide, as described in A/153 Part 4 [8], with constraints and extensions for NRT services as specified in this Standard.

Mobile NRT services and content may be described in an instance of the service guide which also describes other services available via ATSC-M/H (e.g., linear audio and video) or they may be described in an entirely separate service guide instance.

### 7.2.4 ATSC Mobile NRT Service Guide Data Model

This Section defines a set of constraints and extensions to the ATSC-M/H Service Guide Data Model defined in Section 6 of A/153 Part 4 [8] for use in announcement of NRT services and content. (The A/153 data model is itself a constrained subset of the data model specified in the OMA BCASST Service Guide specification, Version 1.0 [56].)

Service guide fragments used to announce information regarding NRT services and content shall conform to the data model described in this standard, which extends the A/153 data model (and XML schema) in three distinct ways.

- The allowed values for existing A/153 data model elements are modified or constrained compared to A/153. These changes are intended to be consistent with the OMA BCASST SG XML schema.
- Additional data model elements from the OMA BCASST SG namespace that are not specified in A/153 are employed. Additional data model elements not defined in the OMA BCASST SG are introduced. Some are defined within the PrivateExt elements provided for such extensions in the OMA BCASST schema and specified for this purpose in A/153. Others are defined as extensions to non-A/153 OMA elements, at otherextensibility points defined within the OMA BCASST SG schema.

A guide that includes mobile NRT services guide is a collection of XML fragments whose syntax is described by A/153 and/or OMA BCASST SG (using the OMA BCASST XML namespace), together with additional XML elements defined by this standard (using the ATSC NRT namespace defined in Section 3.6).

Note: The following conventions apply to all tables in this Section:

- Metadata items which are represented as XML elements are shown in plain text.
- Metadata items which are represented as XML attributes are shown in *italics*.
- Extensions/constraints to the allowed values of A/153 data model elements are shown with a border.
- Additions to the data model specified in A/153 that make use of existing OMA BCASST data model elements are highlighted in light gray.
- Additions to the data model specified in OMA BCASST (and therefore making use of the ATSC NRT namespace) are **highlighted in light gray and bold**.

## 7.2.4.1 Service Fragment

Use of the Service fragment of the service guide shall conform to the specifications in Section 6.1 of A/153 Part 4 [8] with extensions for NRT services as shown in Table 7.1.

**Table 7.1** Service Fragment

---

Service
<i>id</i>
<i>version</i>
<i>validFrom</i>
<i>validTo</i>
<i>globalServiceID</i>
<i>weight</i>
<i>baseCID</i>
ServiceType
Name
Description
AudioLanguage
<i>languageSDPtag</i>
TextLanguage
<i>languageSDPtag</i>
ParentalRating
<i>ratingSystem</i>
<i>ratingValueName</i>
TargetUserProfile
Genre
Extension
<i>url</i>
Description
PreviewDataReference
<i>idRef</i>
<i>usage</i>
BroadcastArea
PrivateExt
<b>ServicePrivateExt</b>
<b>ConsumptionModel</b>
<b>EssentialCapabilities</b>
<b>CapabilityCodes</b>
<b>CapabilityString</b>
<i>category</i>
<b>CapabilityOrGroup</b>
<b>CapabilityCodes</b>
<b>CapabilityString</b>
<i>category</i>
<b>NonessentialCapabilities</b>
<b>CapabilityCodes</b>
<b>CapabilityString</b>
<i>category</i>

---

---

<b>CapabilityOrGroup</b>
<b>CapabilityCodes</b>
<b>CapabilityString</b>
<i>category</i>
<b>RequiredStorage</b>
<b>AutoUpdate</b>
<b>ContentDefaults</b>
<b>RequiredStorage</b>
<b>UpdatesAvailable</b>
<b>AcquisitionTime</b>
<b>InternetLocations</b>
<i>all</i>
<b>AssociatedServiceReference</b>
<i>idRef</i>

---

The following adaptations and extensions apply in addition to those described in Section 6.1 of A/153 Part 4 [8].

#### 7.2.4.1.1 Service Type

The *ServiceType* element values are extended to include a proprietary ATSC NRT type:

- A *ServiceType* element shall be included with value 129 to indicate that the Service fragment contains information regarding an ATSC NRT service.
- In the case of an adjunct NRT service, this element shall be included in addition to the *ServiceType* element specifying the main service type(s).

#### 7.2.4.1.2 Receiver Targeting

A specific usage of the OMA BCAST SG *TargetUserProfile* element is employed to optionally associate a service with a particular user profile. The detailed syntax and semantics of this element are described in Section 9.3.

A specific usage of the OMA BCAST SG *BroadcastArea* element is employed to optionally associate a service with a particular geographic location. The detailed syntax and semantics of this element are described in Section 9.3.

#### 7.2.4.1.3 SMT-Related Private Extensions

Elements from the ATSC NRT namespace may be used within the OMA *PrivateExt* element, to indicate SMT-related attributes, as listed in Table 7.2. As these parameters must be indicated in the NRT Service Descriptor and the Capabilities Descriptor in the SMT, it is redundant and hence optional to transmit them.

**Table 7.2 SMT-Related Private Extensions**

Name	Type	Category	Cardinality	Description	Data Type
ConsumptionModel	E2	NO/TO	0..1	NRT consumption mode. Value from Table 8.6. Required.	unsignedByte
AutoUpdate	E2	NO/TO	0..1	Whether to offer the user the option to auto-update content items.	boolean
RequiredStorage	E2	NO/TO	0..1	Total storage a receiver is expected to allocate to present the service, in kilobytes.	unsignedInt
Essential Capabilities	E2	NO/TO	0..1	Capabilities essential for a meaningful presentation of the service. Contains the following elements: CapabilityCodes CapabilityString CapabilityOrGroup	
CapabilityCodes	E3	NO/TO	0..1	A list of code points from Table A.1 in numeric form. See <code>capability_code</code> (Section 8.3).	list of unsignedByte
CapabilityString	E3	NO/TO	1..N	A string containing the representation of a capability per Table 8.8 and the text following it. See <code>capability_string</code> (Section 8.3). Contains the following attribute: <code>category</code>	string
category	A	NO/TO	1..1	Gives the capability category of the capability represented by this <code>CapabilityString</code> element.	unsignedByte
CapabilityOrGroup	E3	NO/TO	0..N	Group of capability codes and/or strings that are combined by "OR" logic to represent a single capability (i.e., a receiver satisfies the capability represented by the <code>CapabilityOrGroup</code> if it satisfies at least one of the capabilities in the group.)	
CapabilityCodes	E4	NO/TO	0..1	A list of capability code points from Table A.1 in numeric form. See <code>capability_code</code> (Section 8.3).	list of unsignedByte
CapabilityString	E4	NO/TO	1..N	A string containing the representation of a capability per Table 8.8 and the text following it. See <code>capability_string</code> (Section 8.3). Contains the following attribute: <code>category</code>	string

Name	Type	Category	Cardinality	Description	Data Type
category	A	NO/TO	1..1	Gives the capability category of the capability represented by this CapabilityString element.	unsignedByte
NonEssentialCapabilities	E2	NO/TO	0..1	Capabilities relevant to presenting the service, but not essential for a meaningful presentation. Contains the following elements: CapabilityCodes CapabilityString CapabilityOrGroup	
CapabilityCodes	E3	NO/TO	0..1	A list of code points from Table A.1 in numeric form. See capability_code (Section 8.3).	list of unsignedByte
CapabilityString	E3	NO/TO	1..N	A string containing the representation of a capability per Table 8.8 and the text following it. See capability_string (Section 8.3). Contains the following attribute: category	string
category	A	NO/TO	1..1	Gives the capability category of the capability represented by this CapabilityString element.	unsignedByte
CapabilityOrGroup	E3	NO/TO	0..N	Group of capability codes and/or strings that are combined by "OR" logic to represent a single capability (i.e., a receiver satisfies the capability represented by the CapabilityOrGroup if it satisfies at least one of the capabilities in the group.)	
CapabilityCodes	E4	NO/TO	0..1	A list of capability code points from Table A.1 in numeric form. See capability_code (Section 8.3).	list of unsignedByte
CapabilityString	E4	NO/TO	1..N	A string containing the representation of a capability per Table 8.8 and the text following it. See capability_string (Section 8.3). Contains the following attribute: category	string
category	A	NO/TO	1..1	Gives the capability category of the capability represented by this CapabilityString element.	unsignedByte

The optional *ConsumptionModel* element provides the mode in which the broadcaster expects the receiver to process the transmitted content within the NRT service. This element is the analogue of the SMT NRT Service Descriptor consumption\_model field (Section 8.2).

The optional *AutoUpdate* element indicates whether the option to auto-update the content within the service (in the fashion of an RSS feed) should be offered to the user. This element is the analogue of SMT NRT Service Descriptor auto-update (Section 8.2).

The optional *RequiredStorage* element provides an estimate of the storage required for all the files that make up a content item, including any future updates. This element is the analogue of SMT NRT Service Descriptor *storage\_reservation* (Section 8.2).

The optional *Capabilities* element provides the same information as the SMT Capabilities Descriptor in the fixed case, and it is subject to the same constraints with respect to values and usage at content item level as described in Section 8.3.

#### 7.2.4.1.4 ContentDefaults

An ATSC NRT namespace extension may be used to provide, for convenience and compactness reasons, default values for certain of the content-level elements defined in Sections 7.2.4.2 and 7.2.4.3. For the details of the data model and of the overriding semantics, see the descriptions in the appropriate sections.

**Table 7.3** Content Defaults

Name	Type	Category	Cardinality	Description	Data Type
ContentDefaults	E2	NO/TM	0..1	Default values for the corresponding content-level elements, which will supersede these values if present. Contains the following elements: RequiredStorage UpdatesAvailable AcquisitionTime InternetLocations	
RequiredStorage	E3	NO/TM	0..1	Default value for Content RequiredStorage value (in kilobytes)	unsignedInt
UpdatesAvailable	E3	NO/TM	0..1	Default value for Content UpdatesAvailable value	boolean
AcquisitionTime	E3	NO/TM	0..1	Default value for Schedule DistributionWindow duration value (in seconds)	unsignedInt
InternetLocations	E3	NO/TO	0..1	Default value for Content InternetLocations value. Contains the following attribute: all	list of anyUri
all	A	NO/TM	0..1	Indication whether all files are available on the internet. Default: false	boolean

#### 7.2.4.1.5 Associated Services

An *AssociatedServiceReference* element from the ATSC NRT namespace may be used within the OMA *PrivateExt* element to indicate that an M/H service has an adjunct NRT service.

**Table 7.4** Associated Services

Name	Type	Category	Cardinality	Description	Data Type
AssociatedServiceReference	E2	NO/TM	0..N	Reference to the Service fragment of an adjunct NRT service. Contains the following attribute: idRef	
idRef	A	NO/TM	1	Identification ( <i>id</i> attribute) of the associated NRT Service fragment.	anyUri

There may be multiple instances of this element for a given M/H service if an M/H service has several adjunct NRT services. An NRT service may also be an adjunct to multiple M/H

services, in which case there will be multiple *AssociatedServiceReference* elements that point to the same Service fragment of NRT type.

#### 7.2.4.2 Schedule Fragment

Use of the Schedule fragment of the service guide shall conform to the specifications in Section 6.2 of A/153 Part 4 [8], with extensions for NRT services using existing OMA BCASST elements as shown in Table 7.5.

**Table 7.5** Schedule Fragment

Schedule
<i>id</i>
<i>version</i>
<i>defaultSchedule</i>
<i>onDemand</i>
<i>validFrom</i>
<i>validTo</i>
ServiceReference
<i>idRef</i>
ContentReference
<i>idRef</i>
<i>contentLocation</i>
DistributionWindow
<i>startTime</i>
<i>endTime</i>
<i>duration</i>
PresentationWindow
<i>startTime</i>
<i>endTime</i>
<i>duration</i>
PrivateExt

The following adaptations and extensions apply in addition to those described in Section 6.3 of A/153 Part 4 [8].

##### 7.2.4.2.1 Distribution Window

The definition of *DistributionWindow* elements in a Schedule fragment associated with an ATSC NRT service shall be as specified in Table 7.6. Note that these entries and associated meaning are similar, but not identical, to the Cachecast services as specified in the OMA BCASST Service Guide [56], Section 5.1.2.2.

**Table 7.6** Distribution Window

Name	Type	Category	Cardinality	Description	Data Type
DistributionWindow	E2	NM/ TM	0..N	Time interval in which the referenced content specified by ContentID is available for delivery. Contains the following attributes: startTime endTime duration	
startTime	A	NO/ TM	0..1	Start of DistributionWindow. If not given, the validity is assumed to have begun at some time in the past. This field contains the 32bits integer part of an NTP time stamp.	unsignedInt
endTime	A	NO/ TM	0..1	End of DistributionWindow. If not given, the validity is assumed to end in undefined time in the future. This field contains the 32bits integer part of an NTP time stamp.	unsignedInt
duration	A	NO/ TM	0..1	The maximum amount of time that a terminal that begins to acquire the Content item during this DistributionWindow should allow to complete the acquisition. The unit of time is in seconds.	unsignedInt

Note: A set of *DistributionWindow* elements corresponds to some of the information provided in the fixed NRT case by the NRT-IT and its descriptors.

- The *startTime* and *endTime* of one or more *DistributionWindow* elements is equivalent to the Time Slot Descriptor, except that any repetition must be expressed explicitly. Note that the definition above is consistent with the OMA BCAST SG, in that it assumes that the transmission continues sufficiently far past *endTime* to ensure that a receiver that begins to listen at *endTime* should be able to acquire the content item.
- The *duration* of a *DistributionWindow* element is equivalent to the *acquisition\_time* field in the NRT-IT. If this attribute is not present, but an AcquisitionTime element is present as part of a *ContentDefaults* element in the Service fragment, the value of that element is used. Otherwise the expected acquisition time is undefined.

#### 7.2.4.2.2 Presentation Window

As constrained in A/153 Part 4 [8], and not altered herein, at most one instance of PresentationWindow element is allowed to be instantiated per ContentReference element instance. The *duration* attribute defined in the OMA BCAST Service Guide [56] Section 5.1.2.2 may also be used. The definition of *PresentationWindow* elements in a Schedule fragment associated with an ATSC NRT service shall be as specified in Table 7.7. Note that these entries and the associated meaning are similar, but not identical, to that of Cachecast services as specified in the OMA BCAST SG [56] Section 5.1.2.2.

**Table 7.7** Presentation Window

Name	Type	Category	Cardinality	Description	Data Type
PresentationWindow	E2	NM/ TM	0..1	Time interval in which the referenced content specified by ContentID is available for rendering. Contains the following attributes: startTime endTime duration	
startTime	A	NM/ TM	0..1	Start of PresentationWindow. If not given the validity is assumed to have begun at some time in the past. The earliest instant at which rendering of the associated content item can begin. This field contains the 32bits integer part of an NTP time stamp.	unsignedInt
endTime	A	NM/ TM	0..1	End of PresentationWindow. If not given, the validity is assumed to end in undefined time in the future. The latest instant at which the rendering of the associated content item can begin. This field contains the 32bits integer part of an NTP time stamp.	unsignedInt
duration	A	NO/TO	0..1	Time duration of the referenced content for rendering, in seconds.	unsignedInt

Note: A *PresentationWindow* element corresponds to some of the information provided in the fixed NRT case by the NRT-IT and its descriptors.

- The *endTime* attribute of the *PresentationWindow* element is equivalent to the expiration field in the NRT-IT.
- The *duration* attribute of the *PresentationWindow* element is equivalent to the *playback\_length\_in\_seconds* field in the NRT-IT.

#### 7.2.4.3 Content Fragment

Use of the Content fragment of the service guide shall conform to the specifications in Section 6.3 of A/153 Part 4 [8] with extensions for NRT services as shown in Table 7.8. In the case of an ATSC NRT service, a Content fragment corresponds to a content item that is potentially composed of multiple transported files. The semantics of the service guide closely match the OMA BCAST Cachecast service case, with the appropriate generalization to a file collection.

**Table 7.8** Content Fragment

Content
<i>id</i>
<i>version</i>
<i>validFrom</i>
<i>validTo</i>
<i>globalContentID</i>
<i>baseCID</i>
ServiceReference
<i>idRef</i>
<i>weight</i>
Name
Description
StartTime
EndTime
AudioLanguage
<i>languageSDPTag</i>
TextLanguage
<i>languageSDPTag</i>
Length
ParentalRating
<i>ratingSystem</i>
<i>ratingValueName</i>
TargetUserProfile
Genre
Extension
<i>url</i>
Description
PreviewDataReference
<i>idRef</i>
<i>usage</i>
BroadcastArea
PrivateExt
<b>ContentPrivateExt</b>
<b>ContentLinkage</b>
<b>EssentialCapabilities</b>
<b>CapabilityCodes</b>
<b>CapabilityString</b>
<i>category</i>
<b>CapabilityOrGroup</b>
<b>CapabilityCodes</b>
<b>CapabilityString</b>
<i>category</i>
<b>NonessentialCapabilities</b>
<b>CapabilityCodes</b>
<b>CapabilityString</b>
<i>category</i>
<b>CapabilityOrGroup</b>

<b>CapabilityCodes</b>
<b>CapabilityString</b>
<i>category</i>
<b>RequiredStorage</b>
<b>UpdatesAvailable</b>
<b>InternetLocations</b>
<i>all</i>
<b>PlaybackDelay</b>

The following adaptations and extensions apply in addition to those described in Section 6.1 of A/153 Part 4 [8].

#### 7.2.4.3.1 Receiver Targeting

A specific usage of the OMA BCAST SG *TargetUserProfile* element is employed to optionally associate a content item with a particular user profile. The detailed syntax and semantics of this element are described in Section 9.3.

A specific usage of the OMA BCAST SG *BroadcastArea* element is employed to optionally associate a content item with a particular geographic location. The detailed syntax and semantics of this element are described in Section 9.3.

#### 7.2.4.3.2 Content-Level Private Extensions

Elements from the ATSC NRT namespace are used within the OMA *PrivateExt* element, to indicate content-level attributes, as listed below.

**Table 7.9** Content-Level Private Extensions

Name	Type	Category	Cardinality	Description	Data Type
ContentLinkage	E2	NM/TM	1	ID of this content item, used to map files to content items.	unsignedInt
Essential Capabilities	E2	NO/TO	0..1	Capabilities essential for a meaningful presentation of the content item. Contains the following elements: CapabilityCodes CapabilityString CapabilityOrGroup	
CapabilityCodes	E3	NO/TO	0..1	A list of code points from Table A.1 in numeric form. See <code>capability_code</code> (Section 8.3).	list of unsignedByte
CapabilityString	E3	NO/TO	1..N	A string containing the representation of a capability per Table 8.8 and the text following it. See <code>capability_string</code> (Section 8.3). Contains the following attribute: category	string
category	A	NO/TO	1..1	Gives the capability category of the capability represented by this <code>CapabilityString</code> element.	unsignedByte
CapabilityOrGroup	E3	NO/TO	0..N	Group of capability codes and/or strings that are combined by “OR” logic to represent a single capability (i.e., a receiver satisfies the capability represented by the <code>CapabilityOrGroup</code> if it satisfies at least one of the capabilities in the group.)	
CapabilityCodes	E4	NO/TO	0..1	A list of capability code points from Table A.1 in numeric form. See <code>capability_code</code> (Section 8.3).	list of unsignedByte
CapabilityString	E4	NO/TO	1..N	A string containing the representation of a capability per Table 8.8 and the text following it. See <code>capability_string</code> (Section 8.3). Contains the following attribute: category	string
category	A	NO/TO	1..1	Gives the capability category of the capability represented by this <code>CapabilityString</code> element.	unsignedByte
Nonessential Capabilities	E2	NO/TO	1..N	Capabilities relevant to presenting the content item, but not essential for a meaningful presentation. Contains the following elements: CapabilityCodes CapabilityString CapabilityOrGroup	
CapabilityCodes	E3	NO/TO	0..1	A list of capability code points from Table A.1, in numeric form. See <code>capability_code</code> (Section 8.3).	list of unsignedByte
CapabilityString	E3	NO/TO	1..N	A string containing the representation of a capability per Table 8.8 and the text following it. See <code>capability_string</code> (Section 8.3). Contains the following attribute: category	string
category	A	NO/TO	1..1	Gives the capability category of the capability represented by this <code>CapabilityString</code> element.	unsignedByte
CapabilityOrGroup	E3	NO/TO	0..N	Group of capability codes and/or strings that are combined by “OR” logic to represent a single capability (i.e., a receiver satisfies the capability represented by the <code>CapabilityOrGroup</code> if it satisfies at least one of the capabilities in the group.)	

Name	Type	Cat egory	Cardin ality	Description	Data Type
CapabilityCodes	E4	NO/TO	0..1	A list of capability code points from Table A.1, in decimal form. See <i>capability_code</i> (Section 8.3).	list of unsignedByte
CapabilityString	E4	NO/TO	1..N	A string containing the representation of a capability as specified in Table 8.8 and the text following it. See <i>capability_string</i> (Section 8.3). Contains the following attribute: category	string
category	A	NO/TO	1..1	Gives the capability category of the capability represented by the <i>CapabilityString</i> element.	unsignedByte
RequiredStorage	E2	NM/TM	0..1	Storage required for the content item, in kilobytes.	unsignedInt
UpdatesAvailable	E2	NM/TM	0..1	Flag to indicate whether updates will be provided for this content item.	boolean
InternetLocations	E2	NO/TO	0..1	Content-locations of files within this content item that are available over the internet. Contains the following attribute: All	list of anyUri
all	A	NO/TM	0..1	Indication whether all files in the content item are available on the internet. Default: false	boolean
PlaybackDelay	E2	NO/TO	0..1	Playback delay in seconds for a progressive download content item. Maximum value is 1048575	unsignedInt

The *ContentLinkage* element shall be instantiated for each Content fragment in the Service Guide. Its value links the content description published through the service guide with the associated file or files carried on the FLUTE file delivery session for the NRT service. Each file associated with the content item represented by the Content fragment shall have a FLUTE FDT content linkage tag matching the value of the *ContentLinkage* element (where “content linkage tag” is defined in Section 5.3.) The value of the *ContentLinkage* element shall be set to an unsigned integer which is unique within the associated NRT service for the period of time beginning when the content item is first advertised through the service guide or any of its files appear in FLUTE FDT instances, and ending when the content item no longer appears in the guide and none of its files appear in FLUTE FDT instances (taking into account the “Expires” attribute of the FLUTE FDT instances). This element is the analogue of NRT-IT *content\_linkage* (Section 6.3) for the fixed case.

The *Capabilities* element provides the same information as the Capabilities Descriptor in the fixed case, and it is subject to the same constraints with respect to values and usage at service and content item level as described in Section 8.3.

The optional *RequiredStorage* element provides an estimate of the storage required for all the files that make up a content item, including any future updates. This element is the analogue of NRT-IT *content\_size* (Section 6.3) for the fixed case. If this element is absent at the content level but is provided in a *ContentDefaults* element at the service level, that value shall apply. If absent at both levels, the required storage is undefined.

The optional *UpdatesAvailable* element specifies whether the content item will be updated periodically. If so, receiving devices are expected to monitor for changes the TOI associated with each file associated with the content item’s content linkage value. If not, updates are not expected to be provided for the associated content item(s), and receivers are not expected to look for them. This element is the analogue of NRT-IT *updates\_available* (Section 6.3) for the fixed

case. If this element is absent but is provided in a *ContentDefaults* element at the service level, that value shall apply. If absent at both levels, the default value is false.

The optional *InternetLocations* element provides a list of URLs corresponding to files that are part of the content item and are available via the internet as well as via the broadcast. Each URL must be the Content-Location of a file described in the FDT for the FLUTE session delivering the content item. See the discussion in Section 5.9. If the attribute *all* has the value “true” (default: false), the element indicates that all files in a content item are available via the internet using the Content-Location from the FDT, and the element shall be empty. This element is the analogue of the Internet Location Descriptor and the *available\_on\_internet* indicator used in the NRT-IT (Section 8.8) for the fixed case. If this element is absent but is provided in a *ContentDefaults* element at the service level, that value shall apply (the only practically useful value in this case is with *all*=“true”). An element with *all*=“false” (or the attribute omitted) may be used to override for a specific content item a service level default that all files are available. If absent at both levels, no files are indicated as available via the Internet.

The optional *PlaybackDelay* element provides the number of seconds following reception of the first byte of any file in the associated content the receiver shall wait before rendering may start, while buffering the incoming FLUTE stream(s). A value of zero shall indicate playback may commence immediately. When the *PlaybackDelay* element is absent, the receiver is expected to retrieve the complete content item prior to rendering. This element is the analogue of NRT-IT *playback\_delay* (Section 6.3) for the fixed case.

#### 7.2.4.4 Access Fragment

Use of the Access fragment of the service guide shall conform to the specifications in Section 6.4 of A/153 Part 4 [8], with the addition of the option to instantiate the *PreviewDataReference* element as defined by OMA BCAST SG [56] for the Access fragment.

#### 7.2.4.5 Session Description Fragment

Use of the Session Description fragment of the service guide shall conform to the specifications in Section 6.5 of A/153 Part 4 [8].

#### 7.2.4.6 Purchase Metadata for M/H

The data structures in this section provide the basic metadata describing purchase items and the terms for purchase of such items, as well as descriptions of the “channels” (phone numbers and web site URLs) through which purchases can be made manually. A full system definition incorporating the ability to purchase services and content involves a number of aspects that are out of scope for the present standard. Such aspects include (but are not limited to) specification of the receiver components that acquire and manage security keys necessary to decrypt the content, and LTKM and STKM delivery. A/153 Part 6 [59] provides specifications for such aspects.

##### 7.2.4.6.1 Purchase Item Fragment

Use of the Purchase Item fragment of the service guide shall conform to the specifications in Section 6.6 of A/153 Part 4 [8], with the following changes:

- 1) E1 element ‘*PurchaseItemReference*’ is added, exactly as it is specified in the OMA BCAST v1.0 Service Guide [56] Section 5.1.2.6.
- 2) E1 element ‘*DependencyReference*’ is added, exactly as it is specified in the OMA BCAST v1.0 Service Guide [56] Section 5.1.2.6.

- 3) E1 element 'ExclusionReference' is added, exactly as it is specified in the OMA BCAST v1.0 Service Guide [56] Section 5.1.2.6.
- 4) Top-level attribute 'closed' is added, exactly as it is specified in the OMA BCAST v1.0 Service Guide [56] Section 5.1.2.6.

The revised data structure of the Purchase Item fragment is shown in Table 7.10 (added parameters are highlighted).

**Table 7.10** PurchaseItem Fragment

PurchaseItem
<i>id</i>
<i>version</i>
<i>validFrom</i>
<i>validTo</i>
<i>globalPurchaseItemID</i>
<i>binaryPurchaseItemID</i>
<i>weight</i>
<i>closed</i>
ServiceReference
<i>idRef</i>
ScheduleReference
<i>idRef</i>
PurchaseItemReference
<i>idRef</i>
Name
Description
StartTime
EndTime
ParentalRating
<i>ratingSystem</i>
<i>ratingValueName</i>
DependencyReference
<i>idRef</i>
ExclusionReference
<i>idRef</i>
Extension
<i>url</i>
Description
PrivateExt

#### 7.2.4.6.2 Purchase Data Fragment

Use of the Purchase Data fragment of the service guide shall conform to the specifications in Section 6.7 of A/153 Part 4 [8], with the following change:

- E1 element 'TermsOfUse' is added, exactly as it is specified in the OMA BCAST v1.0 Service Guide [56] Section 5.1.2.7.

To control the subscription/purchasing of certain NRT purchase items, it may be useful or even necessary from service provider policy and/or legal reasons to provide a "terms of use" advisory to the end user, as a precondition to fulfillment of the associated purchase transaction.

For those purchase items, the related E1 element ‘TermsOfUse’ in the PurchaseData fragment of the OMA BCAS T v1.0 Service Guide [56] should be included in the Purchase Data fragment. When ‘TermsofUse’ is present with its “type” attribute set to ‘0’, then it is recommended that the TermsOfUse/TermsOfUseText or TermOfUse/PreviewDataIDRef, as defined in the OMA BCAS T v1.0 Service Guide [56], be provided to the end-user, along with other descriptive information about the purchase items carried in other elements of the Service Guide.

The revised data structure of the Purchase Data fragment is shown in Table 7.11 (added parameter is highlighted).

**Table 7.11** PurchaseData Fragment

PurchaseData
<i>id</i>
<i>version</i>
<i>validFrom</i>
<i>validTo</i>
Description
PriceInfo
<i>subscriptionType</i>
MonetaryPrice
<i>currency</i>
SubscriptionPeriod
PurchaseItemReference
<i>idRef</i>
PurchaseChannelReference
<i>idRef</i>
PreviewDataReference
<i>idRef</i>
<i>usage</i>
TermsOfUse
<i>type</i>
<i>id</i>
<i>userConsentRequired</i>
Country
Language
PreviewDataIDRef
TermsOfUseText
PrivateExt

#### 7.2.4.6.3 Purchase Channel Fragment

Use of the Purchase Channel fragment of the service guide shall conform to the specifications in Section 6.8 of A/153 Part 4 [8].

#### 7.2.4.6.4 Preview Data Fragment

Use of the Preview Data fragment of the service guide shall conform to the specifications in Section 6.9 of A/153 Part 4 [8].

In particular, this fragment and the associated delivery machinery defined in the OMA BCAS T Service Guide specification [56] is used to provide icons for services and content items, via PreviewDataReference elements in the Service and Content fragments (with usage=“2”).

This means that the Icon Descriptor defined for the fixed SMT is not expected to be used for mobile NRT services.

## 8. BASIC DESCRIPTORS

This section provides definitions and other information about the descriptors which are referenced in this document, except for the Receiver Targeting Descriptor, which is defined in Section 9.2.

### 8.1 Protocol Version Descriptor (PVD)

The Protocol Version Descriptor is used to identify the major version numbers of associated data structures in the ATSC Standards. If the PVD indicates a major version number higher than that which a given receiver supports, that receiver is expected to disregard the associated service. If the PVD indicates a minor version number higher than that which a given receiver supports, that receiver is expected to attempt to present the service as usual. Certain bits in fields identified as containing “reserved” values in previous versions of the standard may be defined in later versions and associated with certain values of `minor_version_number`.<sup>10</sup>

The bit stream syntax of the Protocol Version Descriptor shall be as shown in Table 8.1.

**Table 8.1** Bit Stream Syntax for the Protocol Version Descriptor

Syntax	No. of Bits	Format
<code>protocol_version_descriptor() {</code>		
<b>descriptor_tag</b>	8	0xC3
<b>descriptor_length</b>	8	uimsbf
<b>protocol_identifier</b>	8	uimsbf
<b>major_protocol_version</b>	4	uimsbf
<b>minor_protocol_version</b>	4	uimsbf
for (i=0; i<N; i++) {		
<b>reserved</b>	8	bslbf
}		
}		

**descriptor\_tag** – This 8-bit unsigned integer shall have the value 0xC3, identifying this descriptor as a `protocol_version_descriptor()`.

**descriptor\_length** – This 8-bit unsigned integer shall specify the length (in bytes) immediately following this field up to the end of this descriptor.

**protocol\_identifier** – This 8-bit unsigned integer shall be used to indicate the protocol whose version is being identified in the major/minor protocol version fields to follow. The value of the `protocol_identifier` field shall be as defined in Table 8.2.

**Table 8.2** Protocol Identifier

protocol_identifier	Meaning
0x00	Forbidden
0x01	Legacy A/90 data services, conforming to ATSC A/90 [2]
0x02	IP Subnet defined in NRT standard
0x03	Non-Real-Time services
0x04 – 0x7F	Reserved for future use by ATSC
0x80 – 0xFF	Reserved for experimental use

**major\_protocol\_version** – This 4-bit unsigned integer shall specify the major portion of the protocol version. A change in the major\_protocol\_version shall indicate a non-backward compatible level of change.

**minor\_protocol\_version** – This 4-bit unsigned integer shall specify the minor portion of the protocol version. A change in the minor\_protocol\_version, provided the major\_protocol\_version remains the same, shall indicate a backward-compatible level of change.

When a Protocol Version Descriptor with protocol\_identifier value 0x01 is present in the program\_info descriptor loop of a PMT section, it shall indicate that the collection of all program elements of stream types 0x06, 0x0B, 0x0D, 0x14, 0x95 and 0xC2 in the associated MPEG-2 program constitute a data service that conforms to the ATSC A/90 Standard [2]. When a Protocol Version Descriptor with protocol\_identifier value 0x01 is present in the descriptor loop following ES\_info\_length of a subset of the program elements of a PMT section, it shall indicate that the program elements in that subset constitute a data service that conforms to the ATSC A/90 Standard [2]. In these situations the major\_protocol\_version value of 0x1 and minor\_protocol\_version value of 0x0 shall indicate that set of program elements conform to the July 2000 A/90 release with the April/May 2002 Amendment 1 and Corrigenda 1 and 2 [2].

When a Protocol Version Descriptor with protocol\_identifier value 0x02 is present in the program\_info descriptor loop of a PMT section, it shall indicate that the collection of all program elements of stream\_type 0x0D in the associated MPEG-2 program constitute an IP subnet that conforms to the specifications in this standard. When a Protocol Version Descriptor with protocol\_identifier value 0x02 is present in the descriptor loop following ES\_info\_length of a subset of the program elements of a PMT section, it shall indicate that the program elements in that subset constitute an IP subnet that conforms to the specifications in this standard. In these situations the values of major\_protocol\_version and minor\_protocol\_version shall be as defined in Table 8.3.

**Table 8.3** Protocol Version for protocol\_identifier = 0x02 (IP Subnet)

major_protocol_version	minor_protocol_version	Meaning
0x0	(don't care)	Forbidden
0x1	0x0	IP subnet and Service Signaling Channel (SSC as specified in the present standard, with the first byte of each table in the SSC giving the table_id of the table, and the fourth byte giving the protocol_version of the table.
0x1	0x1 – 0xF	Reserved for future use by ATSC
0x2 – 0xF	all	Reserved for future use by ATSC

When the protocol\_identifier field has value 0x03 (indicating NRT service) the values of major\_protocol\_version and minor\_protocol\_version shall be as defined in Table 8.4.

**Table 8.4** Protocol Version for protocol\_identifier = 0x03 (NRT)

major_protocol_version	minor_protocol_version	Meaning
0x0	(don't care)	Forbidden
0x1	0x0	NRT data structures and semantics as specified in the present NRT standard, not including those data structures and semantics for which version signaling is defined within the NRT standard.
0x1	0x1 – 0xF	Reserved for future use by ATSC
0x2 – 0xF	all	Reserved for future use by ATSC

If a protocol version is signaled by a Protocol Version Descriptor, and if different structures conforming to different versions of that protocol are present, then multiple instances of the Protocol Version Descriptor with the same protocol\_identifier value may appear.

## 8.2 NRT Service Descriptor

The NRT Service Descriptor indicates the presence of NRT components within a service, indicates the usage/consumption model for a non-real-time service, and gives other optional information about the service.

A variety of user experiences are possible for NRT services. An informative description of the usage/consumption models defined in this release of the standard may be found in Annex B.

Whenever a service contains NRT components, one instance of an NRT Service Descriptor shall be included in the SMT in the descriptor loop indicated by the term *service\_level\_descriptor()*.

The bit stream syntax for the NRT Service Descriptor shall be as shown in Table 8.5.

**Table 8.5** Bit Stream Syntax for the NRT Service Descriptor

Syntax	No. of Bits	Format
NRT_service_descriptor() {		
<b>descriptor_tag</b>	8	0xC4
<b>descriptor_length</b>	8	uimbsf
<b>reserved</b>	2	'11'
<b>consumption_model</b>	6	uimbsf
<b>auto-update</b>	1	bslbf
<b>storage_reservation_present</b>	1	bslbf
<b>default_content_size_present</b>	1	bslbf
<b>reserved</b>	5	'11111'
if (storage_reservation_present==1) {		
<b>storage_reservation</b>	24	uimbsf
if (default_content_size_present==1) {		
<b>default_content_size</b>	40	uimbsf
}		
for (j=0; j< N; j++) {		
<b>reserved</b>	8	bslbf
}		
}		

**descriptor\_tag** – This 8-bit unsigned integer shall have the value 0xC4, identifying this descriptor as an NRT\_service\_descriptor().

**descriptor\_length** – This 8-bit unsigned integer shall specify the length (in bytes) immediately following this field up to the end of this descriptor.

**consumption\_model** – This 6-bit unsigned integer shall signal the intended consumption model for the NRT service associated with the descriptor. NRT Service Categories shall be as defined in Table 8.6. Note: other categories of NRT services might be defined in future ATSC standards. Annex B of this Standard provides an informative description of the three NRT Service Categories defined here.

**Table 8.6** NRT Service Category

<b>consumption_model</b>	<b>Meaning</b>
0x00	Forbidden.
0x01	<b>Browse &amp; Download</b> – The NRT service describes content that can be selected for later download.
0x02	<b>Portal</b> – The NRT service provides an experience similar to a web browser access. Files needed to support text/graphics rendering are available in the associated FLUTE session.
0x03	<b>Push</b> – The NRT service offers request-based content. Receivers are expected to offer the user a choice whether or not to automatically update content associated with the service. For such services, if the user selects the auto-update option, the receiver caches and service-related content and automatically updates files as new versions are made available. When the user returns to a requested Push service, content that had been pre-loaded is displayed.
0x04 – 0x3F	Reserved for use by ATSC or other SDOs who register the use with ATSC.

**auto-update** – This Boolean flag shall specify, when set to ‘1’ that the option to auto-update the service should be offered to the user. When the flag is set to ‘0,’ no recommendation is expected to be given regarding the option to auto-update. The receiver is expected to pre-load content for those services for which the user has expressed an ongoing interest by agreeing to auto-update. Note: The auto-update option is analogous to the option offered by web browsers to “subscribe” to RSS feeds.

**storage\_reservation\_present** – This Boolean flag shall indicate, when set to ‘1’ that the `storage_reservation` field is present in the descriptor. When the flag is set to ‘0’ the `storage_reservation` field shall not be present.

**default\_content\_size\_present** – This Boolean flag shall indicate, when set to ‘1’ that the `default_content_size` field is present in the descriptor. When the flag is set to ‘0’ the `default_content_size` field shall not be present.

**storage\_reservation** – This 24-bit unsigned integer field shall indicate the recommended minimum number of kilobytes (one kilobyte equals 1024 bytes) of storage required in the receiver for successful handling of content delivered within this NRT service.

**default\_content\_size** – This 40-bit unsigned integer field shall indicate the default total size in bytes of any content Item in the NRT-IT for this service for which the `content_size` field in the NRT-IT is not present (i.e. for which the `content_size_included` field for the content item is set to ‘0’).

### 8.3 Capabilities Descriptor

The Capabilities Descriptor provides a list of “capabilities” (download protocols, FEC algorithms, wrapper/archive formats, compression algorithms, and media types) used for an NRT service or content item (depending on the level at which the descriptor appears), together with an indicator of which ones are deemed essential for meaningful presentation of the NRT service (either standalone or adjunct) or NRT content item. Receivers are expected to parse and process

the NRT Capabilities Descriptor and avoid offering a given service or content item to the user if the capabilities indicated as essential are not supported. A service or content item labeled with a set of capabilities shall be transmitted in a form that can be rendered by any receiver that satisfies the conditions indicated by each of the capabilities in the set.

All essential capabilities used for a service shall appear in a Capabilities Descriptor for the service. Capabilities needed to present non-essential parts of the service may appear as well.

All essential capabilities used for a content item beyond those already declared as essential in the service level Capabilities Descriptor shall appear in the Capabilities Descriptor for the content item. Capabilities needed to present non-essential parts of the content item (beyond those that appear in the service level Capabilities Descriptor) may appear as well.

There shall be no overlap between Capabilities listed in a Capabilities Descriptor for a service and the Capabilities listed in a Capabilities Descriptor for a content item of that service, except in the case when the Capability is listed as non-essential for the service but essential for the content item.

Note that in the case of an adjunct NRT service, even when the receiver cannot provide a meaningful presentation of the NRT service, it can often provide a meaningful presentation of the other content in the virtual channel.

The syntax for the Capabilities Descriptor shall conform to Table 8.7. The semantics of the fields in the Capabilities Descriptor are given immediately below the table.

**Table 8.7** Capabilities Descriptor Syntax

Syntax	No. of Bits	Format
<b>capabilities_descriptor() {</b>		
<b>descriptor_tag</b>	8	0xC5
<b>descriptor_length</b>	8	uimsbf
<b>Individual_capability_codes() {</b>		
<b>capability_code_count</b>	8	uimsbf
<b>for (i=0; i&lt;capability_code_count; i++) {</b>		
<b>essential_indicator</b>	1	bslbf
<b>capability_code</b>	7	uimsbf
<b>if (capability_code &gt; 0x6F) {</b>		
<b>format_identifier</b>	32	
<b>}</b>		
<b>}</b>		
<b>}</b>		
<b>Individual_capability_strings() {</b>		
<b>capability_string_count</b>	8	uimsbf
<b>for (i=0; i&lt;capability_string_count; i++) {</b>		
<b>essential_indicator</b>	1	
<b>capability_category_code</b>	7	
<b>capability_string_length</b>	8	uimsbf
<b>capability_string()</b>	var	uimsbf
<b>}</b>		
<b>}</b>		
<b>capability_or_sets() {</b>		

<b>capability_or_set_count</b>	<b>8</b>	<b>bslbf</b>
<b>for (k=0; k&lt; capability_or_set_count; k++) {</b>		
<b>essential_indicator</b>	<b>1</b>	<b>bslbf</b>
<b>capability_codes_in_set_count</b>	<b>7</b>	<b>uimsbf</b>
<b>for (i=0; i&lt;capability_codes_in_set_count; i++) {</b>		
<b>reserved</b>	<b>1</b>	
<b>capability_code</b>	<b>7</b>	<b>uimsbf</b>
<b>if (capability_code &gt; 0x6F) {</b>		
<b>format_identifier</b>	<b>32</b>	<b>uimsbf</b>
<b>}</b>		
<b>}</b>		
<b>capability_strings_in_set_count</b>	<b>8</b>	<b>uimsbf</b>
<b>for (i=0; i&lt;capability_strings_in_set_count; i++) {</b>		
<b>reserved</b>	<b>1</b>	
<b>capability_category_code</b>	<b>7</b>	
<b>capability_string_length</b>	<b>8</b>	<b>uimsbf</b>
<b>capability_string()</b>	<b>var</b>	<b>uimsbf</b>
<b>}</b>		
<b>}</b>		
<b>}</b>		
<b>for (j=0; j&lt; N; j++) {</b>		
<b>reserved</b>	<b>8</b>	<b>bslbf</b>
<b>}</b>		
<b>}</b>		

**descriptor\_tag** – This 8-bit unsigned integer shall have the value 0xC5, identifying this descriptor as a capabilities\_descriptor().

**descriptor\_length** – This 8-bit unsigned integer shall specify the length (in bytes) immediately following this field up to the end of this descriptor.

**capability\_code\_count** – This 8-bit unsigned integer field shall indicate the number of capability\_code values to follow.

**essential\_indicator** – This 1-bit field indicates whether support for the capability represented by the capability code following this field is essential for the meaningful presentation of the service or content item, or not. The value ‘1’ shall indicate that the capability is essential. The value ‘0’ shall indicate that it is not essential.

**capability\_code** – This 7-bit unsigned integer field shall represent a specific capability as defined in Table A.1.

**format\_identifier** – The format\_identifier is a 32-bit field as defined in ISO/IEC 13818-1 [53], Section 2.6.9 for the registration\_descriptor(). Only format\_identifier values registered and recognized by the SMPTE Registration Authority, LLC shall be used (see <http://www.smppte-ra.org/mpegreg.html>). Its use shall scope and identify only the capability\_code immediately preceding it.

**capability\_string\_count** – This 8-bit unsigned integer field shall indicate the number of capability\_string values to follow.

**essential\_indicator** – This 1-bit field indicates whether support for the capability represented by the capability string following this field is essential for the meaningful presentation of the service

or content item, or not. The value ‘1’ shall indicate that the capability is essential. The value ‘0’ shall indicate that it is not essential.

**capability\_category\_code** – This 7-bit unsigned integer field shall indicate the capability category for the string value following it, using the appropriate code from Table 8.8.

**capability\_string\_length** – This 8-bit unsigned integer field shall specify the length (in bytes) of the capability\_string() following it.

**capability\_string()** – This shall be a string containing the representation of a capability. The value of this string shall be as specified in Table 8.8 and the specifications following it.

**capability\_or\_set\_count** – This 8-bit unsigned integer field shall indicate the number of capability “OR sets” to follow. The capability codes and capability strings in each capability “OR set” shall be combined with “OR” logic to represent a combined capability. I.e., a receiver satisfies a capability “OR set” if and only if it satisfies at least one of the capability codes or capability strings in the set.

**essential\_indicator** – This 1-bit field indicates whether support for the capability represented by the capability “OR set” following this field is essential for the meaningful presentation of the service or content item, or not. The value ‘1’ shall indicate that the capability is essential. The value ‘0’ shall indicate that it is not essential.

**capability\_codes\_in\_set\_count** – This 7-bit unsigned integer field shall represent the number of capability codes in the set of capabilities.

**capability\_code** – This 7-bit unsigned integer field shall represent a specific capability as defined in Table A.1.

**format\_identifier** – The format\_identifier is a 32-bit field as defined in ISO/IEC 13818-1 [53], Section 2.6.9 for the registration\_descriptor(). Only format\_identifier values registered and recognized by the SMPTE Registration Authority, LLC shall be used (see <http://www.smp-te-ra.org/mpegreg.html>). Its use here shall scope and identify only the capability code immediately preceding it.

**capability\_strings\_in\_set\_count** – This 8-bit unsigned integer field shall represent the number of capability strings in the set of capabilities.

**capability\_category\_code** – This 7-bit unsigned integer field shall indicate the capability category for the string value following it, using the appropriate code from Table 8.8.

**capability\_string\_length** – This 8-bit unsigned integer field shall specify the length (in bytes) of the capability\_string() following it.

**capability\_string()** – This shall be a string containing the representation of a capability. The value of this string shall be as specified in the paragraphs following Table 8.8 for the corresponding value in the **capability\_category\_code**.

**Table 8.8** Capability Categories and Registries

capability_category_code	Capability Category	Registry
0x00	reserved	
0x01	Download Protocol	No registry – use widely used industry name
0x02	FEC Algorithm	IANA registry of FEC encoding IDs and instance IDs [65]
0x03	Wrapper/Archive Format	IANA registry of media types and subtypes [64]
0x04	Compression Algorithm	IANA registry of HTTP Content-Coding values [63]
0x05	Media Type	IANA registry of media types and subtypes [64]
0x06-0x7F	reserved	

A string representation of a capability shall only be used for capabilities that do not have a **capability\_code** listed in Table A1. When a string is used, the following paragraphs define the contents of the string.

The string representation of a capability category code value of 0x01 (Download Protocol) shall be the commonly used industry name for the protocol.

The string representation of a Fully-Specified FEC algorithm shall consist of the decimal integer representation of the FEC encoding ID as it appears in the IANA registry. The string representation of an Under-Specified FEC algorithm shall consist of the decimal representation of the FEC encoding ID as it appears in the IANA registry, followed by a slash (/) delimiter, followed by the decimal representation of the FEC instance as it appears in the IANA registry.

For the purposes of this Standard, a wrapper/archive format is defined as a format that can aggregate multiple other media elements into a single file. String representations of wrapper/archive formats shall be the IANA media type/subtype designations formed according to RFC 2045 [29] that represent formats fitting this definition (e.g., video/mp4 or application/zip). Unregistered media types shall be permitted, specifically including experimental types (i.e., “x-“) and those in widespread commercial use.

The string representation of a compression algorithm shall be the Name of the Content-Coding value as it appears in the IANA registry.

The string representation of a media type shall be the IANA media type/subtype designations formed according to RFC 2045 [29] that represent formats not fitting the definition of a wrapper/archive, possibly augmented by parameter values as specified by the standards defining specific media types. Unregistered media types shall be permitted, specifically including experimental types (i.e., “x-“) and those in widespread commercial use (e.g., “audio/wav”).

#### 8.4 Icon Descriptor

The Icon Descriptor provides a reference to an image file in a FLUTE session of the service that can be used as a service or content icon.

Minimum resolutions for icon graphics are not specified. Implementers should be aware that low-resolution graphics can create a poor viewer impression when rendered on large-screen displays.

The bit stream syntax of the Icon Descriptor shall be as shown in Table 8.9.

**Table 8.9** Bit Stream Syntax for the Icon Descriptor

Syntax	No. of Bits	Format
icon_descriptor() {		
<b>descriptor_tag</b>	8	0xC6
<b>descriptor_length</b>	8	uimsbf
<b>icon_content_linkage</b>	32	uimsbf
for (i=0; i<N; i++) {		
<b>reserved</b>	8	bslbf
}		
}		

**descriptor\_tag** – This 8-bit unsigned integer shall have the value 0xC6, identifying this descriptor as an icon\_descriptor().

**descriptor\_length** – This 8-bit unsigned integer shall specify the length (in bytes) immediately following this field up to the end of this descriptor.

**icon\_content\_linkage** – The value of this 32-bit unsigned integer field shall correspond to a FLUTE FDT content linkage tag of the file containing the icon image. Icons shall be PNG or JPEG graphics. For a particular NRT service, the value of icon\_content\_linkage shall be unique over the set of linkage values for all content items and icons in the service from the time when the content item or Icon Descriptor first appears in the NRT-IT or any of its files appear in FLUTE FDT instances to the time when the content item or Icon Descriptor no longer appears in the NRT-IT and none of its files appear in FLUTE FDT instances (taking into account the “Expires” attribute of the FLUTE FDT instances).

## 8.5 ISO-639 Language Descriptor

The ISO-639 Language Descriptor defined in ISO/IEC 13818-1 [53] Section 2.6.18, if present at the service level in the SMT or the content item level in the NRT-IT, shall indicate the language(s) of audio and/or textual components associated with the given service or content item. The presence of Visually Impaired and/or Hearing Impaired audio tracks in the given content item may also be signaled. Within the context of its use in the NRT-IT, the following constraints shall apply to the use of the ISO-639 Language Descriptor:

- For the audio\_type codes described below, the first indicated language with a given code shall indicate the primary (or “main”) language associated with the service or content item. Additional languages, if present, shall indicate other languages available in some or all content within the service or content item.
- A value of 0x00 in the audio\_type byte in the descriptor shall indicate audio in the specified language is present in the service or content item.
- A value of 0x02 in the audio\_type byte in the descriptor shall indicate Hearing Impaired audio in the specified language is present in the service or content item.
- A value of 0x03 in the audio\_type byte in the descriptor shall indicate Visual Impaired audio in the specified language is present in the service or content item.
- A value of 0x10 in the audio\_type byte in the descriptor shall indicate text in the specified language is present in the service or content item.
- A value of 0x11 in the audio\_type byte in the descriptor shall indicate captions in the specified language are present in the service or content item.

## 8.6 FLUTE Component Descriptor Extension

If the transmission has employed the update channel usage described in Section 5.7, the FLUTE (type 38) descriptor is used to signal that the update convention is in use, as other usages for multiple FLUTE channels might be possible. To do so, a revised syntax of the A/153 FLUTE descriptor with a formerly reserved bit defined shall be used. The syntactical placement shall be as shown in Table 8.10, with semantics below the table. All other syntax and semantics in the descriptor shall retain the syntax and semantics specified in A/153 Part 3 [7] Table 7.14 and supporting text.

**Table 8.10** Bit Stream Syntax for Component Data for FLUTE File Delivery (Type 38) as Modified For NRT

Syntax	No. of Bits	Format
component_data() {		
<b>TSI</b>	16	uimbsf
<b>session_start_time</b>	32	uimbsf
<b>session_end_time</b>	32	uimbsf
<b>reserved</b>	4	'1111'
<b>update_channel_flag</b>	1	bslbf
<b>tias_bandwidth_indicator</b>	1	bslbf
<b>as_bandwidth_indicator</b>	1	bslbf
<b>FEC_OTI_indicator</b>	1	bslbf
if (tias_bandwidth_indicator == '1') {		
<b>tias_bandwidth</b>	16	uimbsf
}		
if (as_bandwidth_indicator == '1') {		
<b>as_bandwidth</b>	16	uimbsf
}		
if (FEC_OTI_indicator == '1') {		
<b>FEC_encoding_id</b>	8	uimbsf
<b>FEC_instance_id</b>	16	uimbsf
}		
}		

**update\_channel\_flag** – A 1-bit field that signals the usage of an update notification channel. This bit shall be set to '1' to indicate that the first channel in the set of channels defined for the component can be employed as an update notification channel (in which case the port\_num\_count field of the component loop in the SMT must specify a value greater than 1, as required below), and it shall be set to '0' to indicate that the first channel cannot be so interpreted, even if there is more than one channel.

A FLUTE session that employs the update channel usage shall signal the number of channels in use (including the update channel) by indicating a value greater than 1 for the port\_num\_count field of the appropriate component entry within the service.

Note that there is no way to signal explicitly the bitrate split between the channels, as this is specified only as a maximum total bitrate at the component level.

### 8.7 Time Slot Descriptor

The Time Slot Descriptor encodes a time interval or set of repeating time intervals. The semantics of the time interval(s) depend on the type of time slot, as encoded in the time\_slot\_type field in the descriptor. The bit stream syntax of the Time Slot Descriptor shall be as shown in Table 8.11, with semantics as defined immediately after Table 8.11.

One or more instances of a time\_slot\_descriptor() of time slot type "Acquisition Slot" shall be present in each content-level descriptor loop in each NRT\_information\_table\_section().

**Table 8.11** Bit Stream Syntax for the Time Slot Descriptor

Syntax	No. of Bits	Format
time_slot_descriptor() {		
<b>descriptor_tag</b>	8	0xC8
<b>descriptor_length</b>	8	uimsbf
<b>time_slot_start</b>	32	uimsbf
<b>time_slot_length</b>	16	uimsbf
<b>time_slot_type</b>	3	uimsbf
<b>time_slot_params_length</b>	3	uimsbf
<b>repeating</b>	1	bslbf
<b>reserved</b>	1	'111'
<b>time_slot_params</b>	var	
if (repeating=='1') {		
<b>repeat_period</b>	16	uimsbf
<b>slot_count</b>	8	uimsbf
}		
for (i=0; i<N; i++) {		
<b>reserved</b>	8	bslbf
}		
}		

**descriptor\_tag** – This 8-bit unsigned integer shall have the value 0xC8, identifying this descriptor as a time\_slot\_descriptor().

**descriptor\_length** – This 8-bit unsigned integer shall specify the length (in bytes) immediately following this field up to the end of this descriptor.

**time\_slot\_start** – This 32-bit unsigned integer shall represent the start time of the time slot(s) as the number of GPS seconds since 00:00:00 UTC, 6 January 1980. A value of zero for time\_slot\_start shall indicate the time slot began in the indefinite past.

**time\_slot\_length** – This 16-bit unsigned integer shall represent the length of the time slot in minutes.

**time\_slot\_type** – This 3-bit unsigned integer shall represent the time slot type, encoded as specified in Table 8.12 below.

**time\_slot\_params\_length** – This 3-bit unsigned integer shall represent the length of the time\_slot\_params field, in bytes. The value of the time\_slot\_params\_length field shall be set as specified in Table 8.12 below, depending on the value of the time\_slot\_type field.

**repeating** – A 1-bit Boolean flag that shall indicate, when set, that the repeat\_period and slot\_count fields are present in the descriptor; i.e. a repeating time slot is specified. A value of '0' shall indicate the repeat\_period and slot\_count fields are not present. If the value of time\_slot\_start is zero, the repeating flag shall be set to '0.'

**time\_slot\_params** – This variable length field shall contain sub-fields to further describe properties of the time slot. The sub-fields of the time\_slot\_params field shall have syntax as specified in Table 8.12 below, depending on the value of the time\_slot\_type field, with semantics as defined below Table 8.12.

**Table 8.12** Time Slot Types and Parameters

Time Slot Type	time_slot_type value	time_slot_params_length value	time_slot_params		
			Syntax	No. of Bits	Format
Acquisition Slot	0	2	reserved	4	'1111'
			acquisition_time	12	uimsbf
ATSC Reserved	1-7				

Each time interval encoded by a Time Slot Descriptor of type Acquisition Slot shall indicate a period when the associated content item is available, in the sense that a complete transmission of the content item, including any FEC sent with the content item, occurs after any point during the interval. A receiver can acquire the content item by starting acquisition at any time during the time interval, including right at the end of the interval, barring unrecoverable errors in receiving the transmission. The semantics of the time slot parameters for an Acquisition Slot are:

**acquisition\_time** – This 12-bit unsigned integer shall represent the minimum time interval length, in minutes, which is needed to guarantee that at least one complete instance of the content item will be transmitted during the time interval, assuming that the time interval starts at any arbitrary time during the time slot, including right at the end of the time slot. (If a single large content item is being transmitted repeatedly during the time slot, this will be the time it takes to transmit a single instance of the content item. If a number of small content items are being transmitted in a carousel, this will be the carousel cycle time.)

**repeat\_period** – This 16-bit unsigned integer shall represent the period of repetition of the time slot in minutes.

The relationships between `time_slot_start`, `time_slot_length`, and `repeat_period` are diagrammed in Figure 8.1. In the example, the time slot appears three times.

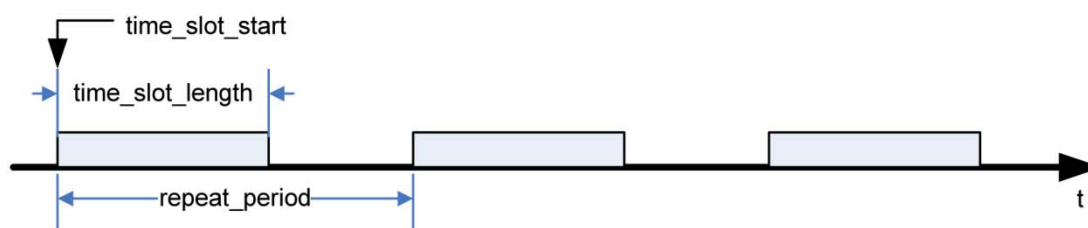
**Figure 8.1** Parameters in Time Slot Descriptor – Example.

**slot\_count** – This 8-bit unsigned integer in the range 0 to 255 shall indicate the number of times the time slot will occur, starting at the time slot beginning at `time_slot_start`. A value of zero for `slot_count` shall indicate the repetition shall be assumed to continue indefinitely.

## 8.8 Internet Location Descriptor

The Internet Location Descriptor provides one or more Uniform Reference Locators (URLs) referencing content items that may be retrieved via the Internet.

The bit stream syntax for the Internet Location Descriptor shall be as shown in Table 8.13.

**Table 8.13** Bit Stream Syntax for the Internet Location Descriptor

Syntax	No. of Bits	Format
internet_location_descriptor() {		
<b>descriptor_tag</b>	8	0xC9
<b>descriptor_length</b>	8	uimsbf
<b>reserved</b>	3	'111'
<b>URL_count</b>	5	uimsbf
for (i=0; i<URL_count; i++) {		
<b>URL_length</b>	8	uimsbf
<b>URL()</b>	var	
}		
for (j=0; j< N; j++) {		
<b>reserved</b>	8	bslbf
}		
}		

**descriptor\_tag** – This 8-bit unsigned integer shall have the value 0xC9, identifying this descriptor as an internet\_location\_descriptor().

**descriptor\_length** – This 8-bit unsigned integer shall specify the length (in bytes) immediately following this field up to the end of this descriptor.

**URL\_count** – This 5-bit unsigned integer field shall indicate the number of URL references (URL\_length/URL() pairs) in this instance of the descriptor.

**URL\_length** – This 8-bit unsigned integer shall specify the length in bytes of the URL to follow.

**URL()** – This field is a character string which represents the Uniform Reference Locator per RFC 3986 [39], of a piece of referenced content. The URI scheme shall be either http: or https:.

## 8.9 Associated Service Descriptor

An Associated Service Descriptor is intended for the service level descriptor loop of an M/H service, to indicate that it has one or more adjunct NRT services.

The syntax of the Associated Service Descriptor is given in Table 8.14. The semantic definitions of the fields in the descriptor follow the table.

**Table 8.14** Bit Stream Syntax for the Associated Service Descriptor

Syntax	No. of Bits	Format
associated_service_descriptor() {		
<b>descriptor_tag</b>	8	0xCA
<b>descriptor_length</b>	8	uimsbf
<b>num_associated_services</b>	8	uimsbf
for (j=0; j<num_associated_services; j++) {		
<b>associated_service</b>	16	uimsbf
}		
}		

**descriptor\_tag** – This 8-bit unsigned integer shall have the value 0xCA, identifying this descriptor as an associated\_service\_descriptor().

**descriptor\_length** – This 8-bit unsigned integer shall specify the length (in bytes) immediately following this field up to the end of this descriptor.

**num\_associated\_services** – This 8-bit unsigned integer shall specify the number of associated NRT services listed in this descriptor.

**associated\_service** – This 16-bit unsigned integer shall match the *service\_id* of an NRT service (*service\_category* value 0x0E), indicating that the NRT service is an adjunct NRT service for the service in which this descriptor appears.

## 9. RECEIVER TARGETING

### 9.1 Introduction

The receiver targeting mechanism specified here is based on the optional association of targeting criteria with services or individual content items. In the case of fixed broadcasts, the targeting criteria are contained in a Receiver Targeting Descriptor that can go in the descriptor loop of a service in the SMT or in the descriptor loop of a content item in the NRT-IT. In the case of mobile broadcasts, the targeting criteria are contained in a Receiver Targeting XML element that can go in the *PrivateExt* element of a Service fragment or Content fragment of the Service Guide.

The initial specifications of the Receiver Targeting Descriptor and the *TargetUserProfile* and *TargetArea* elements support optional targeting on the basis of certain demographic categories and/or geographic location (indicated by FIPS codes or alphanumeric postal codes or, for mobile broadcasts, circular areas identified by the radius and latitude/longitude coordinates of the center of the circle). These can be supplemented by the Genre and Content Advisory descriptors (or *Genre* and *ParentalRating* elements). A mechanism is also specified for future extension of the targeting criteria.

The basic concept behind receiver targeting is that certain values for certain targeting criteria are associated with content items or services. A receiver that supports receiver targeting will provide a mechanism for setting values of receiver/viewer properties corresponding to the targeting criteria. If a particular targeting value for a particular criterion matches a receiver/viewer value for the corresponding property, then the value is said to be “true”; otherwise it is “false”.

The Receiver Targeting Descriptor and element each allow multiple values to be provided for some of the targeting criteria. The intended targeting logic is “OR” logic among multiple values for the same targeting criterion, and “AND” logic among different targeting criteria.

A Targeting Criterion Table is also specified, which can be used to extend the set of targeting criteria in the future. The table allows the specification of (1) a criterion type code to identify a new targeting criterion and (2) a collection of values for the new criterion. The table includes text descriptions of the new criterion and each of the values for it, which can be used by the receiver when letting a viewer select the values that apply to the receiver/viewer. The criterion type code forms part of the *table\_id\_extension* of the table, so multiple instances of the table can be defined for multiple new criteria.

### 9.2 Receiver Targeting Descriptor

In an ATSC fixed-broadcast emission, one or more instances of the *receiver\_targeting\_descriptor()* defined below may go in the descriptor loop of an NRT service in the SMT or in the descriptor

loop of a content item in the NRT-IT. In the former case they shall apply to all content items of the service. In the latter case they shall apply to the individual content item.

The `receiver_targeting_descriptor()` shall have the syntax specified in Table 9.1, and the semantics defined immediately following the table.

**Table 9.1** Bit Stream Syntax for the Receiver Targeting Descriptor

Syntax	No. of Bits	Format
<code>receiver_targeting_descriptor() {</code>		
<b>descriptor_tag</b>	8	0xC7
<b>descriptor_length</b>	8	uimbsf
<b>num_targeting_entries</b>	8	uimbsf
for (i=0; i<num_targeting_entries; i++) {		
<b>targeting_criterion_type_code</b>	5	uimbsf
<b>targeting_value_length_minus_1</b>	3	uimbsf
<b>targeting_value</b>	var	
}		
for (j=0; j< N; j++) {		
<b>reserved</b>	8	bslbf
}		
}		

**num\_targeting\_entries** – This 8-bit unsigned integer shall give the number of targeting entries in the loop following this field (where each entry has a `targeting_criterion_type_code`, `targeting_value_length`, and `targeting_value`).

**targeting\_criterion\_type\_code** – This 5-bit unsigned integer shall specify the type of value contained in the `targeting_value` field. The values for `targeting_criterion_type_code` shall be defined as shown in Table 9.2.

**Table 9.2** Targeting Criterion Type Codes

targeting_criterion_type_code	targeting_value_length	targeting_value
0x00	N/A	Reserved
0x01	3 bytes	Geographical location as defined in Table 6.21 of A/65 [13], using only the low order 3 bytes.
0x02	var	Alphanumeric postal code as defined in section 6.7.2 of A/65 [13], using the number of bytes appropriate to the region (up to 8).
0x03	2 bytes	Demographic category as defined in Table 6.18 of A/65 [13], using only the low order 2 bytes.
0x04 – 0x0F	N/A	Reserved for future ATSC use
0x10 – 0x1F	N/A	Available for private use

**targeting\_value\_length\_minus\_1** – This 3-bit unsigned integer field shall specify the number of bytes used for the `targeting_value` of this entry. The actual number of bytes for the `targeting_value` is obtained by adding one to the value of `targeting_value_length_minus_1`.

Note: This field is included to allow extensibility of the set of targeting criteria in a backward compatible fashion.

**targeting\_value** – This variable-length unsigned integer field shall contain the targeting value, with semantics as specified in Table 9.2.

If num\_targeting\_entries is greater than one, the result of each entry in the “for” loop shall be evaluated as an intermediate term, returning “true” if the targeting\_value matches a value for the receiver/viewer property corresponding to the targeting\_criterion\_type\_code, and returning “false” otherwise. Among these intermediate terms, those with the same value of target\_criterion\_type\_code shall be logically ORed to obtain the interim result for each targeting criterion, and these interim results shall be logically ANDed together to determine the final result. If the final result evaluates to True for a receiver, it shall imply that the associated NRT service or content item is targeted at that receiver.

### 9.3 Receiver Targeting XML Element

The OMA BCASST SG TargetUserProfile element (which appears in both the Service and Content fragments) has the following XML schema definition.

---

```
<xs:element name="TargetUserProfile" type="TargetUserProfileType"
  minOccurs="0" maxOccurs="unbounded"/>

<xs:complexType name="TargetUserProfileType">
  <xs:attribute name="attributeName" type="xs:string"
use="required"/>
  <xs:attribute name="attributeValue" type="xs:string"
use="required"/>
</xs:complexType>
```

---

When used in Mobile DTV NRT broadcasts, this element shall conform to the specifications of the OMA BCASST SG standard, with the following additional constraints:

- 1) The value of the “attributeName” attribute shall be the XML hexBinary representation of one of the targeting\_criterion\_type\_code values given in Table 9.2 of Section 9.2, excluding values 0x01 and 0x02, with semantics as defined in Section 9.2 for that value.
- 2) The value of the “attributeValue” attribute shall be the XML hex Binary representation of an allowable targeting\_value as specified in Table 9.2 of Section 9.2, with semantics as defined in Section 9.2 for that value.

Note: Table 9.2 may be extended in future versions of this Standard, and the Targeting Criterion Table defined in Section 9.4 may be used to download extensions to Table 9.2 for deployed receivers.

The OMA BCASST SG BroadcastArea element (which appears in both the Service and Content fragments) has the following XML schema definition:

---

```
<xs:complexType name="BroadcastAreaType">
  <xs:sequence>
    <xs:element name="TargetArea" minOccurs="0" maxOccurs="unbounded">
      <xs:complexType>
        <xs:choice>
          <xs:element name="shape">
            <xs:annotation>
```

---

---

```

        <xs:documentation> See [55]</xs:documentation>
    </xs:annotation>
    <xs:complexType>
        <xs:sequence>
            <xs:any minOccurs="0" maxOccurs="unbounded"
                namespace="##other" processContents="skip"/>
        </xs:sequence>
    </xs:complexType>
</xs:element>
<xs:element name="cc" type="xs:unsignedShort">
    <xs:annotation>
        <xs:documentation> See [55] </xs:documentation>
    </xs:annotation>
</xs:element>
<xs:element name="mcc" type="MCCType"/>
<xs:element name="name_area" type="LanguageString"
    maxOccurs="unbounded">
    <xs:annotation>
        <xs:documentation> See [55]. The instances of this element
only differ in language.
        </xs:documentation>
    </xs:annotation>
</xs:element>
<xs:element name="ZipCode" type="xs:string"/>
<xs:element name="CellTargetArea" type="CellTargetAreaType" />
</xs:choice>
</xs:complexType>
</xs:element>
<xs:element name="lev_conf" type="LevConfType" minOccurs="0">
    <xs:annotation>
        <xs:documentation> See [55] </xs:documentation>
    </xs:annotation>
</xs:element>
</xs:sequence>
<xs:attribute name="polarity" type="xs:boolean" use="optional"
default="true"/>
</xs:complexType>

```

---

When used in Mobile DTV NRT broadcasts, this element shall conform to the OMA BCASST SG specifications, with the following additional constraints:

- 1) The string value of the name\_area element shall have the format SS[,CCC[,S]], where the square brackets [ ] indicate optional substrings, and where “SS” is a decimal representation of state\_code as defined in Table 6.21 of A/65 [13], “CCC” is the decimal representation of the county\_code as defined in Table 6.21 of A/65, and “S” is the decimal

representation of the county\_subdivision as defined in Table 6.21 of A/65 [13]. The optional xml:lang attribute of the name\_area element shall not appear.

- 2) The value of the ZipCode element shall be an alphanumeric postal code as defined in Section 6.7.2 of A/65 [13], using the number of bytes appropriate to the region (up to 8).
- 3) The following element may be used as an instantiation of the “xs:any” sub-element of the “shape” element:

```
<element name="CircularArea">
  <complexType>
    <sequence>
      <element name="coord">
        <complexType>
          <sequence>
            <element name="X">
              <simpleType>
                <restriction base="float">
                  <minInclusive value="-180"/>
                  <maxInclusive value="180"/>
                </restriction>
              </simpleType>
            </element>
            <element name="Y">
              <simpleType>
                <restriction base="float">
                  <minInclusive value="-90"/>
                  <maxInclusive value="90"/>
                </restriction>
              </simpleType>
            </element>
            <element name="scr" type="integer"/>
          </sequence>
        </complexType>
      </element>
      <element name="radius" type="unsignedInt"/>
      <element name="distanceUnit" type="string" minOccurs="0"/>
    </sequence>
    <attribute name="gid" type="string" use="optional"/>
    <attribute name="srsName" type="string" use="optional"/>
  </complexType>
</element>
```

This element represents a circular area, with center given by the “coord” element and radius given by the “radius” element.

The “gid” element, which represents an identifier for the CircularArea element instance, has no defined semantics within this Standard.

The Coordinate Reference System (CRS) for the CircularArea element is WGS84 [70]. The “srsName” attribute, which represents an identifier of the CRS for the element, shall not appear.

The “radius” element shall give the radius of the circular area in meters. The “distanceUnit” element shall not appear.

The element X shall give the longitude of the center of the circular area, in degrees, with 0 representing points on the prime meridian, negative values representing points west of the prime meridian, and positive values representing points east of the prime meridian. The element Y shall give the latitude of the center of the circular area, in degrees, with 0 representing points on the equator, negative values representing points south of the equator, and positive values representing points north of the equator.

All instances of the TargetUserProfile element, if any, shall be evaluated as an individual term, returning “true” if the targeting values in the sub-element matches a value for the receiver/viewer property corresponding to that sub-element, and returning “false” otherwise. Among these intermediate terms, all instances that have the same value for the “attributeName” attribute shall be logically ORed to obtain the interim result for that targeting criterion, and these interim results shall be logically ANDed together to determine an overall TargetUserProfile result. Similarly, the BroadcastArea element shall be evaluated as specified in the OMA BCAST SG to determine whether the receiver lies within the target area or not, and this result shall be ANDed with the TargetUserProfile result to determine whether the service or content item is targeted to the receiver or not.

#### **9.4 Targeting Criterion Table**

The downloadable Targeting Criterion Table defined below can be used to define a new targeting criterion, giving its type code, a text label for the criterion, the length of its value field, the set of its allowable values, and a text label for each value, thus providing a backwards compatible way to extend the initial set of targeting criteria. An NRT receiver can use such a table to provide a user interface that allows a user to indicate which value or values of the criterion best represent that user.

Since the `targeting_criterion_type_code` appears as a subfield of the `table_id_extension` field, there may be multiple instances of this table for multiple new targeting criteria.

The Targeting Criterion Table shall have the syntax specified in Table 9.3, with the semantics as specified immediately after the table.

**Table 9.3** Bit Stream Syntax for the Targeting Criterion Table

Syntax	No. of Bits	Format
targeting_criterion_table_section() {		
<b>table_id</b>	8	0xE7
<b>section_syntax_indicator</b>	1	'0'
<b>private_indicator</b>	1	'1'
<b>reserved</b>	2	'11'
<b>section_length</b>	12	uimsbf
table_id_extension {		
<b>TCT_protocol_version</b>	8	uimsbf
<b>targeting_criterion_type_code</b>	5	uimsbf
<b>targeting_value_length_minus_1</b>	3	uimsbf
}		
<b>reserved</b>	2	'11'
<b>version_number</b>	5	uimsbf
<b>current_next_indicator</b>	1	'1'
<b>section_number</b>	8	uimsbf
<b>last_section_number</b>	8	uimsbf
<b>criterion_type_text_length</b>	8	uimsbf
<b>criterion_type_text()</b>	var	
<b>num_values</b>	8	
for (i=0; i<num_values; i++) {		
<b>targeting_value</b>	8*(targeting_value_length_minus_1 +1)	uimsbf
<b>value_text_length</b>	8	uimsbf
<b>value_text()</b>	var	
}		
}		

Semantic definitions are provided here only for those fields that are not part of the standard “long-form” MPEG-2 private section syntax.

**table\_id** – This 8-bit field shall be set to 0xE7 to identify this table section as belonging to the Targeting Criterion Table.

**TCT\_protocol\_version** – This 8-bit field indicates the version of the syntax and semantics of this table instance. The value for the TCT\_protocol\_version field shall be 0x10 for the initial version of this standard, where the high order 4 bits indicate the major version number and the low order 4 bits indicate the minor version number. New values of TCT\_protocol\_version may be used in future versions of this standard to indicate structurally different tables.

**targeting\_criterion\_type\_code** – This 5-bit field shall contain the code value for the targeting criterion represented by this table instance, to be used in the targeting\_criterion\_type\_code field of Receiver Targeting Descriptors for fixed NRT broadcasts, and in the attributeName attribute of TargetUserProfile elements for mobile NRT broadcasts.

**targeting\_value\_length\_minus\_1** – This 3-bit field shall indicate the length of the targeting\_value field in Receiver Targeting Descriptor entries for the targeting criterion represented by this table

instance. The length of that field in bytes shall be one greater than the value of the `targeting_value_length_minus_1` field.

**version\_number** – This 5-bit field is the version number of the entire Targeting Criterion Table (TCT). A TCT shall be identified by the combination of `table_id` and `table_id_extension`. The `version_number` shall be incremented by 1 modulo 32 when a change in the information carried within the TCT occurs.

**current\_next\_indicator** – This 1-bit indicator shall always be set to ‘1’ for TCT sections; the TCT sent is always currently applicable.

**section\_number** – This 8-bit field shall give the section number of this TCT section, where the TCT is identified by the combination of `table_id` and `table_id_extension`. The `section_number` of the first section in a TCT shall be 0x00. The `section_number` shall be incremented by 1 with each additional section in the TCT.

**last\_section\_number** – This 8-bit field shall give the number of the last section (i.e., the section with the highest `section_number`) of the TCT of which this section is a part.

**criterion\_type\_text\_length** – This 8-bit field shall give the number of bytes in the `criterion_type_text()` field immediately following it.

**criterion\_type\_text()** – This field shall contain a description of the targeting criterion represented by this table instance, possibly in multiple languages, in the format of an ATSC multiple string structure (see A/65 [13] Section 6.10).

**num\_values** – This 8-bit field shall give the number of iterations of the loop immediately following it.

**targeting\_value**– This field shall give the code of a targeting value for the targeting criterion represented by this table instance, to be used in the `targeting_value` field of a Receiver Targeting Descriptor for fixed NRT broadcasts, and the `attributeValue` attribute of `TargetUserProfile` elements for mobile NRT broadcasts.

**value\_text\_length** – This 8-bit field shall give the number of bytes in the `value_text()` field immediately following it.

**value\_text()** – This field shall contain a description of the targeting value represented by the `targeting_value` in this iteration of the loop, possibly in multiple languages, in the format of an ATSC multiple string structure (see A/65 [13] Section 6.10).

When an instance of this table is delivered to support an NRT Virtual Channel in an ATSC fixed-broadcast emission, each section shall be delivered as the payload of a UDP datagram in the Service Signaling Channel of the NRT Virtual Channel. When an instance is delivered to support an NRT service in an ATSC Mobile DTV Broadcast, each section shall be delivered as the payload of a UDP datagram in the Service Signaling Channel of each ensemble in that M/H Broadcast which is marked in the FIC-Chunk as containing the Guide Access Table.

The Directed Channel Change Selection Code Table (DCCSCT), defined in ATSC A/65 [13], may be used to update the sets of State FIPS code values and County FIPS code values used for the geographical location criterion in the Receiver Targeting Descriptor for fixed NRT broadcasts and for the `name_area` sub-element of the `TargetArea` element for mobile NRT broadcasts. It may also be used to extend the set of genre values for the Genre Descriptor in fixed

NRT broadcasts and the genre element in mobile NRT broadcasts. When so used in fixed NRT broadcasts, it shall be delivered as specified in Section 6.8 of ATSC A/65 [13]. When so used in mobile NRT broadcasts, each section of it shall be delivered in a UDP datagram in the same Service Signaling Channel(s) as specified above for the Targeting Criterion Table.

## **10. INTERACTION CHANNEL**

The presence of an interaction channel is optional. When an interaction channel is present, it shall conform to ATSC A/96 [6] Sections 6 and 7. Other protocols may be supported, including those defined in Sections 8 and 9.

IPv4 and IPv6 addressing shall both be supported.

Device provisioning is not defined here, but shall meet the requirements of A/96 [6] Section 7.3.

---

# *Annex A*

## Capability Code Details

### A.1 OVERVIEW OF CAPABILITY SIGNALING

Signaling and announcement data for NRT services and content items include enough information such that any given NRT receiver can determine:

- Whether or not it has sufficient resources (codecs, support for certain media types and distribution formats) for it to be able to offer a meaningful presentation of that service (if not, the service can be skipped over);
- Whether or not it has sufficient resources to be able to decode and present any particular item of NRT content that may be associated with a service that passes the first test (if not, that content can be skipped over).

The concept of “capability codes” is used to signal receiver capability requirements at both the service level and the content item level, supplemented by strings if necessary to represent protocols, formats or algorithms that do not appear in the table of capability codes. Different capability code values represent different media types, wrapper formats, FEC algorithms, compression algorithms and download protocols. A given audio or video codec may have more than one defined capability code, reflecting different capability profiles in the receiver. For example, AVC video at up to level 4.0 is assigned one capability code, while AVC video at levels up to 4.2 is assigned a different capability code.

A Capabilities Descriptor appears in the Service Map Table as part of the description of each NRT service. It can list one or more essential capabilities needed for a meaningful presentation of the service, using "capability code" values to represent certain specific capabilities defined in Annex A, and also string values to represent other capabilities. A receiver may choose not to make available to the user a certain NRT service if it determines it cannot offer a meaningful presentation.

A Capabilities Descriptor can also appear in the NRT-IT at the content item level to list one or more essential capabilities for a meaningful presentation of specific content items, above and beyond the essential capabilities listed as essential at the service level for a meaningful presentation of the service. For example, a particular content item may be desirable, but not essential to the overall service, and it may require capabilities above and beyond those needed for the other essential items in the service. A receiver may choose not to make available to the user a certain content item if it determines it cannot offer a meaningful presentation of it.

The Capabilities Descriptor can also include capabilities that are needed to present non-essential parts of a service or content item.

The capability codes are listed in Table A.1.

As an example, consider that in the future a new video codec is developed called “Flowmagic.” A Media Type string value of “video/x-flowmagic” is used to identify Flowmagic content. If a service requires the receiver to support the Flowmagic codec, it would include a Media Type string `video/x-flowmagic` in the Capabilities Descriptor at the service level. Receivers

not recognizing the video/x-flowmagic Media Type would understand that they do not have the necessary decoding resources, and may choose not to offer that service.

Note that in some instances, decoding capability may be present in a different device in the network. A receiver may be able to determine that some external device could handle this content, and choose to offer it for download on that basis.

Annex C further illustrates these concepts.

## A.2 LIST OF CAPABILITY CODES WITH SEMANTICS

The following is the table of capability codes for the Capabilities Descriptor defined in Section 8.3. The referenced sections in the table describe normative requirements in detail for the given capability code. For codecs, the wrapper formats that must be supported are listed. For Browser Profiles, the compression formats that must be supported are listed.

**Table A.1** Capability Codes

capability_code	Meaning	Reference
0x00	Forbidden	
Download Protocols		
0x01	FLUTE protocol, as specified in this Standard.	
0x02-0x0F	Reserved for future ATSC use.	
FEC Algorithms		
0x10	Compact No-Code FEC scheme.	Section A.2.1
0x11	Raptor algorithm, as specified in this Standard.	Section A.2.2
0x12-0x1F	Reserved for future ATSC use.	
Wrapper/Archive Formats		
0x20	DECE CFF container general format	Section A.2.3.1
0x21	ZIP format, as specified in this Standard.	Section 5.7
0x22	DECE CFF container format, Profile PD.	Section A.2.3.2
0x23	DECE CFF container format, Profile SD.	Section A.2.3.3
0x24	DECE CFF container format, Profile HD.	Section A.2.3.4
0x25	ISO Base Media File Format for AAC audio	Section A.2.4
0x26	ATSC compliant MPEG-2 transport stream	Section A.2.5
0x27-0x2F	Reserved for future ATSC use.	
Compression Algorithms		
0x30	DEFLATE algorithm, as specified in this Standard.	
0x31-0x3F	Reserved for future ATSC use.	
Media Types		
0x41	AVC standard definition video	Section A.2.6
0x42	AVC high definition video	Section A.2.7
0x43	AC-3 audio	Section A.2.8
0x44	E-AC-3 audio	Section A.2.9
0x45	MP3 audio	Section A.2.10
0x46	Browser Profile A	Section A.2.11
0x47	Reserved	
0x48	Atom per RFC 4287 [36].	Section A.2.12
0x49	AVC mobile video	Section A.2.13
0x4A	HE AAC v2 mobile audio	Section A.2.14
0x4B	HE AAC v2 level 4 audio	Section A.2.15

capability_code	Meaning	Reference
0x4C	DTS-HD audio	Section A.2.16
0x4D	CFF-TT	Section A.2.17
0x4E	CEA-708 captions	Section A.2.18
0x4F	HE AAC v2 with MPEG Surround	Section A.2.19
0x50-0x6F	Reserved for future ATSC use.	
0x70-0x7F	Available for private use.	

### A.2.1 Capability Code 0x10: Compact No-Code FEC Scheme

The capability\_code value 0x10 shall represent the receiver ability to support the “Compact No-Code FEC scheme” [42] (FEC Encoding ID 0), which shall include:

- A receiver for the Compact No-Code FEC scheme such that if a receiver receives all the source symbols generated according to the FEC code specification in [42] for reconstruction of a source block then the receiver shall recover the entire source block. Note that the Example Receivers described in [42] Clause 3.4.2 fulfills this requirement.
- Recovery of a source block with a maximum size 262,144 bytes.
- The FEC Payload ID format as defined in [42] Clause 3.2.1, and
- The FEC Object Transmission Information format as defined in [42] Clause 3.2.2.

### A.2.2 Capability Code 0x11: Raptor Algorithm

The capability\_code value 0x11 shall represent the receiver ability to support the “Raptor FEC scheme” [43] (FEC Encoding ID 1), which shall include:

- A decoder for the Raptor FEC scheme such that if a receiver receives a mathematically sufficient set of encoding symbols generated according to the Encoder Specification in [43] for reconstruction of a source block then the decoder shall recover the entire source block. Note that the Example Decoder described in [43] Clause 5.5 fulfills this requirement.
- Decoding of a sub-block with maximum size 262,144 bytes.
- The FEC Payload ID format as defined in [43] Clause 3.1, and
- The FEC Object Transmission Information format as defined in [43] Clause 3.2.

### A.2.3 DECE CFF Multimedia Container Format

The DECE Common File Format Specification (CFF) [17] is built on a framework established in the Protected Interoperable File Format (PIFF) [69]. The CFF specification defines a general format and three specific Media Profiles – PD for portable devices, SD for standard definition devices and HD for high definition devices.

#### A.2.3.1 Capability Code 0x20: DECE CFF general format

The capability\_code value 0x20 shall represent the receiver ability to support the DECE multimedia container format defined in DECE “Common File Format & Media Formats Specification” [17] (excluding the Annexes). This does not imply the ability to support any of the specific content types that can be carried in a file with this format.

This code value shall not be used to describe files conforming to the DECE profiles that are defined in Annexes A-C of the DECE CFF specification [17]. (The three currently defined profiles each have been assigned their own capability code in the sections below.) Use of this code value requires a media type capability code in order to completely describe a file’s content.

When the capability code 0x20 is used, at least one media type capability code shall be associated with this code value.

#### A.2.3.2. Capability Code 0x22: PD Media Profile

The `capability_code` value 0x22 shall represent the receiver ability to support the PD Media Profile of the CFF multimedia container format, defined in DECE “Common File Format & Media Formats Specification,” Annex A [17]. This implies the ability to support the DECE CFF general format, the ability to support AVC video with the constraints specified in section A.4 of Annex A, and the ability to support MPEG-4 AAC (2 channel) audio with the constraints specified in section A.5 of Annex A. When this capability code appears along with certain other capability codes, it modifies the specifications defined by those codes, as indicated in the specifications of those capability codes.

#### A.2.3.3. Capability Code 0x23: SD Media Profile

The `capability_code` value 0x23 shall represent the receiver ability to support the SD Media Profile of the CFF multimedia container format defined in DECE “Common File Format & Media Formats Specification,” Annex B [17]. This implies the ability to support the DECE CFF general format, the ability to support AVC video with the constraints specified in section B.4 of Annex B, and the ability to support MPEG-4 AAC (2 channel) audio with the constraints specified in section B.5 of Annex B. When this capability code appears along with certain other capability codes, it modifies the specifications defined by those codes, as indicated in the specifications of those capability codes.

#### A.2.3.4. Capability Code 0x24: HD Media Profile

The `capability_code` value 0x24 shall represent the receiver ability to support the HD Media Profile of the CFF multimedia container format defined in DECE “Common File Format & Media Formats Specification,” Annex C [17]. This implies the ability to support the DECE CFF general format, the ability to support AVC video with the constraints specified in section C.4 of Annex C, and the ability to support MPEG-4 AAC [2 channel] audio with the constraints specified in section C.5 of Annex C. When this capability code appears along with certain other capability codes, it modifies the specifications defined by those codes, as indicated in the specifications of those capability codes.

### A.2.4 Capability Code 0x25: ISO Base Media File Format for AAC Audio

The `capability_code` value 0x25 shall represent the receiver ability to support ISO Base Media Files according to [51] and MP4 File Format according to [52] when carrying AAC<sup>10</sup> audio [46], constrained as follows:

- The 'moov' box shall be positioned after the 'ftyp' box before the first 'mdat'. If a 'moof' box is present, it shall be positioned before the corresponding 'mdat' box.
- Within a track, chunks shall be in decoding time order within the media-data box 'mdat'. The duration of samples stored in a chunk should not exceed 1 second.

---

<sup>10</sup> The AAC family of codecs includes HE AAC v2 Profile, Level 2 (used for Mobile DTV) and HE AAC v2 Profile, Level 4 (supporting discrete multichannel), which are identified separately with capability codes 0x4A and 0x4B.

- If the size of 'moov' box becomes bigger than 2.5 Mbytes, the file shall be fragmented by using 'moof' box. The size of 'moov' boxes shall be equal to or less than 2.5 Mbytes. The size of 'moof' boxes shall be equal to or less than 300 Kbytes.
- The sample size box ('stsz') shall be used. The compact sample size box ('stsz2') shall not be used.
- The largesize defined in 4.2 of [51] shall not be used. Note that larger MP4 files are still able to be generated and used by means of 'fragments.'
- The stco box defined in 8.19 of [51] shall be used. i.e., the co64 box defined in Clause 8.19 of [51] shall not be used.

#### **A.2.5 Capability Code 0x26: ATSC Compliant MPEG-2 Transport Stream**

The `capability_code` value 0x26 shall represent the receiver ability to support a file that has the format of a sequence of MPEG-2 transport stream packets consisting of all the audio and video packets of one virtual channel (MPEG-2 program) conforming to ATSC A/53 Part 3 [3], Part 4 [4] and Part 5 [5], plus PSI tables (PAT and PMT) describing that program. This capability code implies the ability to parse the MPEG-2 transport stream structure specified in the MPEG-2 systems standard [53] and the ability to decode audio, video and closed captions as specified in A/53.

#### **A.2.6 Capability Code 0x41: AVC Standard Definition Video**

The `capability_code` value 0x41 shall represent the receiver ability to support AVC video encoded in conformance with the specifications in A/72 Part 1 [14] for SD resolutions. The `capability_code` value 0x41 shall not appear along with `capability_code` values 0x22, 0x23, or 0x24, since each of these code values implies support for AVC with certain specified constraints.

#### **A.2.7 Capability Code 0x42: AVC High Definition Video**

The `capability_code` value 0x42 shall represent the receiver ability to support AVC video encoded in conformance with the specifications in A/72 Part 1 [14] for HD resolutions. The `capability_code` value 0x42 shall not appear along with `capability_code` values 0x22, 0x23, or 0x24, since each of these code values implies support for AVC with certain specified constraints.

#### **A.2.8 Capability Code 0x43: AC-3 Audio**

When `capability_code` value 0x43 appears along with `capability_code` value 0x23, it shall represent receiver support for AC-3 audio as constrained in section B.5 of Annex B of the DECE CFF specification [17]. When `capability_code` value 0x43 appears along with `capability_code` value 0x24, it shall represent receiver support for AC-3 audio as constrained in section C.5 of Annex C of the DECE CFF specification [17]. When `capability_code` value 0x43 appears without `capability_code` values 0x23 or 0x24, it shall represent the receiver ability to support AC-3 audio encoded in conformance with A/53 Part 5 [5].

#### **A.2.9 Capability Code 0x44: Enhanced AC-3 Audio**

When `capability_code` value 0x44 appears along with `capability_code` value 0x23, it shall represent receiver support for Enhanced AC-3 audio as constrained in section B.5 of Annex B of the DECE CFF specification [17]. When `capability_code` value 0x44 appears along with `capability_code` value 0x24, it shall represent receiver support for Enhanced AC-3 audio as constrained in section C.5 of Annex C of the DECE CFF specification [17]. When `capability_code` value 0x44 appears

without `capability_code` values 0x23 or 0x24, it shall represent the receiver ability to support Enhanced AC-3 audio encoded in conformance with A/52 [1], and constrained as specified below. Receivers supporting `capability_code` value 0x44 also support `capability_code` 0x43 (AC-3 Audio).

#### A.2.9.1. Enhanced AC-3 Elementary Stream Constraints

Enhanced AC-3 elementary streams shall be constrained as follows:

- data rate** – The data rate of an Enhanced AC-3 elementary stream shall be less than or equal to  $3024 \times 10^3$  bits/second.
- fskod** – An Enhanced AC-3 elementary stream shall be encoded at a sample rate of 48 kHz, hence the value of the `fskod` parameter in all frames of an Enhanced AC-3 elementary stream shall be set to 0x0.
- bsid** – The value of the `bsid` parameter in all frames of an Enhanced AC-3 elementary stream shall be set to 0x10.
- substreams** – An Enhanced AC-3 elementary stream shall always contain at least one independent substream (stream type ‘0’) with a substream ID of ‘0’. An Enhanced AC-3 elementary stream may also additionally contain one dependent substream (stream type ‘1’). The number of substreams shall remain constant for the duration of an Enhanced AC-3 elementary stream.
- strmtyp** – The value of the `strmtyp` parameter in all frames of independent substream 0 shall be set to 0x0. The value of the `strmtyp` parameter in all frames of dependent substream 0, if present, shall be set to 0x1.
- substreamid** – The value of the `substreamid` parameter in all frames of an Enhanced AC-3 elementary stream shall be set to 0x0.
- acmod** – All audio coding modes except dual mono (`acmod`=‘000’) defined in Table 4.3 of ATSC A/52 [1] are permitted. The value of `acmod` shall remain constant for the duration of an Enhanced AC-3 elementary stream.
- lfeon** – The value of the `lfeon` parameter shall remain constant for the duration of an Enhanced AC-3 elementary stream.
- chanmap** – The value of the `chanmap` parameter shall remain constant for the duration of an Enhanced AC-3 elementary stream
- bsmod** - The value of the `bsmod` parameter shall remain constant for the duration of an Enhanced AC-3 elementary stream.

#### A.2.9.2. Substream Configuration for Delivery of More than 5.1 Channels of Audio

To deliver more than 5.1 channels of audio, both independent (Stream Type 0) and dependent (Stream Type 1) substreams are included in the Enhanced AC-3 elementary stream. The channel configuration of the complete elementary stream is defined by the “`acmod`” parameter carried in the independent substream, and the “`acmod`” and “`chanmap`” parameters carried in the dependent substream. The loudspeaker locations supported by Enhanced AC-3 are defined in SMPTE 428-3 [71]. The following rules apply to channel numbers and substream use:

- When more than 5.1 channels of audio are to be delivered, independent substream 0 of an Enhanced AC-3 elementary stream shall be configured as a downmix of the complete program.
- Additional channels necessary to deliver up to 7.1 channels of audio shall be carried in dependent substream 0.

### **A.2.10 Capability Code 0x45: MP3 Audio**

The `capability_code` value 0x45 shall represent the receiver ability to support MP3 audio encoded in conformance with ISO/IEC 13818-3 [50].

### **A.2.11 Capability Code 0x46: Browser Profile A**

The `capability_code` value 0x46 shall represent the receiver ability to support all normative requirements of the Browser Profile A-capable Receiver (BPACR) specified in Annex D (page 122).

### **A.2.12 Capability Code 0x48: Atom**

The `capability_code` value 0x48 shall represent the receiver ability to support the Atom syndication format specification RFC 4287 [36].

### **A.2.13 Capability Code 0x49: AVC Mobile Video**

The `capability_code` value 0x49 shall represent the receiver ability to support AVC video encoded in conformance with Section 7 of A/153 Part 7 [9]. The `capability_code` value 0x49 shall not appear along with `capability_code` values 0x22, 0x23, or 0x24, since each of these code values implies support for AVC with certain specified constraints.

### **A.2.14 Capability Code 0x4A: HE AAC v2 Mobile Audio**

When `capability_code` value 0x4A appears along with `capability_code` value 0x22, it shall represent receiver support for HE AAC v2 audio as constrained in section A.5 of Annex A of the DECE CFF specification [17]. When `capability_code` value 0x4A appears without `capability_code` value 0x22, it shall represent the receiver ability to support HE AAC v2 audio encoded in conformance with Section 5 of A/153 Part 8 [10].

### **A.2.15 Capability Code 0x4B: HE AAC v2 Profile, Level 4 Audio**

The `capability_code` value 0x4B shall represent the receiver ability to support HE AAC v2 audio encoded in conformance with HE AAC v2 Profile, Level 4 [46].

### **A.2.16 Capability Code 0x4C: DTS-HD Audio**

When `capability_code` value 0x4C appears along with `capability_code` value 0x23, it shall represent receiver support for DTS-HD audio as constrained in section B.5 of Annex B of the DECE CFF specification [17]. When `capability_code` value 0x4C appears along with `capability_code` value 0x24, it shall represent receiver support for DTS-HD audio as constrained in section C.5 of Annex C of the DECE CFF specification [17]. When `capability_code` value 0x4C appears without `capability_code` value 0x23 or 0x24, it shall represent the receiver ability to support DTS-HD audio encoded in conformance with Reference [19], subject to the constraints given below. DTS-HD has a unique data structure so that the bitstream whether it is stereo, 5.1, 7.1 or lossless is fully backwards compatible to the DTS core decoder. The functionality of decoding capability such as 5.1, 7.1 or lossless can be implemented individually.

The following constraints apply in addition to those described in Reference [19]:

- Bit rate range:
  - Stereo: 48 – 1524 kbps
  - 5.1: 128 – 4224 kbps
  - 7.1: 447 – 6075 kbps

- Lossless: VBR up to 24,576 kbps
- Sampling frequency: 44.1, 48, 96 and 192 KHz
- Duration of Synchronized Frame: 512, 1024, 2048, or 4096 samples per channel.

#### **A.2.17 Capability Code 0x4D: CFF-TT**

When the `capability_code` value 0x4D appears along with `capability_code` 0x20, it shall represent the receiver ability to support SMPTE Timed Text as constrained in section 6 of the DECE Common File Format and Media Formats Specification [17]. When `capability_code` value 0x4D appears along with `capability_code` values 0x22, 0x23 or 0x24, it shall represent the receiver ability to support SMPTE Timed Text as constrained in Annexes A, B and C respectively of the DECE CFF specification [17].

#### **A.2.18 Capability Code 0x4E: CEA 708 Captions**

The `capability_code` value 0x4E shall represent the receiver ability to support CEA-708 captions as specified in CEA-708 [15].

#### **A.2.19 Capability Code 0x4F: HE AAC v2 Audio with MPEG Surround**

The `capability_code` value 0x4F shall represent the receiver ability to support HE AAC v2 audio with MPEG Surround, as constrained in section A.5 of the DECE CFF specification [17].

---

# *Annex B*

## NRT Service Categories

### B.1 INTRODUCTION

A non-real-time service makes available to a receiver one or more media files. In some cases, files can be retrieved from the broadcast multiplex while the user waits (low latency), while in other cases, the files will be included in the broadcast at a later time. It may be that the receiver can start to retrieve the files immediately but their size and rate of delivery is such that the user will need to return later to view the content after the download completes.

Three distinct “consumption models” are described in the ATSC NRT standard, each corresponding with a different user experience as the receiver manages the presentation of the files associated with the NRT service. This Annex describes in further detail the three defined models, which are “Browse and Download,” “Push,” and “Portal.” Briefly:

- **Browse and Download** – This type of NRT service describes content that can be selected for later download. One aspect of the user interface involves describing to the user the available content; another involves allowing the user to navigate among previously downloaded content items to make selections for viewing.
- **Push** – The Push NRT service offers request-based content. Receivers are expected to offer the user a choice whether or not to automatically update content associated with the service. For such services, if the user selects the auto-update option, the receiver caches and service-related content and automatically updates files as new versions are made available. When the user returns to a requested Push service, content that had been pre-loaded is displayed.
- **Portal** – A Portal NRT service provides an experience similar to a web browser access. Files comprising the textual and graphical elements constituting a web page are made available in the associated FLUTE sessions. The service provider is expected to distribute files associated with Portal services in near-real-time, so that the receiver can build the display while the viewer waits.

Table B.1 describes some of the characteristics of these three models, and lists some typical content types and applications.

### B.2 BROWSE AND DOWNLOAD

The “look and feel” of the Browse and Download NRT service is completely determined by the receiver manufacturer. A wide variety of implementations are possible, ranging from the very simple to the elegantly sophisticated. There are two basic operations expected to be supported by the receiver’s user interface to the Browse and Download service: the function whereby the user browses for content to be retrieved from the digital broadcast, and the function wherein he or she chooses to view previously downloaded content.

In the Browse and Download NRT service, content is typically delivered slower than real-time. Content formats typically are audio/video, but can also be audio-only or websites, which are declarative content such as would be displayed by a web browser, possibly with embedded audio/video elements in addition to text and graphics.

The Browse and Download NRT service is best for offerings of long-form entertainment programming such as past episodes of an episodic series, although shorter-form content may be offered as well.

**Table B.1** Typical Expected Content Types and Characteristics of NRT Usage Models

	Typical Expected Content Types and Applications	Updates to Certain Content Items May be Offered	Content Provided in Near-Real-Time	Receiver Implementation Defines “Look and Feel” of UI	User Given Choice to “Subscribe” to Service
Browse & Download	A/V—Long-form entertainment programming. A/V—Short-form entertainment programming. A/V—music videos.	No (typically)	No	Yes	No
Push	Text/graphics—news, sports scores, weather, traffic, travel advisories, stock quotes. A/V—short clips (same subjects).	Yes	Yes or No	Yes	Yes
Portal	Text/graphics—broadcaster’s “home” page. Text/graphics—local sports team’s “home” page. Text/graphics—Content provider’s “home” page (for episode or series, for example).	Yes	Yes	No	No

### B.2.1 Browsing For Content

A receiver is expected to present a Browse and Download type of NRT service by first offering to the user a list of the available content titles associated with the service. The user interface is expected to involve the display of descriptive information about each content item, such as title and description, parental rating (if available), language, captioning information (when available), playback time, and genre (when provided). The user may interact with the receiver to browse amongst available titles, and (if the receiver supports it), perform search and/or filter operations on the metadata.

The user may select one or more available content items for download and later viewing. Items so selected may be labeled graphically with a symbol indicating “selected for download,” or may be deleted from the selection list once chosen.

Figure B.1 shows an example user interface to illustrate the concept. The graphic at the upper left was provided as a service icon. At the left is a list of content titles available for selection. When the user highlights a title, in this case “Wild Stickleberries,” details about the program or

episode are shown at the right. The user can highlight the “SELECT” button and, if activated, cause this episode to be scheduled for download. In this example, additional episodes of the same program may be browsed by using the right arrow on the remote.

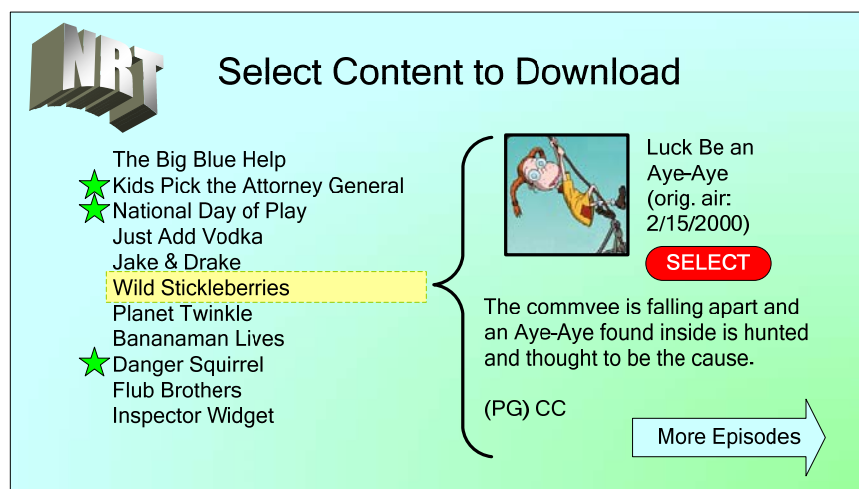

**Figure B.1** Example content selection UI.

Many other types and formats of user interface are possible when implementing the content selection function. NRT content can be integrated with other program guide data, for example, so that a search can yield both linear as well as NRT programming.

### B.2.2 Selecting Content for Viewing

A second user interface aspect of the Browse and Download NRT service is the function which allows selection of previously-downloaded content for playback. This function is analogous to the TiVo™ “Now Playing” screen. The user is given the opportunity to select an item for playback, scrolling through a number of pages as necessary. Typically, through a secondary screen or pop-up window, detailed information about a given item may be viewed. Such information could include (in addition to title and description):

- An icon descriptive of the content (such as a thumbnail JPEG or PNG graphic)
- Other selection-related metadata (genre, content advisory, captioning info, language, etc.)
- Playback time
- Date originally downloaded (or age in days)
- Storage requirements (or percentage of available disk space the content occupies)

Note that in some instances, playback may start before the whole file is retrieved. Metadata available to the receiver includes a parameter letting the receiver know how much time to wait following retrieval of the first byte of the file before playback may begin. Starting earlier than the recommended time would likely cause buffer underflow, and a pause in playback. Note that while playback controls are expected to support trick play modes (pause, fast-forward and rewind at different speeds, slow speed, etc.), fast-forwarding when the complete file is not yet recovered can lead to interruption in playback as the needed portion of the file is retrieved.

### B.3 PUSH

Similar in function to an RSS news feed on the Internet, an NRT “Push” service offers continuously-updated content pertaining to topics of interest to the user. Initially, when interacting with a Push NRT service, the user is given one or more topic areas and asked whether or not he or she is interested in receiving continuous updates when new information pertaining to that topic area is available. Returning to the RSS analogy, registering such interest is analogous to “subscribing” to a particular RSS feed. As the term “subscription” may be confused with for-pay services (such as when one “subscribes” to basic cable), the term “auto-update” may be used instead for the Push NRT service.

Figure B.2 illustrates an example of a Push service called “Sports News Feed Service,” which offers the viewer the option to choose from among six local sports teams of interest. If the “subscribe” option is taken, the receiver identifies that particular content item as something that should be downloaded right away and then continuously monitored for updates. This way, the content associated with that item will be fresh the next time the user visits the service.

Note that one “choice” (one “content item”) may actually represent one or more files. In the example of Figure B.2, each item corresponds to a mini website, comprised of declarative content (HTML, scripts, and graphics).

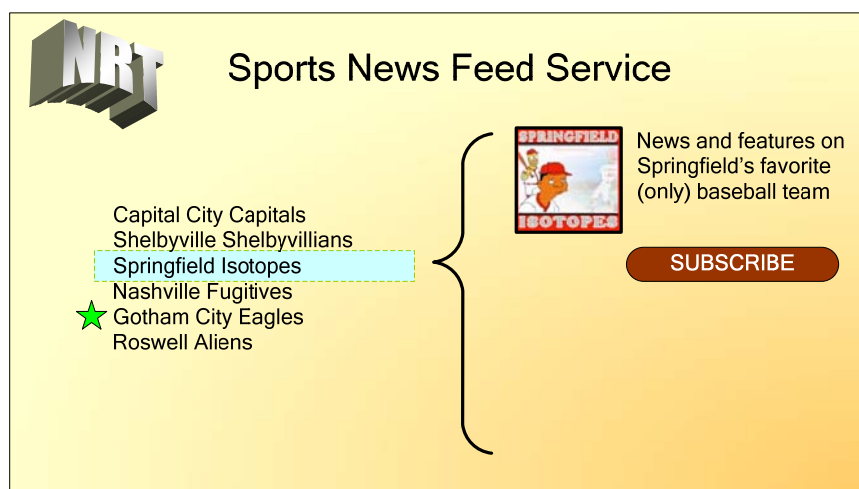

**Figure B.2** Example Push service subscription screen.

A Push NRT service is suitable for content such as sports scores, news, weather, stock market conditions, or anything of a time-sensitive nature where that latest information on the topic will be of value.

As with the Browse and Download NRT service, the look and feel of the Push service is totally at the discretion of the receiver manufacturer. The use of graphics, remote control keys, color schemes, and fonts can be chosen to match the receiver’s standard user interface format and style.

### B.4 PORTAL

A Portal NRT service is intended to offer an experience similar to browsing the Internet using a web browser. Unlike the Browse & Download and Push NRT services, content offered via a

Portal service is made available with low latency: once selected, the user need not wait very long before content is retrieved from the broadcast multiplex and rendered onscreen.

Also unlike the other two categories, the on-screen appearance of the content provided in a Push service is defined by the declarative content itself. As with a typical web browser, the receiver may offer the user options such as font size and zoom controls, but the layout of text and graphics is defined by the content creator.

The ATSC NRT standard defines a “browser profile” that NRT-capable receivers are expected to implement. This profile establishes specific capabilities for support of media formats including specific features of HTML, EcmaScript, cascading style sheets, document object models, graphics objects, and many other factors.

The Portal service can be equated to a mini-website. As mentioned, an item of content within an NRT service corresponds to one or more files. Whenever an item of content includes more than one file, one will be labeled as the “entry” point. Declarative content consisting of HTML, scripts, and graphics would likely label one of the HTML files as the entry point (like an “index.html” file). As the receiver processes the entry point file, references to other files (such as graphics objects, or to other HTML pages via hyperlinks) may be encountered.

Figure B.3 depicts an example NRT Portal service that is the home page of a hypothetical broadcaster called WMM as it might be rendered on a widescreen DTV display.



Figure B.3 Portal page example.

---

# *Annex C*

## Capability Code Signaling Example

### C.1 SCOPE

The signaling mechanisms defined in this Standard are designed to allow delivery of a wide variety of media formats, including formats not listed or anticipated at the time of publication of the Standard. This Annex provides an illustrative example of an NRT service that includes such components, and shows how the content provider can control whether or not certain content items described as part of a service are offered to the user. The example also illustrates the principle that the metadata describing content and services must be sufficient to prevent a situation where the user is offered the opportunity to download a content item that cannot be rendered, or that (if rendered) produces an unacceptable user experience.

### C.2 EUROPEAN TRAVEL DESTINATION NRT SERVICE EXAMPLE

In this example, an NRT “browse and download” service is offered. The details are as follows:

**Table C.1** Example Service Description

<b>Service Name:</b>	“European Travel Destinations”
<b>NRT Service Category:</b>	Browse & Download
<b>Capability Codes:</b>	“Browser Profile A”
<b>Content:</b>	A “mini website” for each of three different destinations, Greece, France, and Turkey.

The content items offered with this service consist of the following. Note: the example refers to a fictitious codec called “MagicFlow”:

**Table C.2** Example Content Description

<p><b>Content Item Name: “Greece”</b></p> <ul style="list-style-type: none"> <li>• ZIP file containing several HTML pages, many JPEG images</li> <li>• Consists of text and graphics with travel information for Greece, a page on rail transportation, a page on food, a page on lodging, etc.</li> <li>• NRT-IT Capabilities Descriptors: none</li> </ul>
<p><b>Content Item Name: “France”</b></p> <ul style="list-style-type: none"> <li>• ZIP file containing several HTML pages, many JPEG images, and ES (ECMAScript) files</li> <li>• Consists of text and graphics with travel information for France, a page on rail transportation, a page on food, a page on lodging, etc.</li> <li>• Includes an animated flag on the masthead of the home page, using a Magicflow plug-in (Content-Type=application/x-magicflow)</li> <li>• NRT-IT Capabilities Descriptors: none</li> </ul>
<p><b>Content Item Name: “Turkey”</b></p> <ul style="list-style-type: none"> <li>• ZIP file containing several HTML, JPEG images, and ES (ECMAScript) files</li> <li>• Consists primarily of a Magicflow slide show of travel destinations in Turkey, with accompanying text and fixed graphics</li> <li>• NRT-IT Capabilities Descriptor: video/x-magicflow</li> </ul>

Any receiver that can handle Browser Profile A is expected to offer the “European Travel Destinations” service to the user (all receivers are expected to support Browser Profile A). A receiver that does not recognize Media Type “video/x-magicflow” is expected to NOT offer “Turkey” as an available content item. Such a receiver, when rendering “France” is expected to process the script associated with the Magicflow plug-in, and act accordingly, meaning that it will gracefully discard aspects of the content it does not recognize or support. In this example, depending upon how the script is authored, the site may cause a fixed graphic to be rendered in the area that the waving flag would have occupied.

Table C.3 illustrates the behavior of these two receivers.

**Table C.3** Receiver Behavior

	Receiver #1	Receiver #2
Supports Browser Profile A	Yes	Yes
Supports Media Type video/x-magicflow	Yes	No
Offers “Greece”	Yes	Yes
Offers “France”	Yes	Yes
Displays animated waving flag:	Yes	No
Offers “Turkey”	Yes	No

---

# *Annex D*

## **“Browser Profile A” Specification**

### **D.1 SCOPE**

This establishes the normative definition of “Browser Profile A,” corresponding to capability\_code value 0x46.

### **D.2 BROWSER PROFILE A**

Browser Profile A is defined as a list of required capabilities that, when implemented in an NRT receiver, allow it to properly render declarative content created for such receivers. The protocols specified here are derived from or normative references to CEA-2014 [16], a standard for a suite of client/server protocols for Remote User Interface (RUI). CEA-2014 specifies requirements for an RUI client in which client/server interactions are specified. In the NRT application, the client is only responsible for rendering the content provided in one or more files. Therefore, only the portions of CEA-2014 pertaining to declarative content formats and features are cited here.

A receiver capable of supporting Browser Profile A shall be considered a BPACR (Browser Profile A-capable receiver). The following sections specify mandatory requirements for the BPACR.

#### **D.2.1 CE-HTML**

The BPACR shall support the subset of the “CE-HTML-1.0” protocol specified in CEA-2014 Sections 5.4 through 5.10 specified in the following sections.

##### **D.2.1.1. XHTML**

The BPACR shall support XHTML 1.0 Strict or Transitional as specified in CEA-2014 Section 5.4 item 1). Content authored in accordance with Browser Profile A shall conform with XHTML authoring guidelines C.8 of [58].

##### **D.2.1.2. ECMA-262**

The BPACR shall support ECMA-262 scripting language as specified in CEA-2014 Section 5.4 item 2).

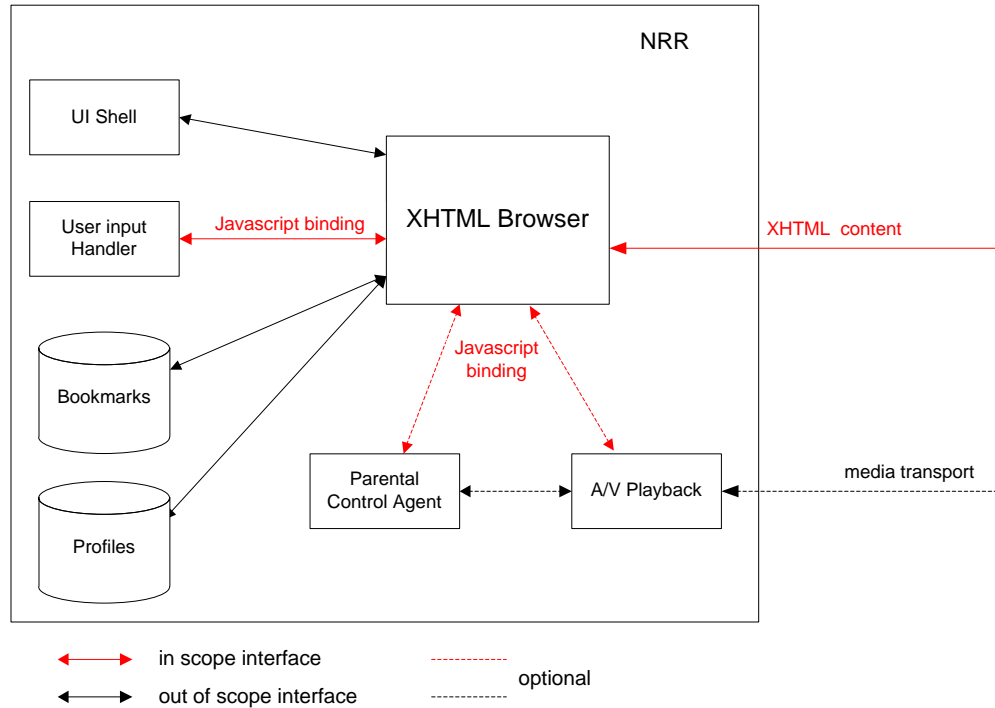

**Figure D.1** XHTML browser block diagram.

#### D.2.1.3. DOM 2

The BPACR shall support Document Object Model Level 2 Specification, including mandatory support for the ECMAScript language bindings specified in CEA-2014 Section 5.4 item 3).

#### D.2.1.4. ECMAScript Direct Access

The BPACR shall support ECMAScript direct access as specified in CEA-2014 Section 5.4 item 5).

#### D.2.1.5. CSS

The BPACR shall support Cascading Style Sheets 2.1 as specified in CEA-2014 Section 5.4 item 7).

#### D.2.1.6. Graphics

The BPACR shall support graphics objects in GIF, PNG, and JPG formats as specified in CEA-2014 Section 5.4 item 8).

#### D.2.1.7. Tagged Opcodes Replacement

The BPACR shall support tagged opcodes replacement as specified in CEA-2014 Section 5.4 item 9).

#### D.2.1.8. data:// URI Scheme

The BPACR shall support the data:// URI scheme as specified in CEA-2014 Section 5.4 item 10).

#### D.2.1.9. Key Events

The BPACR shall support key events as specified in CEA-2014 Section 5.4.1.

#### D.2.1.10. Cookie Support

The BPACR shall support cookies as specified in CEA-2014 Section 5.9.

#### D.2.1.11. Robustness

The BPACR shall support requirements for the Remote UI Client pertaining to robustness as specified in CEA-2014 Section 5.10.

### D.2.2 User Interface Profile

CEA-2014 establishes a communication protocol whereby the RUI Server can learn the capabilities of an RUI Client by a “capability exchange.” The BPACR shall implement at least the minimum functionalities specified for the UI Profile “FULHD\_UIPROF” specified in CEA-2014 Section 5.2. These include:

- A maximum width of the browser area corresponding to the full width of the display screen.
- A maximum height of the browser area corresponding to the full width of the display screen.
- A color depth of at least 65,536 colors (“high” color).
- Support for Tiresias Screenfont font with a default font size of 36 points.
- Support for Letter Gothic 12 Pitch font with a default font size of 36 points.
- Inclusion of and support for navigation keys on the remote control unit (up, down, left, right, and ENTER).
- Inclusion of and support for numeric keys on the remote control unit.

### D.2.3 Optional Elements

Support for the following items is optional.

#### D.2.3.1. Window Scripting Object

The BPACR may or may not support window scripting methods and properties as defined in CEA-2014 Section 5.4.2.

#### D.2.3.2. In-session Notifications

The BPACR may or may not support the in-session notification methods defined in CEA-2014 Section 5.5.

#### D.2.3.3. Third-party Notifications

The BPACR may or may not support the third-party notification methods defined in CEA-2014 Section 5.6.

#### D.2.3.4. A/V Playback and Control

The BPACR may or may not support the A/V playback and control methods defined in CEA-2014 Section 5.7.

#### D.2.3.5. Save and Restore

The BPACR may or may not support the save and restore mechanism referenced in CEA-2014 Section 5.8.

#### D.2.3.6. Control Ownership

The BPACR may or may not support the control ownership mechanism referenced in CEA-2014 Section 5.11.

#### D.2.3.7. Home Network Framework

The BPACR may or may not support the home network framework referenced in CEA-2014 Section 5.12.

#### D.2.3.8. Scalable Vector Graphics (SVG)

The BPACR may or may not support web-pages containing or referencing Scalable Vector Graphics (SVG) documents as specified in CEA-2014 Section 5.15.

#### D.2.3.9. Connection Handler

The BPACR may or may not include a connection handler to support discovery and setup/control requests from a third-party remote UI control point inside a UPnP network.

#### D.2.3.10. UI Shell

The BPACR may or may not implement UI shell functionality (used to show the available UIs that are discovered within the network).

#### D.2.3.11. Download Agent

The BPACR may or may not implement a download agent for downloading content onto local storage available to the Remote UI client.

#### D.2.3.12. DRM Agent

The BPACR may or may not implement a DRM agent for managing licenses to play back (downloaded) content protected by Digital Rights Management.

#### D.2.3.13. Authentication and Authorization

The BPACR may or may not implement authentication and authorization to protect unwanted access to local device APIs made available to Remote UIs through ECMAScript.

#### D.2.3.14. Parental Control Agent

The BPACR may or may not implement a parental control agent to interchange data with the parental rating control functionality.

### **D.2.4 Summary**

Table D.1 is provided as an informative reference to illustrate the relationship between the BPACR and a CEA-2014 client in terms of optional and required elements. The listed functionalities refer to Section 4.5.1 of CEA-2014-B.

**Table D.1** Required and Optional Functionality for BPACR (Informative)

Functionality	Required/Optional	
	CEA-2014	BPACR
1. XHTML Browser	Required	Required
2. Connection Handler	Optional	Optional
3. User Input Handler	Required	Required
4. Event/Notification Handler	Required	Optional
5. 3 <sup>rd</sup> Party Notification Handler	Required	Optional
6. UI Shell	Required	Optional
7. A/V Playback	Optional	Optional
8. Save-Restore Handler	Optional	Optional
9. Download Agent	Optional	Optional
10. DRM Agent	Optional	Optional
11. Home Network Control	Optional	Optional
12. Control Ownership	Optional	Optional
13. Authentication and Authorization	Optional	Optional
14. Parental Control Agent	Optional	Optional

# Annex E

## DTS-HD File Structure

### E.1 INTRODUCTION

This Annex defines the structure of data in \*.dtsHD files.

### E.2 CHUNKS

The data shall be organized in “chunks”. Chunks can contain various types of metadata like time code, navigation pointers for VBR streams, information about the configuration of the stream etc. DTS-HD audio data stream shall be wrapped in a chunk. There are 13 different chunks defined and listed in Table E.1. Additional chunks may be added in future revisions to serve for example editing undo, in place editing, etc. Hence the applications that process \*.dtsHD files read what they are programmed to understand and skip chunks that they don't recognize.

**Table E.1** List of Defined Chunks

Chunk ID				Short Description
DTSHDHDR				DTS-HD File Header Chunk
FILEINFO				Textual Description of a File
CORESSMD				Metadata for the Core Sub-stream
Table E.9 Loudspeaker Masks				Metadata for the Extension Sub-stream(s)
Notation	Loudspeaker Location Description	Corresponding bit in nuSpkrActivityMask or nuStndrSpkrLayoutMask	Number of Channels	
C	Center in front of listener	0x0001	1	
LR	Left/Right in front	0x0002	2	
LsRs	Left/Right surround on side in rear	0x0004	2	
LFE1	Low frequency effects subwoofer	0x0008	1	
Cs	Center surround in rear	0x0010	1	
LhRh	Left/Right height in front	0x0020	2	

LsrRsr	Left/Right surround in rear	0x0040	2																									
Ch	Center Height in front	0x0080	1																									
Oh	Over the listener's head	0x0100	1																									
LcRc	Between left/right and center in front	0x0200	2																									
LwRw	Left/Right on side in front	0x0400	2																									
LssRss	Left/Right surround on side	0x0800	2																									
LFE2	Second low frequency effects subwoofer	0x1000	1																									
LhsRhs	Left/Right height on side	0x2000	2																									
Chr	Center height in rear	0x4000	1																									
LhrRhr	Left/Right height in rear	0x8000	2																									
EXTSS_MD																												
AUPR-HDR				Metadata for a Particular Audio Presentation (Several Presentations Can be Carried in One Stream)																								
AUPRINFO				Textual Description of a Particular Audio Presentation																								
NAVI-TBL				Navigation Pointers for Variable Bit Rate Streams																								
<p>Table E.14 Navigation Metadata</p> <table border="1"> <tr> <td>"NAVI-TBL" Keyword</td> <td>8 Bytes</td> <td>ASCII</td> </tr> <tr> <td>Navi_Tbl_Md_Bytes_Size</td> <td>8 Bytes</td> <td>uint8B</td> </tr> <tr> <td>Num_Entries_In_Navi_Tbl</td> <td>4 Bytes</td> <td>uint3B</td> </tr> <tr> <td>Navi_Interval_In_Frames</td> <td>2 Bytes</td> <td>uint2B</td> </tr> <tr> <td>Navi_Tbl_Entry_Byte_Size</td> <td>1 Bytes</td> <td>uint1B</td> </tr> <tr> <td colspan="3">The Table With Num_Entries_In_Navi_Tbl Entries Of Type Described By Offset_In_Bytes_To_Raccsp (Random Access Point)</td> </tr> <tr> <td>Offset_In_Bytes_To_Raccsp</td> <td>Navi_Tbl_Entry_Byte_Size number Bytes</td> <td>uintXB</td> </tr> <tr> <td>Reserved</td> <td>unspecified number</td> <td>unspecified type</td> </tr> </table>				"NAVI-TBL" Keyword	8 Bytes	ASCII	Navi_Tbl_Md_Bytes_Size	8 Bytes	uint8B	Num_Entries_In_Navi_Tbl	4 Bytes	uint3B	Navi_Interval_In_Frames	2 Bytes	uint2B	Navi_Tbl_Entry_Byte_Size	1 Bytes	uint1B	The Table With Num_Entries_In_Navi_Tbl Entries Of Type Described By Offset_In_Bytes_To_Raccsp (Random Access Point)			Offset_In_Bytes_To_Raccsp	Navi_Tbl_Entry_Byte_Size number Bytes	uintXB	Reserved	unspecified number	unspecified type	Instructions to a Post-processing Tool About the Number of Bits to be Removed from the LSB part of Lossless Stream at Particular Frame Index
"NAVI-TBL" Keyword	8 Bytes	ASCII																										
Navi_Tbl_Md_Bytes_Size	8 Bytes	uint8B																										
Num_Entries_In_Navi_Tbl	4 Bytes	uint3B																										
Navi_Interval_In_Frames	2 Bytes	uint2B																										
Navi_Tbl_Entry_Byte_Size	1 Bytes	uint1B																										
The Table With Num_Entries_In_Navi_Tbl Entries Of Type Described By Offset_In_Bytes_To_Raccsp (Random Access Point)																												
Offset_In_Bytes_To_Raccsp	Navi_Tbl_Entry_Byte_Size number Bytes	uintXB																										
Reserved	unspecified number	unspecified type																										

	Bytes		
Dword_Align	1, 2, or 3 Bytes	Filled with 0's	
End Of Navigation Table			
Reserved	unspecified number Bytes	unspecified type	
Dword_Align	1, 2, or 3 Bytes	Filled with 0's	
<b>BITSHVTB</b>			
STRMDATA			DTS-HD Stream Audio Data
TIMECODE			Time-code Metadata
BUILDVER			DTS-HD Encoder Version Identification
BLACKOUT			DTS-HD Silence Audio Frame Data
BRANCHPT			Markers for Branch Point Entry

Note: Only the content of the STRMDATA chunk is destined for authoring to a file.

### E.2.1 Chunk Parsing

All chunks shall be comprised of

- An 8 byte ASCII header identifier
- An 8 byte size field
- A payload
- A reserved field to allow for expansion of the payload
- Zero byte padding to ensure the next chunk commences on a DWORD boundary.

The 8 byte ASCII field exclusively identifies the chunk.

The 8 byte size field shall be inclusive of the payload, reserved field and zero byte padding and shall not include 8 byte ASCII header identifier nor 8 byte size field.

### E.2.2 Chunk Order and Navigation

The DTSHDHDR chunk shall be the first chunk in the file. The remaining chunks can occur in any order.

Applications that open .dtshd files shall check for the presence of “DTSHDHDR” in the first 8 bytes of the file.

After finding the DTSHDHDR keyword, the next 8 byte field that indicates the size of DTSHDHDR chunk (Hdr\_Byte\_Size Bytes) shall be read. The search for a particular chunk shall begin:

- First the DTSHDHDR chunk shall be skipped by traversing Hdr\_Byte\_Size bytes forward.
- Next the 8-byte ASCII chunk header identifier, found at the first 8-byte field of the second chunk, shall be compared to the desired chunk keyword and if they are matching we have found our desired chunk.

- If the match is not established the next 8-byte field that indicates the size of a current chunk (Curr\_Chunk\_Byte\_Size) is read, and then skip to the next chunk by traversing forward by Curr\_Chunk\_Byte\_Size bytes. This procedure shall be repeated until desired ASCII chunk header identifier is found.

### E.2.3 Chunk Notation

- ASCII indicates ASCII coded 8-bit characters
- uintNB indicates N-Byte unsigned integers in the range from 0 to  $2^{N*8} - 1$
- barray2B indicates a 2-Byte array where each bit is treated as a Boolean variable

### E.2.4 DTSHDHDR

This shall be the first chunk in a .dtshd formatted file.

**Table E.2** DTS-HD File Organization

"DTSHDHDR" Keyword	8 Bytes	ASCII
Hdr_Byte_Size	8 Bytes	uint8B
Hdr_Version	4 Bytes	uint4B
Time_Code	5 Bytes	uint5B
TC_Frame_Rate	1 byte	uint1B
Bitw_Stream_Metadata	2 Bytes	barray2B
Num_Audio_Presentations	1 Byte	uint1B
Number_Of_Ext_Sub_Streams	1 Byte	uint1B
End Of DTSHDHDR Header		
Reserved	unspecified number Bytes	unspecified type
Dword_Align	1, 2, or 3 Bytes	Filled with 0's

The time code data shall be a 40-bit field composed as follows:

**Table E.3** Time\_Code Data

Bits 39 to 38	Bits 32 to 37	Bits 0 to 31
RefClockCode	Reserved	TimeStamp

**Table E.4** Reference Clock Period

RefClockCode	Clock (Hz)
0	32000.0
1	44100.0
2	48000.0
3	reserved

The TimeStamp value represents the sample count since midnight. This number is a function of the elapsed time and the sample frequency as indicated by (RefClockCode) from Table E.3. The equation for conversion of the number of video frames to the TimeStamp value shall be:

$$TimeStamp = \text{floor} \left( \frac{NumVideoFrames * clock}{VideoRate} \right)$$

Where NumVideoFrames is the timecode expressed as the frame count since midnight, clock shall be the value of the timecode sample rate as indicated in Table E.3 and the VideoRate shall be 23.976, 24, 25, 29.97 or 30 frames per second. Since DTSHD files have a constant delay of two frames the TimeStamp corresponds to the start of the first sample obtained by decoding the third frame in the file.

The TC\_Frame\_Rate field shall be composed as follows:

**Table E.5 TC\_Frame\_Rate Code**

TC_Frame_Rate	Timecode Rate
xxxx 0000	NOT_INDICATED
xxxx 0001	23.97602398...
xxxx 0010	24.0
xxxx 0011	25.0
xxxx 0100	29.97002997... DROP
xxxx 0101	29.97002997...
xxxx 0110	30.0 DROP
xxxx 0111	30.0
xxxx 1000 to xxxx 1111	RESERVED

The Bitw\_Stream\_Metadata field shall be composed as follows:

**Table E.6** Bitw\_Stream\_Metadata Bit Fields Syntax

Field Description	Bit Location
Constant bit-rate (CBR) or variable bit-rate (VBR) stream descriptor: - CBR if FALSE - VBR if TRUE	0x0001
Peak bit rate smoothing (PBRs) indicator: - PBRs has not been performed if FALSE - PBRs has been performed if TRUE	0x0002
Navigation table indicator: - navigation data is not embedded in the header if FALSE - navigation data is embedded in the header if TRUE	0x0004
Presence of a core sub-stream: - Not present if FALSE - Present if TRUE	0x0008
Presence of an extension sub-stream(s): - Not present if FALSE - Present if TRUE	0x0010
Reserved	0x0020 – 0x8000

A DTS-HD stream may consist of core sub-stream and/or up to four extension sub-streams. The actual number of extension sub-streams (Num\_ExSS) present in the stream shall be calculated as follows:

```

if ( (Bitw_Stream_Metadata & 0x0010) == TRUE)
  Num_ExSS = Number_Of_Ext_Sub_Streams+1
else
  Num_ExSS = 0

```

### E.2.5 FILEINFO

Contains abbreviated textual information regarding the file that in certain OS's shall be of value in a popup window.

**Table E.7** FILEINFO Metadata

"FILEINFO" Keyword	8 Bytes	ASCII
FILEINFO_Text_Byte_Size	8 Bytes	uint8B
A null terminated ASCII string containing a textual description of the file. (i.e., VBR or CBR file; Primary and/or Secondary Audio ...)		ASCII
Reserved	unspecified number Bytes	unspecified type
Dword_Align	1, 2, or 3 Bytes	Filled with 0's

## E.2.6 CORESSMD

**Table E.8** Core Sub-Stream Metadata

"CORESSMD" Keyword	8 Bytes	ASCII
Core_Ss_Md_Bytes_Size	8 Bytes	uint8B
Core_Ss_Max_Sample_Rate_Hz	3 Bytes	uint3B
Core_Ss_Bit_Rate_Kbps	2 Bytes	uint2B
Core_Ss_Channel_Mask	2 Bytes	array2B
Core_Ss_Frame_Payload_In_Bytes	4 Bytes	uint4B
Reserved	unspecified number Bytes	unspecified type
Dword_Align	1, 2, or 3 Bytes	Filled with 0's

The parameter `Core_Ss_Channel_Mask` indicates which of the pre-defined loudspeaker positions apply to the audio channels encoded in Core Sub-stream. Each encoded channel or channel pair, depending on the corresponding speaker position(s), sets the appropriate bit in a loudspeaker activity mask. Predetermined loudspeaker positions are described in Table E.8, which follows. For example, `Core_Ss_Channel_Mask = 0xF` indicates activity of C, L, R, L<sub>s</sub>, R<sub>s</sub> and LFE<sub>1</sub> loudspeakers.

**Table E.9** Loudspeaker Masks

Notation	Loudspeaker Location Description	Corresponding bit in nuSpkrActivityMask or nuStndrSpkrLayoutMask	Number of Channels
C	Center in front of listener	0x0001	1
LR	Left/Right in front	0x0002	2
L <sub>s</sub> R <sub>s</sub>	Left/Right surround on side in rear	0x0004	2
LFE <sub>1</sub>	Low frequency effects subwoofer	0x0008	1
C <sub>s</sub>	Center surround in rear	0x0010	1
L <sub>h</sub> R <sub>h</sub>	Left/Right height in front	0x0020	2
L <sub>sr</sub> R <sub>sr</sub>	Left/Right surround in rear	0x0040	2
C <sub>h</sub>	Center Height in front	0x0080	1
O <sub>h</sub>	Over the listener's head	0x0100	1
L <sub>c</sub> R <sub>c</sub>	Between left/right and center in front	0x0200	2
L <sub>w</sub> R <sub>w</sub>	Left/Right on side in front	0x0400	2
L <sub>ss</sub> R <sub>ss</sub>	Left/Right surround on side	0x0800	2
LFE <sub>2</sub>	Second low frequency effects subwoofer	0x1000	1
L <sub>hs</sub> R <sub>hs</sub>	Left/Right height on side	0x2000	2
C <sub>hr</sub>	Center height in rear	0x4000	1
L <sub>hr</sub> R <sub>hr</sub>	Left/Right height in rear	0x8000	2

**E.2.7 EXTSS\_MD****Table E.10** Extension Sub-Stream Metadata

"EXTSS_MD" Keyword	8 Bytes	ASCII
Ext_Ss_Md_Bytes_Size	8 Bytes	uint8B
Ext_Ss_Avg_Bit_Rate_Kbps	3 Bytes	uint3B
The Following Two Fields Are Present Only If (Bitw_Stream_Metadata & 0x0001) == TRUE		
Ext_Ss_Peak_Bit_Rate_Kbps	3 Bytes	uint3B
Pbr_Smooth_Buff_Size_Kb	2 Bytes	Uint2B
End Of Fields That Are Conditional On (Bitw_Stream_Metadata & 0x0001) == TRUE		
The Following Field Is Present Only If (Bitw_Stream_Metadata & 0x0001) == FALSE		
Ext_Ss_Frame_Payload_In_Bytes	4 Bytes	uint4B
End Of Field That Is Conditional On (Bitw_Stream_Metadata & 0x0001) == FALSE		
Reserved	unspecified number Bytes	unspecified type
Dword_Align	1, 2, Or 3 Bytes	Filled with 0's

All Num\_ExSS extension sub-streams, that are present in the stream, are described together as group using the EXTSS\_MD chunk. Consequently:

- the Ext\_Ss\_Avg\_Bit\_Rate\_Kbps is the average bit rate of data in all extension sub-streams together
- the Ext\_Ss\_Frame\_Payload\_In\_Bytes this field exist only for the constant bit rate (CBR) streams and it indicates the frame payload of all extension sub-stream frame payloads added together
- the Ext\_Ss\_Peak\_Bit\_Rate\_Kbps this field exists only for the variable bit rate streams (VBR) and it indicates the peak data rate when considering all extension sub-streams coexisting together; Note that even in the case when only one of the extension sub-streams is VBR and all others are CBR the stream is considered to be VBR.

## E.2.8 AUPR-HDR

**Table E.11** Audio Presentation Header Metadata

"AUPR-HDR" Keyword	8 Bytes	ASCII
Audio_Pres_Hdr_Md_Bytes_Size	8 Bytes	uint8B
Audio_Pres_Index	1 Bytes	uint1B
Bitw_Aupres_Metadata	2 Bytes	barray2B
Max_Sample_Rate_Hz	3 Bytes	uint3B
Num_Frames_Total	4 Bytes	uint4B
Samples_Per_Frame_At_Max_Fs	2 Bytes	uint2B
Num_Samples_Orig_Audio_At_Max_Fs	5 Bytes	uint5B
Channel_Mask	2 Bytes	barray2B
Codec_Delay_At_Max_Fs	2 Bytes	uint2B
The Following Three Fields Are Present Only If (Bitw_Aupres_Metadata & 0x0003) == 3		
BC_Core_Max_Sample_Rate_Hz	3 Bytes	uint3B
BC_Core_Bit_Rate_Kbps	2 Bytes	uint2B
BC_Core_Channel_Mask	2 Bytes	barray2B
End of fields that are conditional on (Bitw_Aupres_Metadata & 0x0003) == 3		
The Following Field Is Present Only If (Bitw_Aupres_Metadata & 0x0004) == true		
LSB_Trim_Percent	1 Byte	uint1B
End of fields that are conditional on (Bitw_Aupres_Metadata & 0x0004) == true		
Reserved	unspecified number Bytes	unspecified type
Dword_Align	1, 2, or 3 Bytes	Filled with 0's

Note: Authoring tools shall use the `Codec_Delay_At_Max_Fs` and the `Samples_Per_Frame_At_Max_Fs` to determine the number of encoded frames that initially must to be skipped (i.e., excluded from the disc). In particular this number of skipped frames denoted by the `NumFramestoSkipp` shall be calculated as:

$$\text{NumFramestoSkipp} = \frac{\text{Codec\_Delay\_At\_Max\_Fs} + \frac{\text{Samples\_Per\_Frame\_At\_Max\_Fs}}{2}}{\text{Samples\_Per\_Frame\_At\_Max\_Fs}}$$

Where all variables shall be integer types and all divisions shall be integer operations. It is easy to see that the `NumFramestoSkipp` represents the integer number of frames such that the `NumFramestoSkipp*Samples_Per_Frame_At_Max_Fs` is the closest to `Codec_Delay_At_Max_Fs`. The first `NumFramestoSkipp`, of audio frames from any `dtshd` file must be skipped and not placed on an authored disc.

Bits in the `Bitw_Aupres_Metadata` field indicate whether an audio presentation contains:

- Backward compatible Coherent Acoustics coding component
- Lossless coding component
- Low bit-rate (LBR) coding component

In the case of a stream with multiple presentations a backward compatible core component shall reside in either core sub-stream or extension sub-stream. This is also indicated by bits of the Bitw\_Aupres\_Metadata field. The Bitw\_Aupres\_Metadata field shall be composed as follows:

**Table E.12** Bitw\_Aupres\_Metadata Bit Fields Syntax

Field Description	Bit Location
Presence of a backward compatible core coding component: - Not present if FALSE - Present if TRUE	0x0001
Location of a backward compatible core coding component: - Located in the core sub-stream if FALSE - Located in the extension sub-stream if TRUE  This field has no meaning if the value of BITW_AUPRES_METADATA & 0x0001 is FALSE	0x0002
Presence of a lossless coding component: - Not present if FALSE - Present if TRUE	0x0004
Presence of a LBR coding component: - Not present if FALSE - Present if TRUE	0x0008
Reserved	0x0010 – 0x8000

The parameter Channel\_Mask indicates which of the pre-defined loudspeaker positions apply to the audio channels encoded in the specific audio presentation of the extension sub-stream. Each encoded channel or channel pair, depending on the corresponding speaker position(s), sets the appropriate bit in a loudspeaker activity mask. Predetermined loudspeaker positions are described in Table E.8. For example, Channel\_Mask = 0x27 indicates activity of C, L, R, L<sub>s</sub>, R<sub>s</sub>, L<sub>h</sub>, and R<sub>h</sub> loudspeakers.

The parameter BC\_Core\_Channel\_Mask indicates which of the pre-defined loudspeaker positions apply to the audio channels encoded in backward compatible core components for the the specific audio presentation. Each encoded channel or channel pair, depending on the corresponding speaker position(s), sets the appropriate bit in a loudspeaker activity mask. Predetermined loudspeaker positions are described in Table E.8.

## E.2.9 AUPRINFO

**Table E.13** Audio Presentation Information Text

“AUPRINFO” Keyword	8 Bytes	ASCII
Audio_Pres_Info_Text_Byte_Size	8 Bytes	uint8B
Audio_Pres_Info_Text_Index	1 Bytes	uint1B
Reserved	unspecified number of ASCII characters	ASCII
Dword_Align	0, 1, 2, or 3 Bytes	Filled with 0's
End Of Audio Presentation Information Text		
Reserved	unspecified number Bytes	unspecified type
Dword_Align	1, 2, or 3 Bytes	0's

**E.2.10 NAVI-TBL****Table E.14** Navigation Metadata

"NAVI-TBL" Keyword	8 Bytes	ASCII
Navi_Tbl_Md_Bytes_Size	8 Bytes	uint8B
Num_Entries_In_Navi_Tbl	4 Bytes	uint3B
Navi_Interval_In_Frames	2 Bytes	uint2B
Navi_Tbl_Entry_Byte_Size	1 Bytes	uint1B
The Table With Num_Entries_In_Navi_Tbl Entries Of Type Described By Offset_In_Bytes_To_Raccsp (Random Access Point)		
Offset_In_Bytes_To_Raccsp	Navi_Tbl_Entry_Byte_Size number Bytes	uintXB
Reserved	unspecified number Bytes	unspecified type
Dword_Align	1, 2, or 3 Bytes	Filled with 0's
End Of Navigation Table		
Reserved	unspecified number Bytes	unspecified type
Dword_Align	1, 2, or 3 Bytes	Filled with 0's

**E.2.11 BITSHVTB****Table E.15** Bit Shaving Metadata

"BITSHVTB" Keyword	8 Bytes	ASCII
Bit_Shave_Tbl_Md_Bytes_Size	8 Bytes	uint8B
Bit_Shave_Audio_Pres_Index	1 Byte	uint1B
Num_Entries_In_Bitshave_Tbl	4 Bytes	uint3B
The Table With Num_Entries_In_Bitshave_Tbl Data Pairs Of Type Described By (Bitshv_Frame_Index, Num_Bits_To_Shave)		
Frame_Index_To_Change_Bitshv	4 Bytes	uint4B
Num_Bits_To_Shave	1 Bytes	uint1B
Reserved	unspecified number Bytes	unspecified type
Dword_Align	1, 2, or 3 Bytes	Filled with 0's
End Of Bit Shaving Table		
Reserved	unspecified number Bytes	unspecified type
Dword_Align	1, 2, or 3 Bytes	Filled with 0's

**E.2.12 STRMDATA**

The payload of the STRMDATA chunk is destined for authoring use.

**Table E.16** DTS-HD Encoded Stream Data

"STRMDATA" Keyword	8 Bytes	ASCII
Stream_Data_Byte_Size	8 Bytes	uint8B
DTS-HD Encoded Stream Data (for the specific format see DTS-HD stream specifications)		uint8B
Reserved	unspecified number Bytes	unspecified type
Dword_Align	1, 2, or 3 Bytes	Filled with 0's

**E.2.13 TIMECODE****Table E.17** DTS-HD Timecode Data

"TIMECODE" Keyword	8 Bytes	ASCII
Timecode_Data_Byte_Size	8 Bytes	uint8B
Timecode Clock	4 Bytes	uint4B
Timecode Frame Rate	1 Bytes	uint1B
Start samples since midnight	8 Bytes	uint8B
Start Residual	4 Bytes	uint3B
Reference samples since midnight	8 Bytes	uint8B
Reference Residual	4 Bytes	uint3B
Reserved	unspecified number Bytes	unspecified type
Dword_Align	1, 2, or 3 Bytes	Filled with 0's

The TIMECODE chunk contains the samples since midnight and reference time positions.

Timecode Clock – the sample frequency used to evaluate samples since midnight.

Timecode Frame Rate – see DTSHDHDR TC\_Frame\_Rate in Table E.4.

**E.2.14 BUILDVER****Table E.18** DTS-HD BuildVer Data

"BUILDVER" Keyword	8 Bytes	ASCII
BuildVer_Data_Byte_Size	8 Bytes	uint8B
A null terminated ASCII string containing a textual description of compiler information.		ASCII
Reserved	unspecified number Bytes	unspecified type
Dword_Align	1, 2, or 3 Bytes	Filled with 0's

**E.2.15 BLACKOUT****Table E.19** DTS-HD Encoded Blackout Data

"BLACKOUT" Keyword	8 Bytes	ASCII
Blackout Data_Byte_Size	8 Bytes	uint8B
DTS-HD Encoded Stream Silence Frame Data (for the specific format see DTS-HD stream specifications)		uint8B
Reserved	unspecified number Bytes	unspecified type
Dword_Align	1, 2, or 3 Bytes	Filled with 0's

**E.2.16 BRANCHPT****Table E.20** Branch Point Metadata

"BRANCHPT" Keyword	8 Bytes	ASCII
Branch_Point_Tbl_Md_Bytes_Size	8 Bytes	uint8B
Num_Entries_In_Branch_Point_Tbl	4 Bytes	uint3B
Branch_Point_Tbl_Entry_Byte_Size	1 Bytes	uint1B
The Table With Num_Entries_In_Branch_Point_Tbl Entries Of Type Described By Branch_Point_Frame_Index (Frm Index of branch point)		
<b>Branch_Point_Frame_Index</b>	Branch_Point_Tbl_Entry_Byte_Size Size number Bytes	uintXB
Reserved	unspecified number Bytes	unspecified type
Dword_Align	1, 2, or 3 Bytes	Filled with 0's
End Of Branch Point Table		
Reserved	unspecified number Bytes	unspecified type
Dword_Align	1, 2, or 3 Bytes	Filled with 0's

---

# ***Annex F***

## **AC-3 and E-AC-3 File Formats**

### **F.1 INTRODUCTION**

This document contains specifications of four different file formats used to store encoded AC-3 or E-AC-3 audio data. The specifications consider AC-3 and E-AC-3 files to be a sequence of *dataframes*. The syntactical content of the dataframes is as defined in ATSC A/52 2010.

For AC-3 files, each dataframe consists of an AC-3 *syncframe*. Each AC-3 syncframe is the encoded representation of 1536 audio samples.

For E-AC-3 files, each dataframe consists of an E-AC-3 *syncframe*. An E-AC-3 syncframe may represent 256, 512, 768 or 1536 audio samples, as indicated by the numblkscod parameter in the syncframe.

The contents of the first and sixth bytes of an AC-3 or E-AC-3 file shall be used to determine the dataframe (or file format) type. The value of the first byte of the file indicates the byte order of the file. The sixth byte of the file contains the 'bsid' bitstream parameter in the five most significant bits of the byte. This parameter indicates whether the file contains audio data encoded according to the AC-3 format (a bsid value of between 0x0 and 0x8), or whether the file contains audio data encoded according to the E-AC-3 format (a bsid value of between 0xB and 0x10).

### **F.2 SPECIFICATION**

The pseudo code below shows the AC-3 or E-AC-3 file to be a sequence of dataframes. The type of dataframes in the file may be determined by testing both the value of the first byte of data in the file, and the value of the 'bsid' parameter carried in the five most significant bits of the sixth byte of the file.

**Table F.1** AC-3 and E-AC-3 File Structure

Syntax
AC3_EAC3_file() {
if((initialbyte==0x0B) && (bsid ==> 0x0) && (bsid <=0x8)) {
while(!EOF) {
AC3_dataframe_type_0x0B();     // AC-3 file , Normal format, (big-endian)AC3_dataframe_type_0x0B
}
}
else if((initialbyte==0x77) && (bsid ==> 0x0) && (bsid <=0x8)) {
while(!EOF) {
AC3_dataframe_type_0x77();     // AC-3 file, PC (Byte Reversed) format, (little-endian)
}
}
else if((initialbyte==0x0B) && (bsid ==> 0xB) && (bsid <=0x10)) {
while(!EOF) {
EAC3_dataframe_type_0x0B();     // E-AC-3 file, Normal format, (big-endian)
}
}
else if((initialbyte==0x77) && (bsid ==> 0xB) && (bsid <=0x10)) {
while(!EOF) {
EAC3_dataframe_type_0x77();     // E-AC-3 file, PC (Byte Reversed) format, (little-endian)
}
}
} /* end of file */

**F.2.1 dataframe\_type\_0x0B**

AC-3 and E-AC-3 syncframes are defined as a sequence of bits of data. The length of a syncframe is always an integer multiple of 16. The first 16 bits of the syncframe is the syncword. This syncword has a value of ‘0000 1011 0111 0111’ (0x0B77), where the left (or most significant) bit is transmitted first. The AC-3 syncframe bit sequence may be converted into a byte sequence by forming bytes from each sequential set of 8-bits. The MSB of byte 0 is bit 0 in the AC-3 syncframe, the LSB of byte 0 is bit 7, etc.

An AC-3 or E-AC-3 file of type 0x0B consists simply of the sequence of bytes which result from this conversion. There are no headers or time stamps. The dataframe is simply the byte sequence representation of the AC-3 or E-AC-3 syncframes.

AC-3 or E-AC-3 stream:                    byte 0, byte 1, byte 2, byte 3, byte 4, byte 5...

AC-3 or E-AC-3 file type 0x0B:         byte 0, byte 1, byte 2, byte 3, byte 4, byte 5 ...

**Table F.2** Dataframe Type 0x0B

Syntax			
Field	Bytes	Value	Comments
dataframe_type_0x0B() {			
syncframe();			AC-3 or E-AC-3 syncframe
}			End of this dataframe

**F.2.2 dataframe\_type\_0x77**

An AC-3 or E-AC-3 file type 0x77 is identical to the file type 0x0B, except that pairs of bytes are reversed. The first byte in this file is the second byte of the AC-3 or E-AC-3 byte stream.

This file type is generated by some encoders running on Intel computers, and which form the AC-3 or E-AC-3 bit stream as a sequence of 16-bit words which are written to disc as 16-bit integers.

AC-3 or E-AC-3 stream:                    byte 0, byte 1, byte 2, byte 3, byte 4, byte 5...

AC-3 or E-AC-3 file of type 0x77:    byte 1, byte 0, byte 3, byte 2, byte 5, byte 4, ...

**Table F.3** Dataframe Type 0x77

<b>Syntax</b>			
<b>Field</b>	<b>Bytes</b>	<b>Value</b>	<b>Comments</b>
dataframe_type_0x77() {			
<b>syncframe()</b> ;			AC-3 or E-AC-3 syncframe in byte-pair reversed order
}			End of this dataframe