



ATSC

ADVANCED TELEVISION
SYSTEMS COMMITTEE

ATSC Standard for Transmitter Synchronization

Doc. A/110:2011
8 April 2011

Advanced Television Systems Committee
1776 K Street, N.W., Suite 200
Washington, D.C. 20006
202-872-9160

The Advanced Television Systems Committee, Inc., is an international, non-profit organization developing voluntary standards for digital television. The ATSC member organizations represent the broadcast, broadcast equipment, motion picture, consumer electronics, computer, cable, satellite, and semiconductor industries.

Specifically, ATSC is working to coordinate television standards among different communications media focusing on digital television, interactive systems, and broadband multimedia communications. ATSC is also developing digital television implementation strategies and presenting educational seminars on the ATSC standards.

ATSC was formed in 1982 by the member organizations of the Joint Committee on InterSociety Coordination (JCIC): the Electronic Industries Association (EIA), the Institute of Electrical and Electronic Engineers (IEEE), the National Association of Broadcasters (NAB), the National Cable Telecommunications Association (NCTA), and the Society of Motion Picture and Television Engineers (SMPTE). Currently, there are approximately 160 members representing the broadcast, broadcast equipment, motion picture, consumer electronics, computer, cable, satellite, and semiconductor industries.

ATSC Digital TV Standards include digital high definition television (HDTV), standard definition television (SDTV), data broadcasting, multichannel surround-sound audio, and satellite direct-to-home broadcasting.

Note: The user's attention is called to the possibility that compliance with this standard may require use of an invention covered by patent rights. By publication of this standard, no position is taken with respect to the validity of this claim or of any patent rights in connection therewith. One or more patent holders have, however, filed a statement regarding the terms on which such patent holder(s) may be willing to grant a license under these rights to individuals or entities desiring to obtain such a license. Details may be obtained from the ATSC Secretary and the patent holder.

Table of Contents

1.	SCOPE	8
1.1	Introduction and Background	8
1.2	Application	8
1.3	Organization	9
2.	REFERENCES	10
2.1	Normative References	10
2.2	Informative References	10
3.	DEFINITIONS	10
3.1	Compliance Notation	11
3.2	Treatment of Syntactic Elements	11
3.3	Reserved Fields	11
3.4	Acronyms and Abbreviations	11
3.5	Terms	12
4.	TERRESTRIAL TRANSMITTER SYNCHRONIZATION ARCHITECTURE.....	14
4.1	Elements of 8-VSB Transmission	14
4.1.1	Data Randomization	14
4.1.2	Reed Solomon ECC	15
4.1.3	Byte Interleaving	15
4.1.4	Bit Interleaving	15
4.1.5	Pre-Coding	15
4.1.6	Trellis Coding	15
4.2	Elements of M/H Transmission	16
4.2.1	ATSC M/H Data Structure	16
4.2.2	ATSC M/H Transmission System	17
4.2.3	Single-Frequency Networks (SFNs)	21
4.3	Time Considerations	21
4.3.1	Measuring Time	21
4.3.2	Specifying Time	22
4.3.3	Controlling Time	23
4.4	Single Frequency Networks	24
4.4.1	Multiple Transmitters Sharing a Single Channel	24
4.4.2	Receiver Requirements	24
4.4.3	Transmitter Requirements	24
4.4.4	Forms of Transmission Architecture	24
4.5	Distributed Transmission Concept (Transmitter Diversity)	25
4.5.1	Difference from On-Channel Repeaters	25
4.5.2	Direct Feed to Each Transmitter	25

4.5.3	Multiplicity of Delivery Methods	25
4.5.4	Transmission of Identical Symbols	26
4.5.5	Delay Spread Control	26
4.6	Synchronization Requirements	26
4.6.1	Frequency Synchronization	26
4.6.2	Data Frame Synchronization	27
4.6.3	Pre-Coding/Trellis Coding Synchronization	27
4.7	Transmitter Synchronization Mechanisms	27
4.7.1	Transmission Adapter at Source	28
4.7.2	Slave Synchronization of Transmitters	28
4.7.3	External Time and Frequency Reference	28
4.8	Distributed Translator Synchronization Mechanisms	28
4.8.1	Transmission Adapter at Source	29
4.8.2	Slave Synchronization of Translators	31
4.8.3	External Time and Frequency Reference	31
5.	SYNCHRONIZATION OF CADENCE SYNC POINTS AND M/H FRAMES	31
5.1	Calculation of Cadence Sync Point Positions	31
5.2	Calculation of M/H Frame and Sub-Structure Boundary Points	32
5.3	Calculation of CSP Back-Timing for AT Tick Alignment	32
6.	TRANSMITTER CONTROL PACKET STRUCTURE	33
6.1	Operations and Maintenance Packet Structure	34
6.1.1	Transport Header Constraints	34
6.1.2	Operations and Maintenance Packet Payload Structure	34
6.2	Transmitter Control Packets	35
6.3	Trellis Code State Data	39
6.3.1	State of Trellis at Next Data Field Start	40
6.3.2	Format	40
6.4	Transmitter Timing Control Data	41
6.4.1	Synchronization Time Stamp (STS)	43
6.4.2	Maximum Delay (MD)	43
6.4.3	Transmitter and Antenna Delay (TAD)	43
6.4.4	Offset Delay (OD)	44
6.4.5	CSP Modulation and Reference Emission Times	44
6.4.6	Determining Transmitter Delay	44
6.5	Transmitter Identification and Signaling	45
6.5.1	Transmitter and Network Identification Signaling	45
6.5.2	Transmitter Data Signaling Control	45
6.6	Data Stream Frequency Reference	45
6.6.1	Relationship of Clock Frequency to Precise Frequency Reference	46
6.6.2	Transport Stream Bit Period	46
6.7	Data Addressed to Individual Transmitters	46
6.7.1	Transmitter Addressing	47

6.7.2	Transmitter Group Indicator	47
6.7.3	Transmitter Delay Offsets	47
6.7.4	Transmitter Power Output	47
6.7.5	Transmitter Identifier Levels	47
6.8	Error Correction Coding	48
6.8.1	Reed Solomon Coding	48
7.	USE OF DUMMY DATA BYTES CHANNEL INFORMATION FOR SYNCHRONIZATION.....	48
7.1	Calculation of CSP Back-Timing for Dummy Data Bytes Channel	51
7.2	Syntax and semantics of Dummy Data Bytes Channel	51
7.3	Single Transmitter Dummy Data Byte Timing Control Data	52
8.	TRANSMITTER MODE CONTROL DATA AND SIGNALING.....	54
8.1	Field-Rate Side Channel Data	54
8.2	Field-Rate Side Channel Format	57
8.3	Bits for Data Field Sync Transmission	57
9.	TRANSMISSION ADAPTER.....	58
9.1	Model Data Processing Subsystem	61
9.1.1	All Systems Prior to Symbol Mapping	61
9.1.2	Establishes References for Transmitters	61
9.2	Transmitter Control Packet Formation	63
9.2.1	Transmission Adapter Processing	63
9.2.2	Transmitter Control Packet Pre-Processing Payload	63
9.2.3	Transmitter Control Packet Payload Substitution	64
9.2.4	Transmitter Control Packet Formation for Distributed Translators	64
9.3	Transmitter Control Packet Insertion Rate	65
9.3.1	Minimum Insertion Rate	65
9.3.2	Maximum TCP Insertion	65
9.4	Transmitter Control Packet Payload Substitution	65
9.5	Field-Rate Side Channel Construction and Insertion	66
9.5.1	Field-Rate Side Channel Insertion with No Input	66
9.6	Transport Stream Output Frequency Stability and Accuracy	67
9.7	Transport Stream Output Release Timing	67
9.8	M/H Encapsulation (MHE) Packet Identification	67
10.	TRANSMITTER SYNCHRONIZATION.....	67
10.1	Standard Modulator Functions	68
10.1.1	Data Processing	69
10.1.2	Signal Processing	69
10.2	Data Frame Cadence Synchronization	69
10.2.1	Cadence Sync Point Determination	69
10.2.2	Data Frame Synchronization	70
10.3	Transmitter Control Packet Payload Replacement	70

10.3.1	Fixed Value Packet Payload	71
10.3.2	Matches Pre-Processing Value	71
10.3.3	Traverses Transmitter Modulator	71
10.4	Trellis Code Slaving	71
10.4.1	Trellis Code State Extraction	71
10.4.2	Trellis Code State Slaving	72
10.5	Formatted Data Restoration	73
10.5.1	TCP Data Restoration	73
10.5.2	Dummy Data Bytes Channel Data Restoration	73
10.6	Transmitter Frequency Control	74
10.6.1	Symbol Clock Frequency	74
10.6.2	Pilot Frequency	74
11.	TRANSMITTER MODE CONTROL).....	74
11.1	Mode Control Data Extraction	74
11.2	VSB Mode Data Derivation	74
11.3	VSB Mode State Change Timing	75
11.4	DFS Reserved Data Derivation	75
11.5	Transmitter Reserved Data Change Timing	75
12.	TRANSMITTER TIMING ADJUSTMENT	75
12.1	Time References and Emission Time Calculations	75
12.1.1	External Precision Time Reference	76
12.2	CSP Modulation Time Alignment	76
12.2.1	STS Plus Max Delay Plus Offset Delay	76
13.	IDENTIFICATION CODE GENERATION AND TRANSMISSION	77
13.1	Code Generation	77
13.1.1	Multiple Shift Registers	77
13.1.2	Clock Rate and Phase	78
13.1.3	Preloaded Values	78
13.1.4	Synchronization with Data Field Sync	79
13.1.5	Future Enhancements	79
13.2	Code Transmission	79
13.2.1	2-VSB Signal	80
13.2.2	Symbol Synchronization	80
13.2.3	Emitted Spectrum	80
13.3	Modulation by Serial Data Stream	80
13.3.1	Modulation of RF Watermark Signal	80

Index of Tables and Figures

Table 3.1 Acronyms and Abbreviations used in this Standard	11
Table 6.1 Operations and Maintenance Packet (OMP) Organization	34
Table 6.2 Transmitter Control Packet (TCP) Organization	36
Table 6.3 Transmitter Identifier Bury Ratio	48
Table 7.1 Dummy Data Bytes Channel syntax	51
Table 8.1 Field-Rate Side Channel Data Organization	55
Table 8.2 System Mode Field Values	56
Table 8.3 Primary Communication Channel Field Values	57
Table 13.1 Code Sequence Generator Preloading	79
Figure 4.1 ATSC M/H Slot Structure	17
Figure 4.2 ATSC M/H System Overview	18
Figure 4.3 M/H Slot positioning relative to VSB data fields, showing AT Tick Alignment Point and Cadence Sync Points (CSPs) in the packet domain.	20
Figure 4.4 AT Tick Alignment Point in the symbol domain, after insertion of a data frame sync data segment at a Cadence Sync Point (CSP).	21
Figure 4.5 Relationships between Elements of GPS Time and ATSC Time ("AT Displacement" = "ATSC Time Displacement" in text).	23
Figure 4.6 Synchronized DTV transmitter block diagram.	27
Figure 4.7 Synchronized DTV translators block diagram (<i>see next page</i>).	29
Figure 6.1 Trellis coder synchronization source.	39
Figure 6.2 Trellis code interleaver synchronization source.	40
Figure 6.3 Trellis coder state byte layout.	41
Figure 6.4a Transmitter timing control relationships—reference and single transmitter case.	42
Figure 6.4b Transmitter timing control relationships—SFN case.	42
Figure 7.1 M/H Slot positioning relative to VSB data fields, showing locations of packets in which dummy byte locations are used to carry timing and control information. (Identical locations are used in each Slot but are not shown.)	49
Figure 7.2 Single transmitter timing control relationships.	53
Figure 9.1 Transmission Adapter (conceptual) [<i>see next page</i>].	59
Figure 10.1 Synchronized 8-VSB M/H transmitter channel coding.	68
Figure 10.2 Synchronized precoder, Trellis coder, and mapper.	72
Figure 10.3 Synchronized Trellis code interleaver.	73
Figure 13.1 Identification code generator (Kasami sequences).	78

ATSC Standard for Transmitter Synchronization (Doc. A/110:2011)

1. SCOPE

This document defines a standard for synchronization of multiple transmitters emitting trellis-coded 8-VSB signals in accordance with ATSC A/53 Part 2 [1] and of both single and multiple transmitters emitting Mobile DTV signals in accordance with ATSC A/153 Part 2 [5]. The emitted signals from transmitters operated according to this standard comply fully with the requirements of both ATSC A/53 and A/153. This document specifies mechanisms necessary to transmit synchronization signals to the one or several transmitters using a dedicated PID value, including the formatting of packets associated with that PID value and without altering the signal format emitted from the transmitters. It also provides for adjustment of transmitter timing and other characteristics through additional information carried in the specified packet structure. Techniques are provided for cascading transmitters in networks of synchronous translators. In addition, it specifies an alternative method for transmitting synchronization signals to single transmitters operating according to A/153.

1.1 Introduction and Background

This standard was prepared by the Advanced Television Systems Committee (ATSC) Technology Group on Distribution (T3) Specialist Group on RF Transmission (T3/S9). The document was approved by T3 on 8 October 2002 for submission by letter ballot to the membership of the Technology Group on Distribution for consideration as a Candidate Standard, as described in Section 14 of The Procedures for Technology Group and Specialists Group Operation (ATSC Doc. B/3, 21 October 2002). The document was approved by the members of T3 on 21 November 2002.

On 14 July 2004 it was approved by the full ATSC membership as ATSC Standard A/110. Corrigendum No. 1, intended to remove potential inconsistency of interpretation by different implementers of the standard, was approved on 15 June 2005. Revision A of the standard, which modified the RF watermark signal to relax the watermark data robustness by a small amount in exchange for a higher data rate, was approved on 19 July 2005. Revision B of the standard was approved by the ATSC Membership on 24 December 2007. Changes in revision B included a rollup of items contained in Corrigendum No. 1 to A/110A, which clarified certain text in Section 6 and elsewhere, and addressed outstanding editorial/format issues.

A/110:2011 was approved by TSG as a Proposed Standard on [date] and by the full ATSC Membership on [date]. A/110:2011 expanded the scope of the standard to include transmission system infrastructure considerations relating to ATSC Mobile DTV operation – specifically, the studio-to-transmitter link.

Development of the technology described herein and of this standard itself originally was carried out by the Merrill Weiss Group LLC.

1.2 Application

This document describes techniques that allow synchronization of processes between the inputs and outputs of Studio-to-Transmitter Links (STLs), that enable synchronization of transmitters to external time references, and that allow construction of *single frequency networks* (SFNs) using a multiplicity of transmitters. Both single and multiple transmitters used for Mobile DTV

transmission require synchronization of data processing between preprocessors at the STL input and post-processors in the transmitters themselves. There are two forms of transmitter systems that can be used in SFNs: *digital on-channel repeaters* (DOCRs) and *distributed transmission* (DTx) schemes including distributed transmitters (DTxTs) and distributed translators (DTxR). This document describes methods necessary to enable distributed transmission; DOCRs are beyond its scope, although perfectly valid for use in SFNs. Indeed, DOCRs can be used to extend and fill in the coverage from DTx transmitters and translators. The difference between the techniques is explained in Section 4.1.1.

Users of this standard for SFN applications are advised that, while distributed transmission holds the potential to greatly improve the coverage and service areas of DTV transmission, it also holds the potential to cause interference within the network that some receivers, particularly early designs, may not be able to handle. Consequently, distributed transmission networks must be carefully designed to minimize the burden placed on the adaptive equalizers in such legacy receivers while maximizing the improvement in signals delivered to the public. The impact on any specific receiver will depend upon the receiver's location, the use of directional receiving antennas, and other factors related to the design of the receiver.

The factors in SFN design that influence receiver performance are frequency offsets, amplitude differentials (i.e., C/I ratios), and timing differentials. Network designs may be optimized by placing areas of interference within the network in locales having low population, through use of terrain shielding, where available, by use of directional transmitting antennas, through maintenance of tight frequency control of transmitters, and by adjustment of network emission timing.

This document does not describe the hardware and physical layer protocol of connections between the outputs of equipment prior to the STL input and the STL input itself or of connections between the STL output and the inputs of equipment that follows it. It is intended that the data format described herein should operate correctly over any physical layer interface that can correctly transport MPEG-2 Transport Stream packets without modification while maintaining the necessary data rate tolerances.

1.3 Organization

The document is organized as follows:

- **Section 1** – Provides this general introduction.
- **Section 2** – Lists references and applicable documents.
- **Section 3** – Provides a definition of terms, acronyms, abbreviations, syntax formats, and code points for this document.
- **Section 4** – Describes the terrestrial transmitter synchronization architecture.
- **Section 5** – Specifies the transmitter Cadence Synchronization Points.
- **Section 6** – Specifies the Transmitter Control Packet structure.
- **Section 7** – Specifies the Dummy Data Bytes Channel structure
- **Section 8** – Specifies the data and signaling for mode control of transmitters.
- **Section 9** – Specifies the synchronization signal generation process.
- **Section 10** – Specifies the transmitter synchronization process.
- **Section 11** – Specifies the transmitter mode control methods.

- **Section 12** – Specifies the transmitter timing adjustment methods.
- **Section 13** – Specifies the generation and transmission of identification codes.

2. REFERENCES

At the time of publication, the editions indicated were valid. All referenced documents are subject to revision, and users of this Standard are encouraged to investigate the possibility of applying the most recent edition of the referenced document.

2.1 Normative References

The following documents, in whole or in part, as referenced in this document, contain provisions that are necessary to implement a mandatory or optional provision of this Standard.

- [1] ATSC: A/53, Part 2: 2007, “ATSC Digital Television Standard: RF Transmission System Characteristics,” Advanced Television Systems Committee, Washington, D.C., 3 January 2007.
- [2] ATSC: A/53, Part 3: 2007, “ATSC Digital Television Standard: Service Multiplex and Transport Subsystem Characteristics,” Advanced Television Systems Committee, Washington, D.C., 3 January 2007.
- [3] ISO/IEC 13818-1:2000, Information Technology—Generic Coding of Moving Images and Associated Audio Information: Systems.
- [4] SMPTE: “SMPTE 310M, SMPTE Standard for Television—Synchronous Serial Interface for MPEG-2 Digital Transport Stream,” Society of Motion Picture and Television Engineers, White Plains, NY.
- [5] ATSC: A/153, Part 2: 2009, "ATSC Mobile DTV Standard: RF/Transmission System Characteristics," Advanced Television Systems Committee, Washington, D.C., 15 October 2009.
- [6] ATSC: A/153, Part 3: 2009, "ATSC Mobile DTV Standard: Service Multiplex and Transport Subsystem Characteristics," Advanced Television Systems Committee, Washington, D.C., 15 October 2009.

2.2 Informative References

The following documents contain information that may be helpful in applying this Standard.

- [7] ATSC: “Guide to the ATSC Digital Television Standard,” Doc. A/54A with Corrigendum No. 1, Advanced Television Systems Committee, Washington, D.C., 4 December 2004, Corrigendum No. 1 dated 20 December 2006.
- [8] ATSC: A/111: 2009, " ATSC Recommended Practice: Design of Synchronized Multiple Transmitter Networks," Advanced Television Systems Committee, Washington, D.C., 18 September 2009.

3. DEFINITIONS

With respect to definition of terms, abbreviations, and units, the practice of the Institute of Electrical and Electronics Engineers (IEEE), as outlined in the Institute’s published standards [1], shall be used. Where an abbreviation is not covered by IEEE practice or industry practice differs from IEEE practice, the abbreviation in question is described in Section 3.3 of this

document. Definitions that are not covered by, or differ from, IEEE practice are provided in Section 3.4 herein.

3.1 Compliance Notation

This section defines compliance terms for use by this document:

shall – This word indicates specific provisions that are to be followed strictly (no deviation is permitted).

shall not – This phrase indicates specific provisions that are absolutely prohibited.

should – This word indicates that a certain course of action is preferred but not necessarily required.

should not – This phrase means a certain possibility or course of action is undesirable but not prohibited.

3.2 Treatment of Syntactic Elements

This document contains symbolic references to syntactic elements used in several subsystems. These references are typographically distinguished by the use of a different font (e.g., `restricted`) may contain the underscore character (e.g., `sequence_end_code`), and may consist of character strings that are not English words (e.g., `dynrng`).

The formats of sections and data structures in this document are described using a C-like notational method employed in ISO/IEC 13818-1 [3]. Values expressed in hexadecimal notation herein are preceded by a prefix of “0x”; thus the decimal value 123 would be denoted as “0x7B” (without the quotation marks) in hexadecimal form.

3.3 Reserved Fields

reserved – Fields in this standard marked “reserved” shall not be assigned by the user, but shall be available for future use. Any receiving device is expected to disregard reserved fields for which no definitions exist that are known to that unit. Each bit in any field marked “reserved” shall be set to one until such time as it is defined and supported.

3.4 Acronyms and Abbreviations

The following acronyms and abbreviations are used within this specification:

Table 3.1 Acronyms and Abbreviations used in this Standard

AT	ATSC Time
ATSC	Advanced Television Systems Committee
bslbf	bit serial, leftmost bit first
BSS	buried spread spectrum (direct sequence)
C/I	signal-to-interference ratio (between transmitters within a network)
CSP	cadence sync point
DBC STS	synchronization time stamp for the Dummy Data Bytes Channel
DFS	data field synchronization data segment
DS	delay spread
DTV	digital television
DTx	distributed transmission
DTxN	distributed transmission network

DTxR	distributed translator
DTxS	distributed transmission system
DTxT	distributed transmitter
D/U	desired-to-undesired signal ratio (between stations and/or networks)
ECC	error correcting code
ERP	effective radiated power
FRSC	Field Rate Side Channel
GPS	Global Positioning System
IP	Internet Protocol
lsb	least significant bit
Mb/s	megabits per second
MD	maximum delay
M/H	mobile/pedestrian/handheld
MHE	M/H Encapsulation
MPEG	Moving Picture Experts Group
msb	most significant bit
OD	offset delay
OMP	operations and maintenance packet
PAT	program association table
PCR	program clock reference
PID	packet identifier
ppm	parts per million
PRBS	pseudo random binary sequence
RF	radio frequency
riuimsbf	repeated, inverted, unsigned integer, most significant bit first
riuimsbfwp	repeated, inverted, unsigned integer, most significant bit first, with parity
SFN	single frequency network
STS	synchronization time stamp
SP	synchronization packet
RS	Reed Solomon error correcting code
TA	Transmission Adapter
TAD	transmitter and antenna delay
tcimsbf	two's complement integer, most significant bit first
TCP	transmitter control packet
TS	transport stream
uimsbf	unsigned integer, most significant bit first
uipfmsbf	unsigned integer plus fraction, most significant bit first
WM	watermark
XOR	exclusive OR function

3.5 Terms

The definitions appearing in this subsection are those that apply to terms as used in this standard and may be different from the meanings of the respective terms in other instances.

ATSC Epoch – 00:00:00 UTC on January 6, 1980, as defined in A/153 Part 2 [5].

AT Tick – An instant in time that is exactly an integer number of ATSC M/H Frame periods since the ATSC Epoch.

AT Tick Alignment Point – A location within an MPEG-2 Transport Stream at the boundary between the 37th and 38th TS packets of M/H Slot #0 of M/H Sub-Frame #0, coincident with

a Cadence Sync Point, at which an 8-VSB Data Frame Sync data segment will be inserted by the exciter and which will be emitted by the transmitter coincidentally with an AT Tick. Also, within the symbol domain, the location of the start of the first symbol of the data segment sync of the Data Frame Sync data segment inserted into the Transport Stream at the packet domain location of the AT Tick Alignment Point.

buried spread spectrum – A technique permitting carriage of data in the same spectrum with, but without interference to, another signal by transmitting that data at a much reduced level relative to the primary signal and using coding techniques to permit its recovery with adequate signal-to-noise ratio.

bury ratio – The ratio, normally expressed in dB, between the average power of a host signal and the power of a buried spread spectrum sharing the same channel.

Cadence Sync Point – A location at the boundary between two packets within an MPEG-2 Transport Stream at which an 8-VSB Data Frame Sync data segment will be inserted by the exciter. Also, within the symbol domain, the location of the start of the first symbol of the data segment sync of the Data Frame Sync data segment inserted into the Transport Stream at the packet domain location of the Cadence Sync Point.

data field – A data structure comprising 312 MPEG-2 Transport Stream packets or 313 data segments, as defined in A/53 Part 2 [1].

Data Field Sync – A data segment added by the modulator that includes mode indicators, training signals for receiver adaptive equalizers, and similar information, and that serves as the starting point for the data processing functions that start from known states. Depending upon the context, the term can apply to Data Field Sync data segments having the middle PN-63 sequence in either phase, or it can apply only to the Data Field Sync data segments that alternate with Data Frame Sync data segments.

Data Frame Sync – A Data Field Sync data segment in which the middle PN-63 sequence is not inverted relative to the two adjacent PN-63 sequences.

data segment – A part of the data framing structure, comprising 832 total symbols, that begins with a Data Segment Sync word, represented by four transmitted 2-level symbols, and carries 828 symbols of payload thereafter.

delay spread – The difference in arrival times at a point in space or at a receiver input of a signal and its significant echoes or of signals emitted by different transmitters.

Dummy Data Bytes Channel – A data communications channel that uses some or all of the 45 dummy data bytes in each M/H Group (as indicated by the value 2 in A/153 Part 2 [5], Table A.1 Group Format Before Data Interleaver) to transmit information between an M/H Preprocessor and an M/H Post Processor.

epoch – An instant in time that is defined as a reference point.

Field-Rate Side Channel – A data communications channel that uses the 312 Transport Error Indicator (TEI) bits in the headers of the 312 MPEG-2 Transport Stream packets that will constitute the payload of an 8-VSB data field to transmit information between a Transmission Adapter and one or more Transmitters.

Maximum Delay – a time period set as a parameter in a transmission system to exceed the delay from the release of data by the system's Transmission Adapter until its emission from the antenna of the transmitter having the longest Inherent delay period.

OM Packet – An MPEG-2 Transport Stream operations and maintenance packet (OMP) having an assigned PID value and carrying in its first payload byte a value indicating the format and use of the remainder of the payload data.

packet – A collection of data sent as a unit, including a header to identify and indicate other properties of the data and a payload comprising the data actually to be sent, either having a fixed, known length or having means to indicate either its length or its end.

Precursor Packet – An MPEG-2 Transport Stream packet having the PID value assigned to OM Packets, a first-byte value indicating its use for signaling control information to a specific group of transmitters, and its remaining payload bytes filled with placeholder values to enable their replacement with other values for delivery to the group of transmitters.

RF watermark – A buried spread spectrum (BSS) signal carrying codes used for the purpose of identification of the host signal with which it is associated and for carrying a small amount of low-speed data.

Synchronization Time Stamp – A value indicating the elapsed time from the last occurrence of a GPS one-second tick until the appearance in the output of a Transmission Adapter of a specific, identifiable point in the MPEG-2 Transport Stream.

Transport Stream Bit Period – The time period equal to the duration of one MPEG-2 Transport Stream bit carried at the bit rate specified for Transport Stream data in A/53 Part 3 [2] Section 8.

4. TERRESTRIAL TRANSMITTER SYNCHRONIZATION ARCHITECTURE

This section provides an overview of the ATSC trellis-coded 8-VSB (“8-VSB”) system and of the extensions applied to it to enable M/H transmission. It describes the synchronization necessary within conventional 8-VSB and M/H systems to permit their implementation using single transmitters.

This section also describes the concept of a single frequency network (SFN) and the types of transmission methods that can be used to construct an SFN. It explains the requirements for transmitters and receivers to make an SFN work, and it describes the characteristics of the 8-VSB system that must be considered when synchronizing transmitters in the distributed transmission (DTx) form of SFN. Finally, it explains the mechanisms to be used in the synchronization processes for single-transmitter M/H and both conventional 8-VSB SFN and M/H SFN operations.

4.1 Elements of 8-VSB Transmission

A conventional 8-VSB modulator comprises two basic functions: one for data processing and one for signal processing. To achieve the synchronization necessary in M/H systems between pre-processors and post-processors and in SFNs between the output symbols of transmitters that receive separate data feeds as inputs, it is necessary to synchronize the various data processing blocks of the underlying 8-VSB system. This and the following subsections examine each of those blocks in processing order, as defined in ATSC A/53 Part 2 [1], with particular reference to the timing of the operations performed by the respective blocks.

4.1.1 Data Randomization

The data randomizer (or modified data randomizer in M/H systems) exclusive-ORs (XORs) incoming data bytes with a 16-bit maximum length pseudo-random binary sequence (PRBS) that is initialized at the beginning of each Data Field. Data Fields always begin at the start of an

MPEG-2 Transport Stream (TS) packet. In unsynchronized 8-VSB, the modulator randomly selects the packet that begins a Data Field. To achieve synchronization between an M/H pre-processor and post processor pair, the first packet in an M/H frame must be identified so that the MHE packets are placed in the proper positions with respect to the 8-VSB frame structure. (See Section 4.2 below.) To achieve synchronization between transmitters in an SFN, the first packet in a Data Field must be identified so that all transmitters in a network initialize their PRBS values on the same TS packet.

4.1.2 Reed Solomon ECC

In conventional 8-VSB, the Reed Solomon (RS) error correcting code is applied individually to each packet in the transport stream. (This process is modified in M/H operation as described in Section 4.2.) Packets are processed synchronously with data segments in each Data Field. Since there is a defined phase relationship between data segments and Data Fields, there is no need for any special synchronization of the RS coding processes between M/H pre- and post-processors and between transmitters in a network; they inherently will be synchronous so long as the Data Fields are synchronized.

4.1.3 Byte Interleaving

The byte interleaver employed in the 8-VSB transmission system is a 52-data-segment (intersegment) convolutional byte interleaver. Only data bytes are interleaved. Since there are 312 active data segments in a Data Field, interleaving recurs exactly 6 times during a Data Field. The interleaver is synchronized to the first data byte of the Data Field. To achieve synchronization between M/H pre- and post-processors and between transmitters in a network, the transmitters must initialize their byte interleavers to the first data byte in each Data Field. The transmitter synchronization system provides a means for identifying these first data bytes.

4.1.4 Bit Interleaving

Intrasegment (bit) interleaving also is performed for the benefit of the trellis coding process. The bit interleaver works in conjunction with a series of 12 pre-coders and trellis coders to convert data bytes to pre-coded and trellis-coded symbols. The conversion starts with the first data segment of the Data Field and proceeds with groups of 4 data segments until the end of the Data Field. 312 active segments per Data Field divided by 4 yields 78 conversion operations per Data Field. To achieve synchronization between M/H pre- and post-processors and between transmitters in a network, the transmitters must initialize their bit interleavers on the first data byte in each Data Field, in the same way that the byte interleavers are synchronized.

4.1.5 Pre-Coding

The pre-coder is used to compensate for comb filters used in receivers for reduction of co-channel interference from NTSC signals. It has one bit of memory that carries across data segment and data field boundaries. The state of the memory at any given instant is dependent on the data that came prior to that time, with no initialization done at any time in conventional 8-VSB transmission. (Initialization performed in M/H transmission is described below in Section 4.2.) Thus, the pre-coder cannot be synchronized by identification of any element of the data signal fed to the transmitter. The method for dealing with this characteristic of the pre-coding process is described in Section 6.3.

4.1.6 Trellis Coding

The trellis coder is used to extend the reception threshold of the 8-VSB receiver by permitting use of soft-decision decoding. It has two bits of memory that carry across Data Segment and

Data Field boundaries. The state of the memory at any given instant is dependent on the data that came prior to that time, with no initialization done at any time in conventional 8-VSB transmission. (Initialization performed in M/H transmission is described below in Section 4.2.) Thus, the trellis coder cannot be synchronized by identification of any element of the data signal fed to the transmitter. The method for dealing with this characteristic of the trellis coding process is described in Section 6.3.

4.2 Elements of M/H Transmission

To set the stage for specification of the interface protocol between pre-processors and post-processors in M/H systems, in both single-transmitter and SFN configurations, this section provides an overview of the ATSC M/H extension to the 8-VSB transmission system.

4.2.1 ATSC M/H Data Structure

The ATSC M/H Standard (A/153 Part 2 [5]) defines a virtual ATSC M/H Frame structure that consists of 20 VSB Frames, having a period of about 0.968 seconds. The M/H Frame is further divided into 5 Sub-frames; each Sub-frame consists of 4 VSB Frames and carries 16 M/H Slots. An M/H Frame thus comprises 80 M/H Slots.

Each M/H Slot is equal in size to one-half of a VSB Field or one-quarter of a VSB Frame. An M/H Slot can carry M/H data (when populated by an M/H Group) plus normal data or just normal data. More specifically, each M/H Slot has a size of 156 TS packets, of which the first 118 TS packets are occupied by an M/H Group, if M/H data is being transmitted in the Slot, and the last 38 TS packets are normal data.¹ If only normal data is transmitted in a Slot, all 156 TS packets contain normal data. Data from the same Group is assigned to the same Slot in each Sub-frame of an M/H Frame.

The data structure and the relationships of its components are depicted in Figure 4.1. The figure contained herein duplicates the one found in ATSC A/153 Part 2 [5], Section 5.3.1.1, Figure 5.3, and is provided only for the convenience of the reader.

¹ The last 38 packets in a slot may be used to carry additional M/H data in future standards adopted by ATSC without affecting the applicability of this standard.

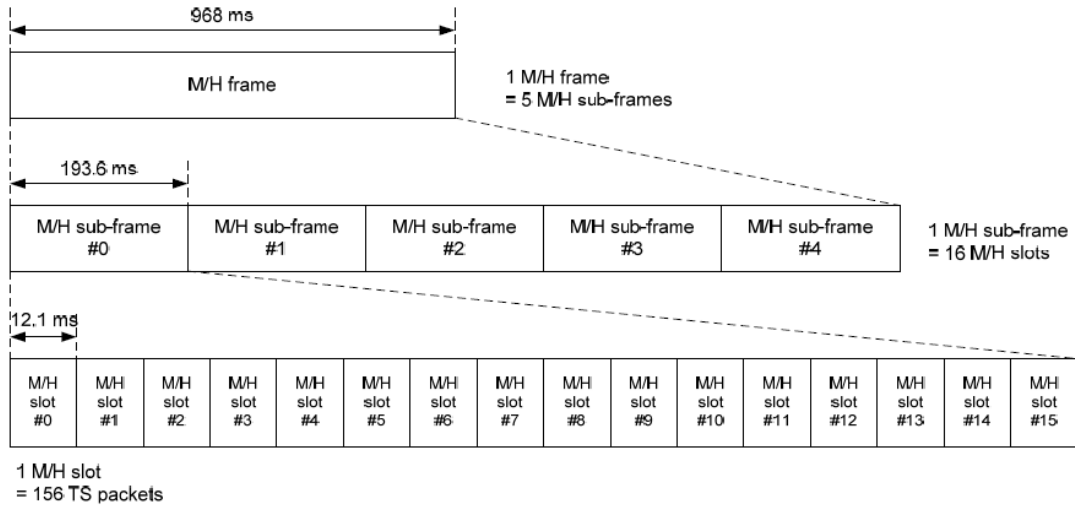

Figure 4.1 ATSC M/H Slot Structure

4.2.2 ATSC M/H Transmission System

Figure 4.2 shows an overview of the ATSC A/153 M/H transmission system. The configuration discussed in this document assumes that the functional blocks Pre-processor, Packet timing & PCR adjustment, and Packet mux are implemented in an “M/H-Multiplexer,” typically located in a studio program-release facility, while the Post-processor and RF-transmission blocks are implemented in an M/H exciter located at the transmission site(s). The link between the studio and the transmitter site(s) (the STL) typically carries an MPEG-2 Transport Stream, having a data rate of (approximately) 19.39 Mb/s, using DVB-ASI or SMPTE-310M [4] interfaces on the STL terminal equipment, although other interfaces (e.g., a dedicated Ethernet link) also can be used. It is the interface protocol transmitted across the STL that is the subject of this standard (labelled as “STL” in Figure 4.2).

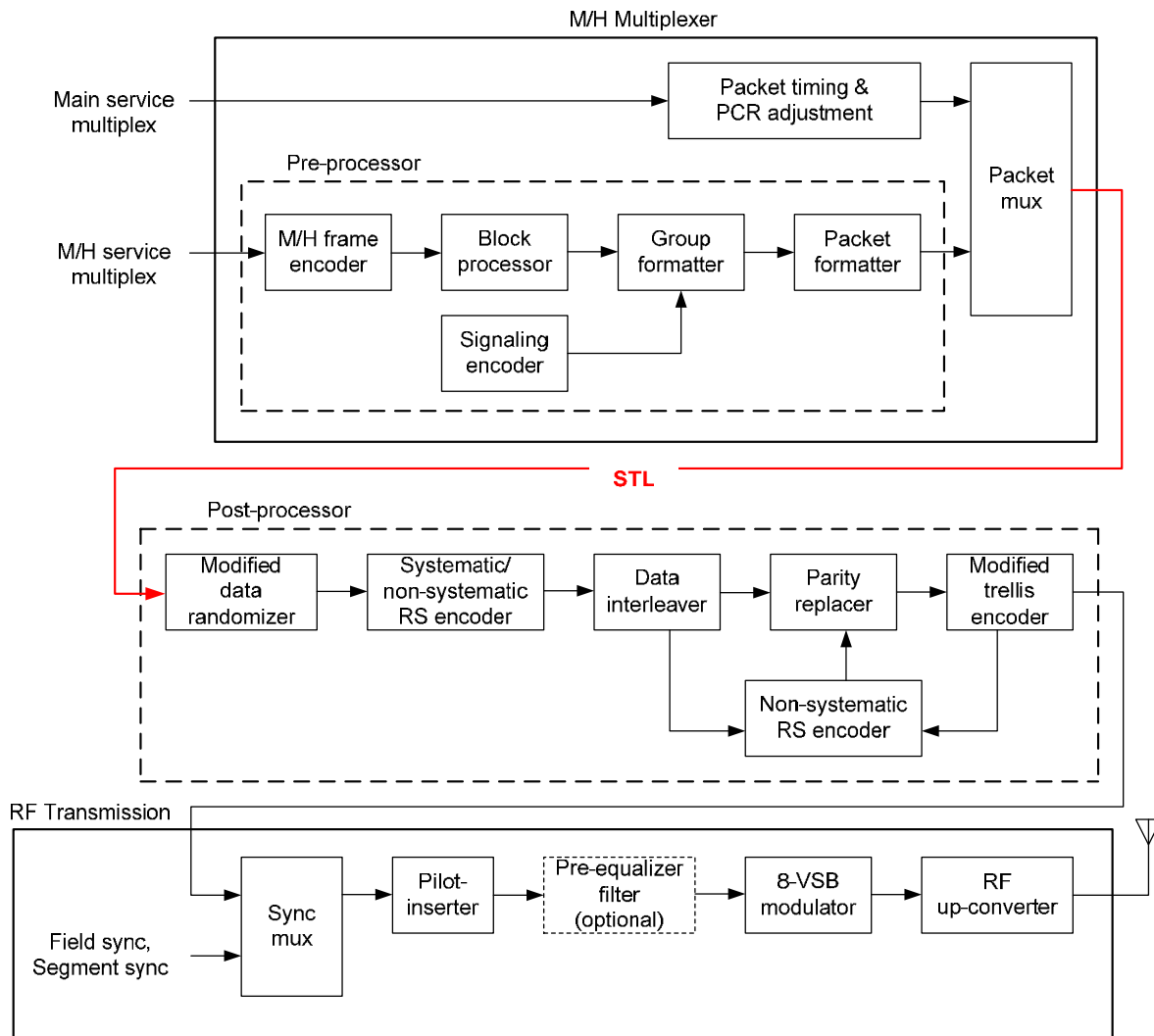

Figure 4.2 ATSC M/H System Overview

4.2.2.1 Pre-Processor

The Pre-processor forms and encodes the M/H service multiplex into RS frames, processes the RS frames into blocks, adds signalling to the blocks, forms them into Groups, and encapsulates each Group into 118 consecutive MPEG-2 Transport Stream packets (known as M/H Encapsulation [MHE] packets) having a defined PID value (which is specified in subsection 9.8 M/H Encapsulation [MHE] Packet Identification below).

4.2.2.2 Packet Timing and PCR Adjustment

The packet timing & PCR adjustment block repositions incoming MPEG-2 transport stream packets from the main service multiplexer, while maintaining the packet timing and other provisions of the ATSC Digital Television Standard (A/53), to make space available in the TS stream at the necessary locations for the insertion of MHE packets from the pre-processor.

Because it relocates packets in the stream, when necessary, it also corrects the PCR values that they contain.

Note that, in order to maintain compliance with MPEG-2 and A/53 buffer models, the original packet order (in the multiplex) may have to be changed, particularly to manage audio, and that the VBV buffer size utilized by the video encoders at the source may have to be reduced.

4.2.2.3 Packet Mux

The packet multiplexer (mux) combines the repositioned and PCR-adjusted packets of the main service MPEG-2 TS with the MHE TS packets to form a cadence of 118 MHE packets followed by 38 main stream packets. The packet mux also periodically inserts a packet, the Transmitter Control Packet (TCP), into the main service data to carry data necessary for synchronizing the operation of the post-processor(s) with that of the pre-processor. The packet mux also can insert similar data into dummy data bytes included in the MHE data structure for use in synchronization of the pre- and post-processor functions in single-transmitter configurations.

4.2.2.4 STL

The Studio-to-Transmitter Link (STL) serves as the connection to carry data between the two major portions of the system. It must have appropriate physical layer interfaces to connect to the devices at either end of the link, which interfaces are unspecified herein but typically would use DVB-ASI, SMPTE 310 [4], or equivalent methods. It is important that the STL not alter in any way the data that it carries and must deliver it bit-for-bit unchanged to the input(s) of the post-processor(s).

4.2.2.5 Post-Processor

The post-processor (typically included in the exciter) locates each M/H Group in the incoming data stream and applies special post-processing to the MHE packets, while still processing the normal ATSC main service TS packets in the conventional manner. The post processor identifies the occurrence of M/H Group data via a dedicated PID value that is used exclusively for MHE packets.

Identification of the first packet in Slot #0 in Sub-Frame #0 is accomplished using a calculation based on a combination of the values of the `packet_frame_number` and `packet_number` fields of a special Operations and Maintenance Packet (OMP), known as the Transmitter Control Packet (TCP) and defined in this standard. MHE packet #37 of Slot #0, once located, is required to be aligned to occur in the first packet position in an odd VSB data field, immediately following the point identified as the AT TickAlignment Point in the packet domain in Figure 4.3.

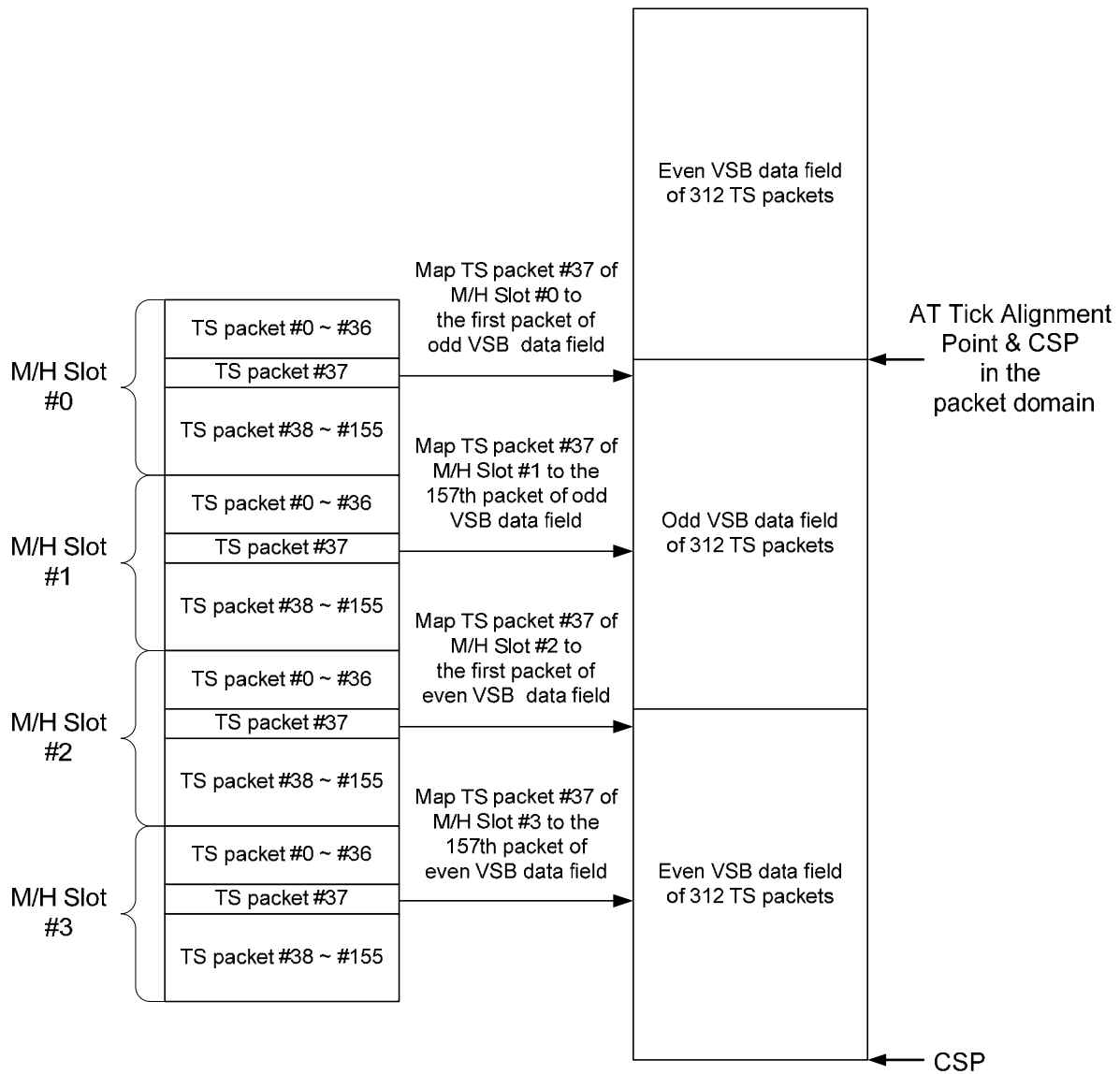

Figure 4.3 M/H Slot positioning relative to VSB data fields, showing AT Tick Alignment Point and Cadence Sync Points (CSPs) in the packet domain.

The AT Tick Alignment Point is shown in the packet domain in Figure 4.3, the basis of which is ATSC A/153 Part 2 [5], Section 5.3.1.1, Figure 5.5. An AT Tick Alignment Point occurs once every 20 CSPs, coincident with a CSP. An AT Tick Alignment Point and coincident CSP are shown in the symbol domain in Figure 4.4, which is based on ATSC A/153 Part 2 [5], Section 5.3.2.13.1, Figure 5.32.

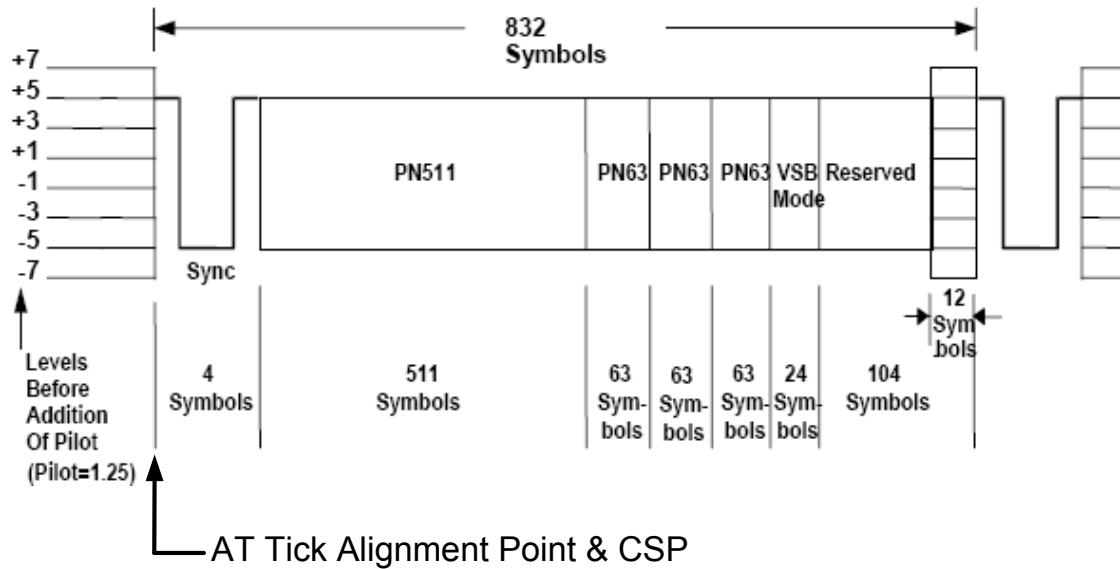

Figure 4.4 AT Tick Alignment Point in the symbol domain, after insertion of a data frame sync data segment at a Cadence Sync Point (CSP).

Note: Refer to A/153 Part 2 [5], for the normative specifications of the alignment of M/H slots with VSB frames and of the tolerances applicable to emissions relative to AT ticks.

4.2.3 Single-Frequency Networks (SFNs)

As with conventional 8-VSB, M/H single-frequency networks utilize multiple transmitters sharing a single channel to serve a common region. The transmitters emit identical signals, several of which may be received more-or-less simultaneously by individual receivers. The receivers treat the multiple received signals as echoes of one signal, extracting the data being transmitted as if it were a main signal and naturally-occurring echoes.

When ATSC transmitters (both conventional 8-VSB and M/H) are used in an SFN, additional information (as defined herein) must be delivered over the STL to permit the synchronization of all of the processes in all of the transmitters in the network so that the transmitters emit identical signals at appropriate times, as provided herein.

4.3 Time Considerations

Time is an important factor in achieving transmitter synchronization – both for 8-VSB SFNs and for M/H emitters, be they single transmitters or transmitters in networks. Time is involved in two aspects of synchronization processes: Establishing phase relationships between data frames emitted by multiple transmitters, and establishing phase relationships between data frames emitted by single or multiple transmitters and an external time reference. To establish these relationships, it is necessary to have mechanisms for measuring time, for specifying time, and for controlling time.

4.3.1 Measuring Time

Time is measured by dividing a time continuum into increments. Accurate frequency references, and, conversely, their periods, typically are derived by counting a precisely defined number of

cycles of the cesium atom resonant frequency or some similar natural phenomenon. The systems defined in this document depend upon the use of precise frequency and time references for their operation.

In the ATSC case, two related frequencies have been specified: the Transport Stream bit rate and the transmitted symbol rate. These frequencies can be converted to time increments by taking their inverses. In this standard, the period of the Transport Stream bit rate (i.e., the TS bit period) is used as the fundamental unit of time expression. Since the TS bit rate is approximately 19.39 Mb/s, the TS Bit Period time unit is the reciprocal of that value, or approximately 51.57 ns. All of these values are precisely defined herein, derived from a precise external frequency and time reference, viz. GPS.

4.3.2 Specifying Time

With the fundamental time increment defined, it becomes possible to begin specifying values that are time dependent. Examples of such time specifications are the time offsets between emissions from the transmitters within an SFN and the elapsed time between an instant – for example, a one-second clock tick – and a reference point in the Transport Stream. Information can be carried between a Transmission Adapter and a transmitter and expressed in terms of Transport Stream Bit Periods. In this document, such values are expressed as unsigned or signed binary integers.

4.3.2.1 ATSC Time

ATSC M/H transmitters in a region or in adjoining regions all broadcast their M/H frames at approximately the same time (with the only intentional differential being the time offsets applied to transmitters in an SFN), thereby providing a number of potential benefits and additional functions. Among the potential benefits are:

- Improved channel change time between services on different frequencies in the same region.
- Minimized disturbance during hand-off of services from a single service provider from one region to the next.
- The opportunity to use ATSC M/H broadcasts for geo-location by receiving devices.

The technique that permits the time alignment of signals from the transmitters of different broadcasters is known as ATSC Time (AT). Locking to ATSC Time is accomplished by synchronizing the broadcast of M/H frames to an external time reference, namely GPS Time. Such synchronization is accomplished by locking the ATSC transport stream and symbol rates to the GPS reference frequency. In addition, M/H frame boundaries are aligned with GPS Time as if the transmission had begun just prior to the GPS Epoch, so that the first CSP in the first M/H frame coincided with the GPS Epoch, and as if the transmission had run continuously since that time.

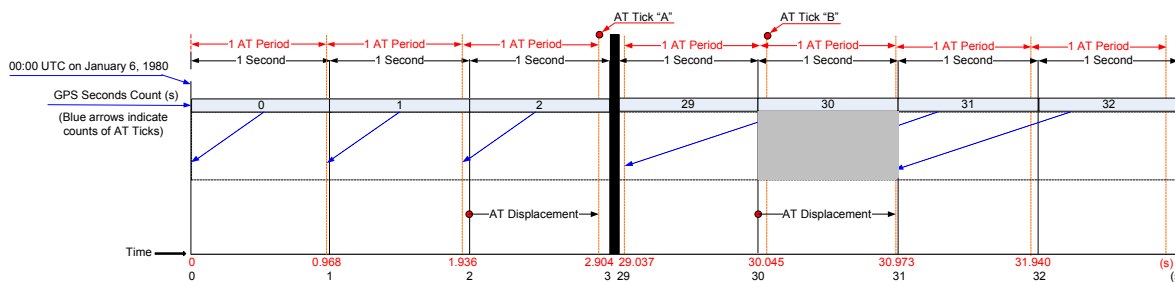

Figure 4.5 Relationships between Elements of GPS Time and ATSC Time ("AT Displacement" = "ATSC Time Displacement" in text).

The relationships between GPS Time and the M/H Frame rate and between GPS Time seconds ticks (“GPS Ticks”) and ATSC Time ticks (“AT Ticks”) are shown in Figure 4.5. In that figure, GPS seconds proceed from left to right, with the relative locations of GPS Ticks and AT Ticks shown and with AT Ticks denoted in terms of mixed-value GPS seconds. As is apparent, there are three fundamental conditions that can exist in the timing relationship between the respective ticks: The ticks can occur simultaneously, as at integer GPS second 0; there can be a single AT Tick during the interval between GPS Ticks, as between GPS Ticks 2 and 3 (labelled as AT Tick “A”); and there can be two AT Ticks during the interval between GPS Ticks, as during the interval between GPS Ticks 30 and 31 (the first of which is labelled AT Tick “B”). Note that, when GPS Ticks and AT Ticks are coincident, there will be a second AT Tick during the interval between GPS Ticks, making the relationship a special form of the third category, i.e., the category in which two AT Ticks occur between successive GPS Ticks. Also shown in the figure is the time span represented by the ATSC Time Displacement value, which is defined in Section 6.2 and carried in the `atsc_time_displacement` field.

4.3.3 Controlling Time

To control the times of occurrence of various operations and functions in 8-VSB SFNs and in M/H systems involving either single or networked transmitters, several control loops are defined or implicit in this standard. They are primarily for the purpose of permitting the time alignment of specific points in the emitted signals either with the same points in the signals from other transmitters in a network or with designated instants in ATSC Time. The control loops generally function to manage the operation of buffers in the path of the data stream so that (potentially variable) delays in the STL path can be compensated automatically, resulting in stable and predictable emission times of signals.

One such time control function involves the establishment of emission of a reference point near the start of each M/H frame in sync with the ticks of ATSC Time. Since ATSC Time runs at a different frequency than the readily-available one-second ticks of the external GPS time reference, a calculation is performed in the Transmission Adapter to determine the instantaneous time offset between the last one-second GPS clock tick and the next occurrence of an AT Tick Alignment Point according to ATSC Time. The value calculated, expressed in Transport Stream Bit Periods, is inserted into the Transmitter Control Packet and sent to the transmitter(s). The value sent enables the transmitter(s) to set buffer delays so that the emission times of the AT Tick Alignment Points occur at the times required by the A/153 Part 2 [5] standard to obtain the necessary precision for the particular application. In addition to the control loops related to the setting of the M/H Frame phasing relative to GPS Time, particularly when the higher precision mode of operation specified by A/153 Part 2 [5] is in use, transmitters also may require an

additional time control loop to stabilize emission times with respect to system delay changes caused by local effects such as temperature variations.

4.4 Single Frequency Networks

Single frequency networks comprise multiple transmitters all sharing a single channel. The transmitters emit identical signals, several of which may be received more-or-less simultaneously by individual receivers. The receivers must treat the multiple received signals as echoes of one another, extracting the data being transmitted despite the possible interference from alternate transmitters within the SFN. The following subsections describe the workings of SFNs and the requirements for receivers and transmitters used in an SFN.

4.4.1 Multiple Transmitters Sharing a Single Channel

In order to allow receivers to treat signals arriving from multiple transmitters as echoes of one another, it is required that the transmitters emit the same signals as one another for the same data inputs. There are two basic techniques for achieving such a condition: Transmitters can repeat signals received off-the-air from other transmitters, thereby guaranteeing that they are transmitting the same signals—although with some delay—or data can be fed to each of the transmitters in parallel, with means provided to ensure that the emitted symbols from all transmitters are the same. It is the latter approach that is facilitated by this standard.

4.4.2 Receiver Requirements

The implementation of SFNs is very much dependent upon the ability of receivers to extract data from received signals having significant levels of echoes at widely spaced time offsets. This capability includes the handling of leading echoes, or “pre-ghosts,” that result from stronger signals arriving at a receiver from transmitters that are farther away or have delayed emission times relative to a nearer transmitter. The time window of echoes—i.e., the “delay spread” (DS)—that can be handled by receivers partly determines how far apart transmitters can be placed in the SFN.

4.4.3 Transmitter Requirements

There are two fundamental requirements for transmitters in a single frequency network: They must emit the same output symbols for the same data inputs, and they must transmit on the same frequency. Any divergence of the output symbols from identity between transmitters will result in receivers not being able to treat the several signals as echoes of one another. Any difference in frequency will cause the apparent echoes in the signal to have the characteristics of a Doppler shift; i.e., for it to seem as though they had been reflected from moving objects. Such Doppler shifts place additional burdens on adaptive equalizers in receivers and are to be avoided.

4.4.4 Forms of Transmission Architecture

Several types of system architectures can be used for digital transmission. The classic scheme is a tall tower with a high power transmitter to cover a large area. Another fundamental approach is the use of a multiplicity of smaller towers with lower power transmitters to cover smaller areas. This is the single frequency network. Although not technically the same as a cellular communications system for a variety of reasons, the areas covered by transmitters in such a system are nonetheless often called “cells.” SFNs can be designed using a few cells covering relatively large areas—the so-called “large cell” scheme—or they can be designed with many cells covering relatively small areas—the “small cell” scheme.

4.5 Distributed Transmission Concept (Transmitter Diversity)

Distributed transmission, or *transmitter diversity*, is unlike any method used in broadcasting in the past. Previously, translators and boosters (on-channel translators) have been used to extend the service areas or fill in gaps in coverage of conventional, high power broadcast stations. Such techniques have been applied to both FM radio and television broadcasting. The power levels of the translators and boosters generally have been low, and the service they provide has been treated as secondary in class.

Distributed transmission (DTx) is intended to use a multiplicity of transmitters to cover a service area without necessarily requiring inclusion of a conventional, high power station, although one or more may be part of the network of transmitters. DTx allows the signal levels throughout a service area to be higher than they would be from a single transmitter, and it also permits better control of interference to neighboring stations. The techniques for achieving these advantages are well understood but beyond the scope of this standard.

The remainder of this subsection will examine some of the system considerations in the use of DTx techniques. This examination will provide necessary background information for the specifications in the later portions of this standard.

4.5.1 Difference from On-Channel Repeaters

On-channel repeaters have been used for some time in the FM radio and the television services to fill in gaps in coverage and occasionally to extend service areas. On-channel repeaters fundamentally receive signals over the air from a main transmitter, from other on-channel repeaters, or from translators and retransmit those signals on the same channel. Because they are essentially amplifiers connected between a receiving and a transmitting antenna, often with processing of various sorts, care must be taken in the design of on-channel repeaters to avoid the signal distortions caused by feedback around the amplifier or, worse, oscillation. As a consequence of the need to avoid feedback, on-channel repeaters are limited in power to a few hundreds or perhaps thousands of watts effective radiated power (ERP). Distributed transmission has no such power limitations and does not suffer from signal degradation due to feedback.

4.5.2 Direct Feed to Each Transmitter

Implicit in distributed transmission is the use of a separate distribution channel to feed the transmitters. The separate distribution channel can be a conventional studio-to-transmitter link (STL) for distributed transmitters, or it can be a different broadcast channel from that on which the transmitter operates in the case of distributed translators. This allows power levels sufficient for large cell designs that would be impossible with on-channel repeaters. The signals fed to the transmitters can be treated as fully modulated and carried on analog distribution media, requiring only conversion to the output channel and amplification, or they can be treated as digital signals requiring data processing and modulation at each transmitter. The use of digital signal distribution results in cleaner emitted signals and may require less bandwidth or signal power on the distribution system.

4.5.3 Multiplicity of Delivery Methods

There is a multiplicity of methods for delivering the signals from the final source multiplexer to the several transmitters in a distributed transmission system. Discounting analog delivery because of the noise added to the delivered signal, digital circuits can include fiber optics using a variety of protocols, satellite data delivery, microwave transmission, and over-the-air broadcast in the case of distributed translators. In each case, it is desirable to keep the data rate to the minimum necessary to deliver the packets to be transmitted. The method described in this

standard maintains the data rate of the transport streams delivered to the transmitters at the same rate as used for the payload in the transmission process, which is the same rate used in conventional 8-VSB transmission (19.39 Mb/s).

4.5.4 Transmission of Identical Symbols

In a single frequency network, it is imperative that the symbols emitted by each of the several transmitters be identical for identical data inputs. The 8-VSB transmission standard embodied in ATSC A/53 makes provision for the synchronization of certain parts of the data processing that takes place before modulation, but it does not relate that synchronization to specific points in the input data stream. Similarly, while the M/H transmission standard embodied in ATSC A/153 makes provision for the synchronization of more elements of the data processing that takes place before modulation than does A/53, it nevertheless still leaves the states of the trellis coding process undefined with respect to specific points in the input data stream. Thus, while the relationships between portions of the data processing systems are specified, the relationships between those elements and the input data will be random, depending upon when the modulator is switched on. Moreover, there are processes within both 8-VSB-based standards that are stochastic and have no fixed relationship at all to the input data stream. Consequently, without further specifications, the requirement for transmission of identical symbols for identical inputs cannot be met by the existing 8-VSB and M/H standards. It is the purpose of this standard to provide the necessary synchronization specifications.

4.5.5 Delay Spread Control

When identical symbols are transmitted from multiple transmitters, receivers will experience those signals as one or more primary signals and echoes dispersed in time. The total time between the earliest arriving signal and the latest arriving signal is called the *delay spread*. When the primary-to-echo (often described in terms of carrier-to-interference – C/I) signal ratio between signals from transmitters in a network falls below a certain value, the delay spread capability in receivers becomes significant in determining whether data can be recovered reliably from the several signals that may be present at a given receiver's location. This factor becomes more significant as the size of cells grows larger. To minimize the delay spread capability required in receivers, control of the time of emission of the signals from transmitters in the network can be used to adjust the delay spread over the service area. Thus, an important element of the synchronization system for distributed transmission is the ability to control the relative emission times of the transmitters in the network.

4.6 Synchronization Requirements

The characteristics of the various data processing blocks of the modulator lead to a set of requirements for synchronizing those functions in a group of separately located transmitters. Requirements exist with respect to frequency synchronization, data frame synchronization, and pre-coder/trellis coder synchronization.

4.6.1 Frequency Synchronization

If the signals arriving at a receiver from multiple transmitters are to be treated as echoes of one another, the frequencies of those transmitters must be close enough to one another that the receiver is not over-burdened with apparent Doppler shift between the signals. This requires that the output frequencies of the transmitters be tightly controlled and maintained with respect to one another.

4.6.2 Data Frame Synchronization

As demonstrated in Section 4.1, the data randomizers, Reed Solomon error correction coders, byte interleavers, and bit interleavers of 8-VSB modulators can be synchronized with one another by properly identifying a starting point for the Data Field, since they all synchronize to it. One more element must be synchronized, however; that is the Data Field Synchronization (DFS) segment that is inserted by the modulator. The DFS carries several PRBS sequences used as training signals for adaptive equalizers in receivers. One of those PRBS sequences alternates in phase from DFS-to-DFS. This creates a Data Frame structure composed of two Data Fields. Because of the integer phase relationship between the Data Frame and its two Data Fields, it is possible to synchronize the Data Frame structure and derive the Data Fields from the Data Frame structure.

4.6.3 Pre-Coding/Trellis Coding Synchronization

As demonstrated in Section 4.1, the pre-coder and trellis coder are stochastic processes not susceptible to initialization by a regularly recurring event in the data stream. Thus, if they are to be synchronized in multiple transmitters, it is necessary to develop state conditions for the pre-coder and trellis coder memories to be applied simultaneously by all transmitters in a network at specific locations in the data stream. This is the method adopted by this standard.

4.7 Transmitter Synchronization Mechanisms

The synchronization requirements outlined in Section 4.6 lead to the reference top-level system configuration shown in Figure 4.6. Whether for a single M/H transmitter or for a conventional 8-VSB or an M/H DTx system, the system comprises three elements: an external time and frequency reference (shown as GPS), a Transmission Adapter (TA) situated at the source end of the distribution (studio-to-transmitter link, STL) subsystem, and a slave synchronization subsystem included in the transmitter(s). The red lines in Figure 4.6 show the paths taken by synchronization signals generated in the TA, and a bar across the top of the figure shows the area of applicability of this standard.

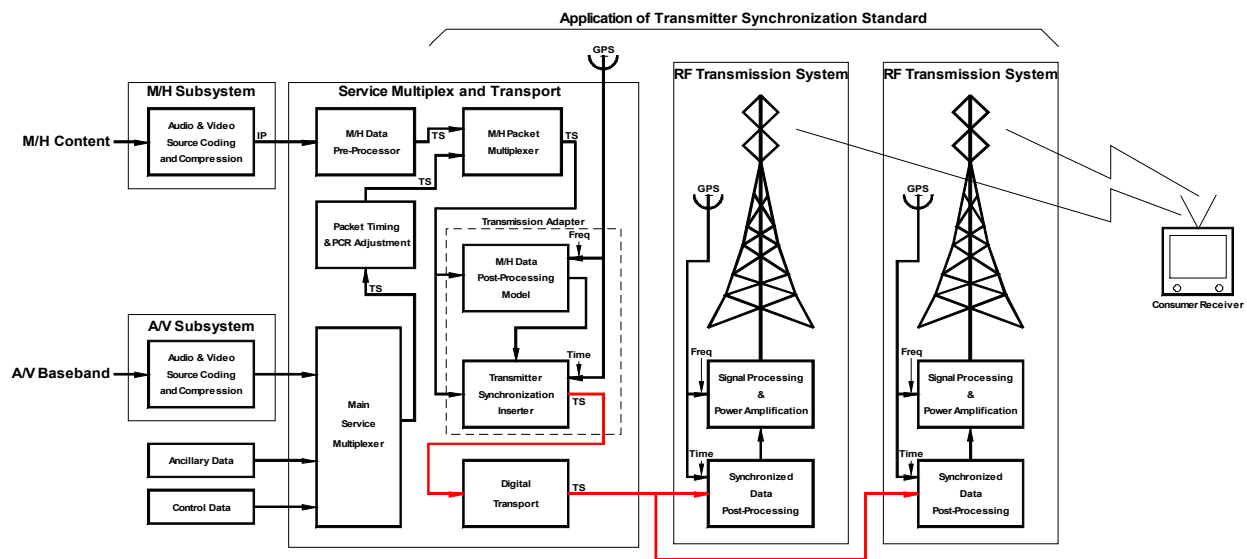

Figure 4.6 Synchronized DTV transmitter block diagram.

4.7.1 Transmission Adapter at Source

The Transmission Adapter (TA) is used to create two types of synchronization information that are multiplexed into the Transport Stream prior to distribution over the STL system. The synchronization information produced by the TA are pointers to the last and next Cadence Sync Points (CSPs), which establishes the phase of the Data Frames relative to the TS packets, and a set of trellis code state values, which are used in Distributed Transmission systems (conventional or M/H) for slaving the pre-coders and trellis coders in the transmitters. These data are carried in a Transmitter Control Packet along with command information specifying the necessary time offset for each transmitter, or they may be carried to single M/H transmitters in unused (dummy data) bytes in MHE packets. In addition, the TA indicates the operating mode to the transmitters and provides information to be transmitted in the Data Field Sync data segment through a Field-Rate Side Channel, which carries information updated regularly at a data field rate. To accomplish these functions, the Transmission Adapter includes a Data Processing Model equivalent to the data processing subsection of an A/53 modulator or an A/153 post-processor and modulator to serve as a master reference to which the slave synchronizers at the transmitters are slaved.

4.7.2 Slave Synchronization of Transmitters

At each transmitter, a Slave Synchronizer is employed to capture the Cadence Sync Points and the trellis code state information, to slave the Data Frame phasing to the Cadence Sync Points, and to slave the pre-coder and trellis encoder to the data in the Transmitter Control Packet (TCP). The Slave Synchronizer extracts mode information from the Field-Rate Side Channel to set the transmitter to the desired mode. It also extracts time offset command information addressed to its associated transmitter and uses it to adjust the emission time of the output symbols (as explained in Section 6.4).

4.7.3 External Time and Frequency Reference

A common time and frequency reference (i.e., GPS) is required at several locations in the system. The Transmission Adapter uses the time component of the external reference to produce the time-offset information to be sent to the Slave Synchronizers to adjust the emission times of their associated transmitters, and the Slave Synchronizers use it to adjust the emission times of their transmitted signals. The TA uses the frequency component to precisely maintain its output Transport Stream data rate to tight tolerances. The transmitters use the frequency component to precisely set their output frequencies to minimize the apparent creation of Doppler shift and the consequent burdening of receiver adaptive equalizers by frequency differences between transmitters, and they use it to reestablish the precise bit rate, and thereby stabilize the timing, of the Transport Stream after its transmission through STLs, which may have some amount of time variation in their delivery of the signal, as, for instance, in satellite relay, some over-the-air receivers, and some microwave systems.

4.8 Distributed Translator Synchronization Mechanisms

When the signal to be transmitted is delivered to a transmitter by another over-the-air broadcast signal, the transmitter is termed a *distributed translator* (DTxR). The synchronization requirements outlined in Section 4.6, when applied to DTxRs, lead to the configuration shown in Figure 4.7. The system comprises four elements: an external time and frequency reference (shown as GPS), a Transmission Adapter (TA) situated at the source end of the distribution (studio-to-transmitter link, STL) subsystem, a transmitter transmitting the signal on one channel, and a slave synchronization subsystem included in each of the translators that transmits the

signal on a second channel. The distributed translators may be cascaded in tiers of translators, with all of the translators in a tier sharing the same output channel. The red lines in Figure 4.7 show the paths taken by synchronization signals generated in the TA.

4.8.1 Transmission Adapter at Source

When distributed translators are used, a somewhat modified configuration is required in the Transmission Adapter (TA) to create for each tier of translators a dedicated Transmitter Control Packet (TCP) that is multiplexed into the Transport Stream prior to distribution over the STL system. At the start of the process, the packet for each tier is loaded with all of the fixed timing and transmitter-specific information that is to be communicated by the TCP to its associated tier of distributed translators. The TCPs thus formed are then passed through a succession of data processing models—one for each tier of distributed translators—in which are calculated and embedded in the related packet the trellis code state information to which the associated tier of distributed translators will be slaved and the error correction coding to protect the packet. The first data processing model in the TA must establish the Cadence Sync Points and pass them along to the successive data processing models. The subsequent data processing models then must lock all of their repetitive processes to the Cadence Sync information. Each of the data processing models establishes its own reference set of trellis code state values to which the trellis coders in the associated tier of distributed translators will be slaved. At the end of the process, information to be transmitted in the Data Field Sync data segment is added to a Field-Rate Side Channel, which carries information updated regularly at a data field rate for control of the first transmitter or tier of transmitters in the network.

Figure 4.7 Synchronized DTV translators block diagram (*see next page*).

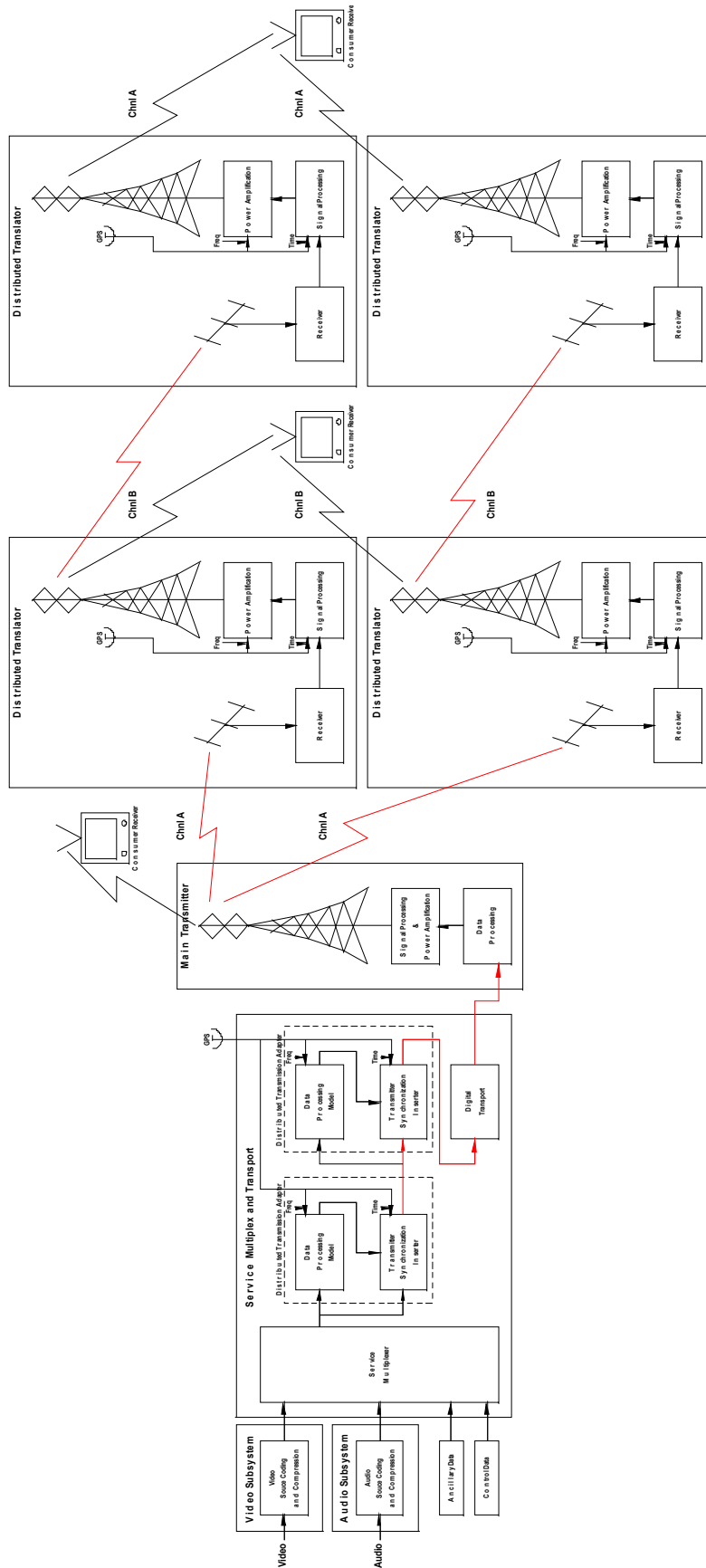

4.8.2 Slave Synchronization of Translators

At each distributed translator, a special receiver is employed to pass along the Data Field Sync data segment information and a Slave Synchronizer is employed to capture the Data Field Sync data and the Transmitter Control Packet (TCP) addressed to the tier in which the translator is situated, to slave the Data Frame phasing to the input signal and TCP information, and to slave the pre-coder and trellis encoder to the TCP data. The Slave Synchronizer extracts mode information from the Data Field Sync data segment from the special receiver to set the translator output to the desired mode. It also extracts time offset command information addressed to its associated translator and uses it to adjust the emission time of the output symbols (as explained in Section 6.4).

4.8.3 External Time and Frequency Reference

The same considerations with respect to use of a common time and frequency reference (i.e., GPS) described for distributed transmitters in Section 4.7.3 apply equally to distributed translators. The same techniques are applied, with the substitution of distributed translators for distributed transmitters where appropriate.

5. SYNCHRONIZATION OF CADENCE SYNC POINTS AND M/H FRAMES

Cadence Sync Points (CSPs) shall be the locations within a Transport Stream at which Data Frame Sync data segments shall be inserted and are locations at which certain repetitive processes in the Transmission Adapter and the Slave Exciter(s) are reset or recycled. Synchronization of Data Frame Sync segment insertion and of data processing functions that are synchronous with the Data Field structure shall be accomplished by calculation of the effective positions of the Cadence Sync Points from the Packet Number information carried in Transmitter Control Packets (TCPs) as described in Section 5.1.² Similarly, the starting points of M/H Frames shall be determined from a combination of the Packet Number and the Packet Frame Number information carried in the TCPs, as described in Section 5.2, or they may be determined for single transmitters from data position information carried in the Dummy Data Bytes Channel, as described in Section 7. To achieve the required emission timing of AT Tick Alignment Points with respect to ATSC Time ticks, it is necessary to release the first CSP in each M/H Frame from the Transmission Adapter at a precise time period prior to the occurrence of an AT tick, as described in Section 5.3.

5.1 Calculation of Cadence Sync Point Positions

Positions of the adjacent Cadence Sync Points in the data stream may be calculated from the Packet Number information included in each Transmitter Control Packet (TCP). As defined in Section 6.2, Packet Number information is carried in the `packet_number` field of the Transmitter

² For signaling insertion points for Data Frame Sync, earlier versions of this standard specified a method that comprised the periodic replacement of the MPEG-2 Transport Stream sync word with a bit-wise inverted version of the sync word. That is, a sync word value of 0xB8 was inserted in place of the standard value of 0x47 every 624 packets, without regard to the content of the packets,

Although no longer supported in this version of the standard, some applications may benefit from use of the sync word inversion technique during system set up or troubleshooting, whereas certain STL systems are known to fail when presented with inverted MPEG-2 packet sync words.

Control Packet (TCP). The Packet Number information designates the number of the packet in which the TCP is carried. Counting begins with the value 0 assigned to the packet the start of which is the Cadence Sync Point defined in Section 5. Thus, the last previous occurrence of the CSP was prior to the header of the packet that appeared in the data stream the number of packets indicated in `packet_number` prior to the packet carrying the TCP. Similarly, the next CSP will occur prior to the header of the packet that will be $(624 - \text{packet_number})$ packets following the packet carrying the TCP. Note that it is the next CSP for which the Synchronization Time Stamp (STS), defined in Section 6.2, gives the time of release from the TA.

5.2 Calculation of M/H Frame and Sub-Structure Boundary Points

The starting and ending points of M/H Frame, Sub-Frame, and Slot structures all are offset ahead of Cadence Sync Points by 37 MPEG TS packets. That is, they occur in the Transport Stream 37 MPEG packets prior to the occurrence of a CSP. To permit determining the locations of the boundaries of the several framing structures surrounding any TCP, each TCP carries information on the frame number within which that TCP is located. The value of the `packet_frame_number` field, as defined in Section 6.2, when combined with the Packet Number information, permits calculating the positions of the preceding and following boundaries of the M/H Frame and its sub-structures.

Similar to the Cadence Sync Point (VSB Frame boundary) positions, the locations of the M/H Frame boundaries can be calculated in terms of the number of packets preceding and following the TCP at which they occurred or will occur. The Packet Frame Number designates the number of VSB Frame periods following the M/H Frame boundary at which the TCP is located. Counting of VSB Frame periods begins with the value 0 assigned to the VSB Frame period that begins immediately following the M/H Frame boundary, i.e., that starts in Slot 0 of the M/H Frame. From any location of the TCP, then, the preceding M/H Frame boundary was prior to the header of the packet that appeared in the data stream

$$(\text{packet_frame_number} * 624 + \text{packet_number} + 37) \bmod 12480 \quad (1)$$

packets prior to the packet carrying the TCP. Similarly, the next M/H Frame boundary will occur prior to the header of the packet that will be

$$12480 - ((\text{packet_frame_number} * 624 + \text{packet_number} + 37) \bmod 12480) \quad (2)$$

packets following the packet carrying the TCP.

5.3 Calculation of CSP Back-Timing for AT Tick Alignment

To achieve correctly-timed emission, it is necessary to release the first CSP in each M/H Frame from the Transmission Adapter prior to the occurrence of the corresponding AT Tick by an amount of time equal to the total transit time through the complete system from Transmission Adapter output to antenna. This relationship applies both to single transmitters and to multiple transmitters in an SFN. Since all STLs do not have the same time delays and do not necessarily maintain constant time delays, a fixed delay value is applied to the time from TA output to emission and is set as a system parameter, known as Maximum Delay and defined in Section 6.4.2 below. Transmitter exciters use the instructions sent to them by the Transmission Adapter, including the Maximum Delay value, to determine the time at which to emit the data to be transmitted. The Transmission Adapter consequently must release the first CSP in each M/H

Frame into the STL ahead of (back-timed from) the corresponding AT Tick time by the value of Maximum Delay.

Since the information available to Transmission Adapters is required to be derived from GPS and includes the GPS Seconds value and the instants of GPS 1-second ticks, that information shall be used to compute the time of the next AT Tick from which to back-time the CSP release from the TA. Given any value of GPS Seconds, the time (in GPS seconds) of the next AT Tick is the value found from:³

$$\text{GPS}_{\text{secs.AT.tick}} := \frac{4654936}{4809375} \cdot \text{ceil} \left(\frac{4809375}{4654936} \cdot \text{GPS}_{\text{secs}} \right) \quad (3)$$

Where GPS_{secs} is the time in GPS Seconds, GPS_{secs} , AT.tick is the time in GPS seconds at which the next AT Tick will occur, and $\text{ceil}(x)$ is the smallest integer not less than x .

Note that the time of an AT Tick can be simultaneous with the time of a GPS 1-second tick and will be so every 4,654,936 seconds (approximately every 54 days). Given the time of the next AT Tick (i.e., $\text{GPS}_{\text{secs.AT.tick}}$), as derived using formula (3) above, the Transmission Adapter shall release the first CSP in each M/H Frame at time:

$$\text{CSP}_{\text{release}} = \text{GPS}_{\text{secs.AT.tick}} - \text{MD} * 223795 / 433998 \quad (4)$$

Where $\text{CSP}_{\text{release}}$ is the time,⁴ in GPS seconds, at which the CSP is released into the STL, and MD (as defined in Section 6.4.2) is the length of time represented by the Maximum Delay parameter, expressed in Transport Stream Bit Periods.

6. TRANSMITTER CONTROL PACKET STRUCTURE

Synchronization of the pre-coder and trellis coder functions of the data processing blocks, which are not synchronous with the Data Field or any other defined structure, as well as the synchronization of the data framing structures, shall be accomplished by the sending of Transmitter Control Packets (TCPs), as described in this section, from the Transmission Adapter (TA) to each transmitter. TCPs are a specific form of Operations and Maintenance Packet (OMP), as defined in Section 6.1.

A TCP passes through three stages of formatting as it moves from the final service multiplexer or remultiplexer (which may be within the TA), through the TA to the transmitters, and then through the transmitters. In each stage, the TCP has a different set of semantics. It is formatted with a fixed set of payload values when it is first formed and/or scheduled in the service multiplexer, packet multiplexer, transmission adapter input process, or similar upstream function. The formatting of the payload upon formation in the upstream operation is described in Section 9.2.2, Transmitter Control Packet Pre-Processing Payload. The initial payload is replaced in two stages in the TA as described in Section 9.4, Transmitter Control Packet Payload Substitution, to form a packet having the semantics described in this Section 6 for distribution to

³ Note that GPS seconds and AT Ticks both are expressed as 32-bit values and consequently will roll over at separate times in the future, creating discontinuities in the operation of formula (3).

⁴ Note that rounding and/or truncation errors will occur in the computation of $\text{CSP}_{\text{release}}$ if insufficient precision is employed in computing its value. For accuracy of ± 1 transport stream bit period, a minimum of 57 bits of precision is required to cover the full range of values of GPS_{secs} .

the transmitter(s). At the transmitter(s), part of the TCP payload is restored to its initial values, as described in Section 10.3, Transmitter Control Packet Payload Replacement.

6.1 Operations and Maintenance Packet Structure

An Operations and Maintenance Packet (OMP) is private data from the perspective of MPEG-2 Systems [4]. The OMP structure can be used to support a variety of operations and maintenance functions in a system. It can have various data structures, depending upon the purposes it serves in specific applications. The first such packet structure defined is the Transmitter Control Packet (TCP).⁵

6.1.1 Transport Header Constraints

The header of an Operations and Maintenance Packet shall conform to the structure specified for MPEG-2 Transport Stream packets in ISO/IEC 13818-1 Systems [3], which defines a 4-byte header and a 184 byte payload. The header and payload contents are as defined in the following sections.

6.1.1.1 PID Assignment and OM Type

The header contains a 13-bit Packet Identifier (PID) field. One value is defined to identify an Operations and Maintenance packet. The assigned PID value shall be 0x1FFA. This standard defines configuration of the OMP to form Transmitter Control Packets.

6.1.1.2 Constraints on OMP transport_packet Header Field Values

The transport_error_indicator field shall be set to zero except when Section 8.2 Field-Rate Side Channel Format applies. The transport_scrambling_control field shall be set to zero. The transport_priority and payload_unit_start_indicator fields shall be set to one. The adaptation_field_control field shall be set to '01' (meaning "no adaptation_field, payload only"). The continuity_counter shall increment by one for each occurrence of the OMP, cycling from '0000' to '1111', then beginning again at '0000'.

6.1.2 Operations and Maintenance Packet Payload Structure

In an OMP, the first byte of the 184-byte payload indicates the type of data structure contained in the remainder of the payload. The syntax of the OMP 184 byte payload shall be as shown in Table 6.1, and the semantics shall be as described in the paragraphs that immediately follow it.

Table 6.1 Operations and Maintenance Packet (OMP) Organization

Syntax	No. of Bits	Format
OM_packet () {		
OM_type	8	bslbf
OM_payload	8*183	bslbf
}		

⁵ Named the Distributed Transmission Packet (DTxP) in earlier versions of this standard.

OM_type – This 8-bit field shall be set to a value between 0x00 and 0x1F to indicate a Transmitter Control Packet. Multiple values of OM_type may be used within a network to expand the number of transmitters that can be controlled beyond the number that can be addressed using a single OM_type value. When used in a network of cascaded transmitters, the value of OM_type should indicate the tier of the cascaded network to which the packet is addressed, as described in Section 9.2.4 Transmitter Control Packet Formation for Distributed Translators. The value of OM_type should be assigned to tiers in sequence proceeding away from the source end of the network, starting with 00 for the tier closest to the source and incrementing by one for each successive tier in the cascade. All other values of OM_type are reserved by ATSC and may be used in other standards. The ATSC Code Points Registry will contain a reference to any such definition.

OM_payload – This field comprises the 183 bytes in an OMP following the standard MPEG-2 Transport Stream header and the OM_type field. For OM_type values between 0x00 and 0x1F, this field shall be the Transmitter_Control_Packet () as defined in Table 6.2.

6.2 Transmitter Control Packets

Transmitter Control Packets shall constitute a particular form of Operations and Maintenance Packet as identified by their OM_type values. Transmitter Control Packets shall comprise a header, trellis coder state data, transmitter timing control data, and Reed-Solomon error correction coding, as well as several additional items of information. The structure of a Transmitter Control Packet shall be as shown in Table 6.2, which expresses the information in the pseudo-C language format used by the MPEG-2 standards, and the data that it carries shall have the meanings defined in the text following the table.

The five right-most columns in Table 6.2 indicate utilization of the various semantic elements of the TCP in different transmission system operating modes. Indicators within the columns show whether specific semantic elements are required (“+”) for a given mode or are optional (“o”) for the mode. When there is no symbol for a particular element in a column for a mode, that element is inapplicable to the mode.

Five operating modes are represented by the five columns. From left to right, they are for an SFN operating in conventional 8-VSB (A/53) format, with no M/H capability; a single transmitter operating in M/H (A/153) format; an SFN operating in M/H (A/153) format; a single transmitter having M/H (A/153) capability but operating in standard 8-VSB (A/53) format; and an SFN having transmitters capable of operating in M/H (A/153) format but actually operating in standard 8-VSB (A/53) format. The latter two modes are provided so that synchronization can be maintained between Transmission Adapters, slave transmitters, and ATSC Time, even when the transmission system is not currently operating in M/H (A/153) format. They enable seamless transitions between the two forms of operation (A/53 and A/153).

When semantic elements are unused in a particular mode of operation or because the address of the transmitter to which they otherwise would pertain is unused within the network, all the bits within those elements shall be filled with a value of '1'. Similarly, all the bits in the payload of a precursor packet are set to a value of '1', as described in Section 9.2 Transmitter Control Packet Formation, and values used across the STL that must be restored prior to transmission are reset to a value of '1', as described in Section 10.3 Transmitter Control Packet Payload Replacement.

Table 6.2 Transmitter Control Packet (TCP) Organization

Syntax	No. of Bits	Format	SFN 8-VSB	Single M/H	SFN M/H	Single Non-M/H	SFN Non-M/H
Transmitter_Control_Packet (TCP) () {							
Signaling_Data {							
packet_frame_number	5	uimsbf		+	+	+	+
mode	1	bslbf		+	+	+	+
reserved	2	'11'					
}							
for (i=0; i<12; i++) {							
trellis_code_state	8	riuimsbfwp	+	o	+	o	+
}							
synchronization_time_stamp_base	24	uimsbf	+	+	+	+	+
maximum_delay_base	24	uimsbf	+	+	+	+	+
network_identifier_pattern	12	uimsbf	+	+	+	+	+
synchronization_time_stamp_extension	1	bslbf (MSB)	+	+	+	+	+
maximum_delay_extension	1	uimsbf (MSB)	+	+	+	+	+
packet_number	10	uimsbf	+	+	+	+	+
adjusted_gps_seconds_count	32	uimsbf		+	+	+	+
tx_group_number	8	uimsbf	+	o	+	o	+
for (i=0; i<16; i++) {							
tx_address	12	uimsbf	+	o	+	o	+
tx_identifier_level	3	uimsbf	+	o	+	o	+
tx_data_inhibit	1	bslbf	+	o	+	o	+
tx_time_offset	16	tcimsbf	+	o	+	o	+
tx_power	12	uipfmsbf	o	o	o	o	o
reserved	4	'1111'					
}							
AT_frame_number	32	uimsbf		+	+	+	+
atsc_time_displacement	25			+	+	+	+
reserved	263	for (i=0; i<263; i++) '1'	+	+	+	+	+
TCP_ECC	160	uimsbf	+	+	+	+	+
}							

packet_frame_number – A 5-bit unsigned integer field that counts the VSB Frames within an M/H Frame. It shall increment from 0 through 19 and recycle. It shall increment its value 37 packets following an M/H Frame boundary (corresponding to the beginning of a VSB Frame, i.e., at a CSP) and every 624 packets thereafter (upon the occurrence of each CSP) and shall have the value 0 starting with the first CSP to occur following the beginning of each M/H Frame. Note that, as a consequence of this process, its value increments at the beginning of

the 38th packet (TS packet #37 – see Figure 4.3) within the first Slot and every fourth Slot thereafter within an M/H Frame.⁶

mode – A 1-bit field that indicates the presence of M/H data in the stream. It shall have a value of 0 when M/H data are present and a value of 1 otherwise. Its value shall continue to indicate the presence of M/H data during intervals when no M/H data are carried in the stream but will be carried within a period of 8 M/H Frames following the current M/H Frame. This value shall be used to control signaling of the presence of M/H data in the emission.

trellis_code_state – An 8-bit field carrying two copies of the three bits of the state of a precoder and trellis encoder pair plus parity, with one copy bit-inverted from the other, as further defined in Section 6.3 Trellis Code State Data.

synchronization_time_stamp_base – A field carrying the 24 least significant bits of a 25-bit unsigned integer Synchronization Time Stamp value that indicates the elapsed time, measured in TS Bit Periods, between a GPS 1-second tick and the release from the TA of the next CSP following the TCP.

maximum_delay_base – A field carrying the 24 least significant bits of a 25-bit unsigned integer Maximum Delay value that indicates the time delay setting in the system, measured in TS Bit Periods, between the output time of a datum from the TA and the reference time of emission of the corresponding symbol from the transmitter(s).

network_identifier_pattern – A 12-bit unsigned integer field, uniquely representing the network in which the transmitter is located, that provides the seed value for 12 of the 24 bits used to set the symbol sequence of a unique code assigned to each transmitter. All transmitters within a network shall use the same 12-bit pattern, which shall be unique within interference range of the network and the value of which shall match the 12 least significant bits of the Transport Stream Identifier (TSID) value used by that network.⁷ A single transmitter shall be treated as its own network.

synchronization_time_stamp_extension – A field carrying the MSB of a 25-bit unsigned integer Synchronization Time Stamp value that indicates the elapsed time, measured in TS Bit Periods, between a GPS 1-second tick and the release from the TA of the next CSP following the TCP.

maximum_delay_extension – A field carrying the MSB of a 25-bit unsigned integer Maximum Delay value that indicates the time delay setting in the system, measured in TS Bit Periods, between the output time of a datum from the TA and the reference time of emission of the corresponding symbol from the transmitter(s).

packet_number – A 10-bit unsigned integer field that indicates the number of MPEG-2 Transport Stream packets that have occurred in the stream since the last CSP, to and including the TCP. Packets are numbered from 0 to 623. Packet 0 begins at the CSP.

⁶ A consequence of the alignment of the Cadence Sync Points and the M/H Frame boundaries, as described herein, is that the value of `packet_frame_number` was 19 and the value of `packet_number` was 587 at the start of the first M/H Frame, which preceded the ATSC Epoch by the period of 37 packets.

⁷ In the case of a conflict between the requirements for uniqueness within interference range of a network and for use of the least significant bits of the TSID value, the requirement for uniqueness shall take priority.

- adjusted_gps_seconds_count** — A 32-bit unsigned integer field carrying the value of the GPS seconds count immediately prior to the release of the TCP from the TA, or that value incremented by one. When the sum of the values in the `synchronization_time_stamp` and `maximum_delay` fields is less than or equal to 19,392,658, the non-incremented value shall be carried in the field. When the sum of the values in the `synchronization_time_stamp` and `maximum_delay` fields is greater than 19,392,658, the incremented GPS seconds count value shall be carried in the field.
- tx_group_number** — An 8-bit unsigned integer field that carries the first 8 bits of the 12-bit addresses of the group of transmitters to which information is individually addressed in the packet instance. This field provides redundant information to improve reliability of the addressing of data to the transmitters.
- tx_address** — A 12-bit unsigned integer field that carries the address of the transmitter to which the following fields are relevant and which shall be used to seed a portion of the RF watermark code sequence generator. `tx_address` shall be unique for each transmitter within the scope of each `OM_type` value within a network.
- tx_identifier_level** — A 3-bit unsigned integer field that indicates to which of 8 levels (including off) the RF watermark signal of each transmitter shall be set, as defined in Section 6.7.5 Transmitter Identifier Levels.
- tx_data_inhibit** — A 1-bit field that indicates when the `tx_data` information should not be encoded into the RF watermark signal. A value of 0 shall indicate that `tx_data` encoding into the RF watermark signal is to be inhibited.
- tx_time_offset** — A 16-bit signed integer field that indicates the time offset, measured in TS Bit Period increments, between the reference emission time, determined using Synchronization Time Stamp plus Maximum Delay, and the time of emission of the individual transmitter to which it is addressed.
- tx_power** — A 12-bit unsigned integer plus fraction that indicates the power level to which the transmitter to which it is addressed should be set. The most significant 8 bits indicate the power in integer dB relative to 0 dBm, and the least significant 4 bits indicate the power in fractions of a dB. When set to zero, `tx_power` shall indicate that the transmitter to which the value is addressed shall be muted.
- AT_frame_number** — A 32-bit unsigned integer field that indicates the count of M/H frames since the epoch for the M/H frame within which the current TCP resides, as it will be emitted from the transmitter(s). Note: that the first CSP of each M/H Frame is released into the STL prior to occurrence of the corresponding AT Tick at the time defined as $CSP_{Release}$ in Equation (4).
- atsc_time_displacement** — A 25 bit unsigned integer field that carries the value of the time difference between the last GPS 1-second tick preceding the first bit of the MPEG-2 packet sync byte in the header of the TCP and the next ATSC Time (AT) tick following the GPS 1-second tick,⁸ expressed in TS Bit Periods rounded to the nearest integer value. The value of `atsc_time_displacement` shall be calculated according to the following mathematical relationship, applied to the value of GPS seconds carried in the `adjusted_gps_seconds_count` field:

⁸ Note that the GPS 1-second tick referenced always will precede or occur at the same time as the first bit in the MPEG-2 packet sync byte in the header of the TCP; however, the next AT Tick following that GPS tick may precede, occur at the same time as, or follow the occurrence of the first bit of the TCP packet sync byte.

$$\text{atsc_time_displacement} = 18,769,920 * (1 - \text{mod}(\text{adjusted_gps_seconds} * 4809375/4654936, 1)) \quad (5)$$

TCP_ECC – A 160-bit unsigned integer field that carries 20 bytes of Reed Solomon error correcting code used to protect the remaining 164 payload bytes of the packet, as described in Section 6.8.1.

6.3 Trellis Code State Data

Trellis Code State Data shall comprise a total of 36 bits, drawn in 3-bit groups from each of the 12 independent pre-coder and trellis encoder combinations making up the overall pre-coder and trellis encoder system inside the symbol interleaver. The extraction of the bits from the data processing model at the Transmission Adapter shall be carried out according to the methods illustrated in Figure 6.1, which shows the trellis coder synchronization source, and Figure 6.2, which shows the trellis code interleaver synchronization source. (Note that the designations of signals in Figure 6.1 match those of A/53 Part 2 [1], Figure 6.8.)

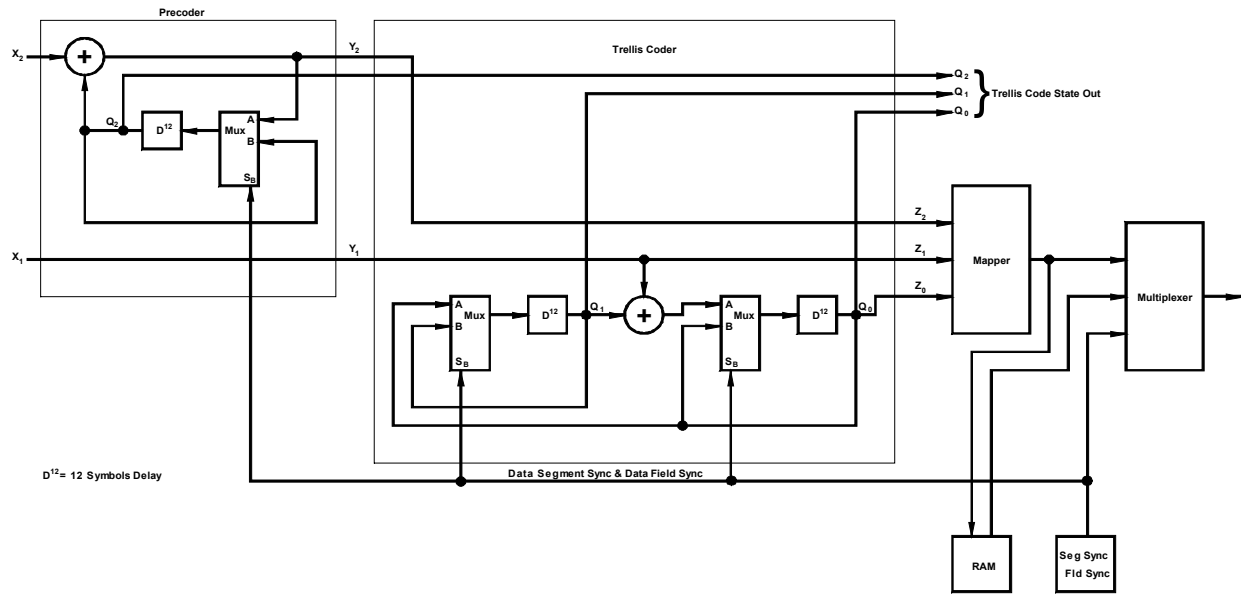

Figure 6.1 Trellis coder synchronization source.

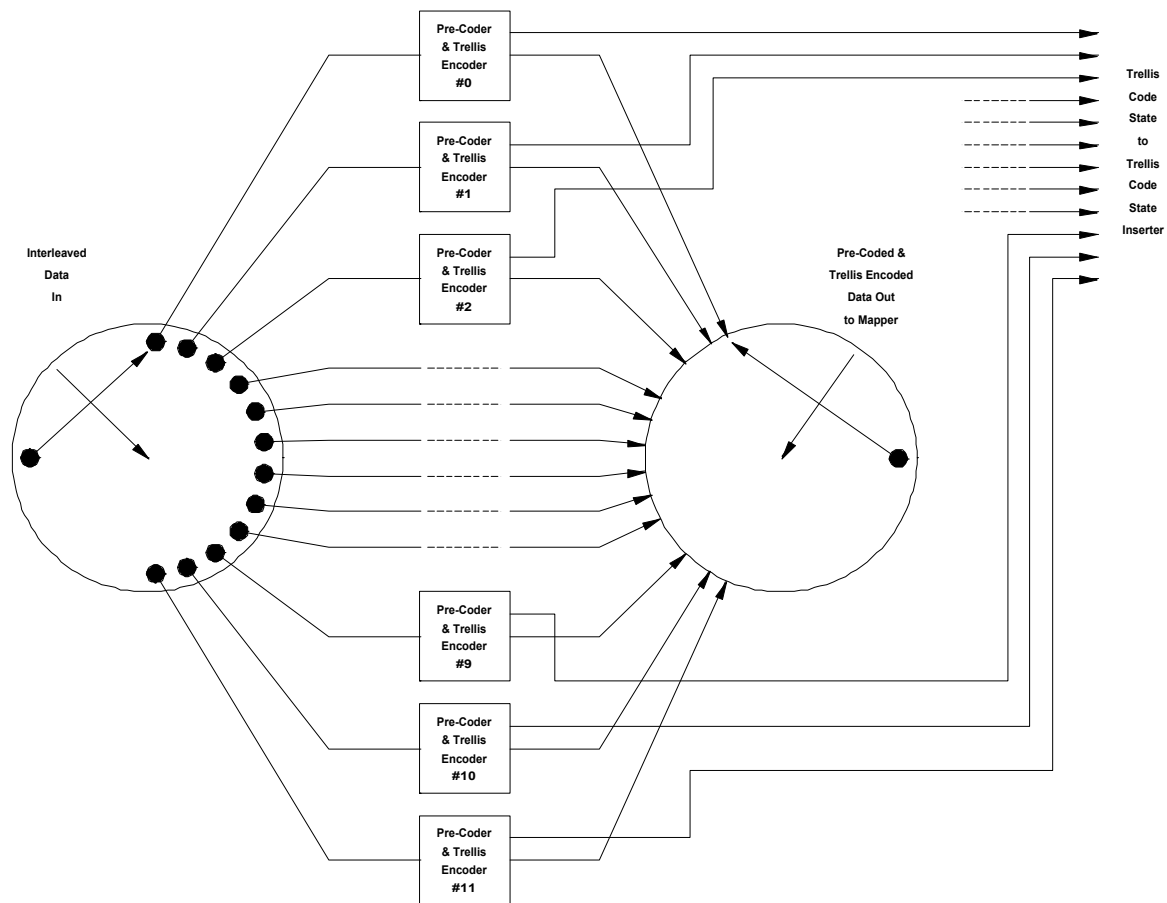

Figure 6.2 Trellis code interleaver synchronization source.

6.3.1 State of Trellis at Next Data Field Start

The Trellis Coder State Data shall represent the states of the 36 storage devices in the pre-coder and trellis coder subsystem of the data processing model of the Transmission Adapter, as they will be immediately following Data Field Sync at the start of the next Data Field following the appearance of the TCP in the MPEG-2 Transport Stream.

6.3.2 Format

The Trellis Coder State Data shall be packaged into the twelve payload bytes (the `trellis_code_state` fields) following the `OM_type` and `Signaling_Data ()` fields, each byte carrying the three bits of state data derived from the corresponding one of the twelve pre-coder and trellis coder combinations conceptually used in the system; i.e., the first byte of the twelve shall carry the data from pre-coder and trellis coder 0, the second byte of the twelve shall carry the data from pre-coder and trellis coder 1, and so on. The twelfth byte of the twelve shall carry the data from pre-coder and trellis coder 11.

A parity bit (even) shall be added to the three data bits from each combination of pre-coder and trellis coder, and the resulting four bits also shall be carried inverted bit-by-bit in the same byte for redundancy. Specifically, the three non-inverted bits of trellis coder state data plus

parity shall be carried in the most significant bits (bits 4–7) of the byte corresponding to the particular pre-coder and trellis coder combination. The bits shall be ordered so that Q_0 , Q_1 , and Q_2 of Figure 6.1 are placed in bits 4, 5, and 6, respectively, of the corresponding byte. The msb (bit 7) shall carry the even parity bit for the next three lower bits. The four lsb's of the byte (bits 0–3) shall carry the inverses of the corresponding bits, four bits higher in rank in the same byte; i.e.,

$$b0 = \overline{b4}, b1 = \overline{b5}, b2 = \overline{b6}, \text{ and } b3 = \overline{b7}$$

The structure of a Trellis Coder State byte is shown in Figure 6.3.

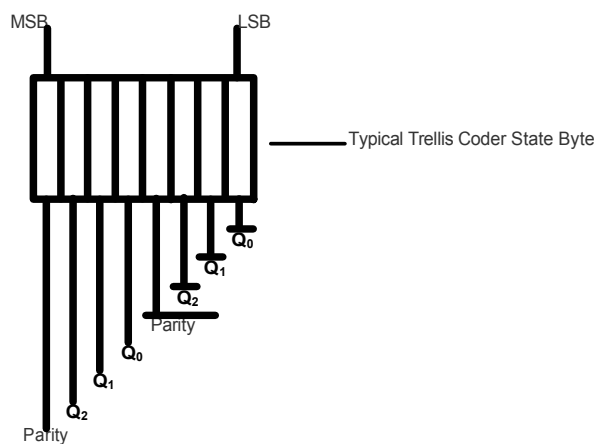

Figure 6.3 Trellis coder state byte layout.

6.4 Transmitter Timing Control Data

In order to enable multiple transmitters in a single-frequency network to be set to transmit their signals in specific time relationships to one another, it is necessary to provide a time reference to all transmitters and to offset some or all of them in time by amounts determined by the network design. Similarly, to enable single transmitters transmitting M/H signals to achieve the emission timing accuracy required with respect to ATSC Time ticks, it is necessary to provide equivalent time reference information to control emission timing. While such timing adjustments could be made on a fixed basis, in far-flung networks, it can be quite helpful to have means to adjust the timing of transmissions remotely. Moreover, the delays in STL paths of all types are known to vary, and the variations must be compensated to obtain the required emission timing accuracy. Consequently, provision is made in the Transmitter Control Packet to carry timing control information to a single transmitter or individually to each of the transmitters in a network.

The transmitter timing control function operates by sending two time reference values to the singular transmitter or to all transmitters in a network and a third time value individually to each network transmitter. The two time reference values sent to all transmitters are a Synchronization Time Stamp (STS) and a Maximum Delay (MD) value. The third time value is an Offset Delay (OD) that is specific to each transmitter in a network. The Emission time for each transmitter is the combination of STS, MD, and OD. The timing is dependent upon a common time reference (e.g., GPS time, as required herein) being available to each of the nodes in the network,

including the Transmission Adapter and each of the transmitters. The relationships between the various elements of the transmitter timing control functionality are shown in Figures 6.4a and 6.4b. Figure 6.4a shows these elements for the base case, which is the reference and applies to a single transmitter (i.e., where no timing offset is applied). Figure 6.4b shows the elements of transmitter timing control with respect to the multiple transmitters in a network when timing offset is applied.

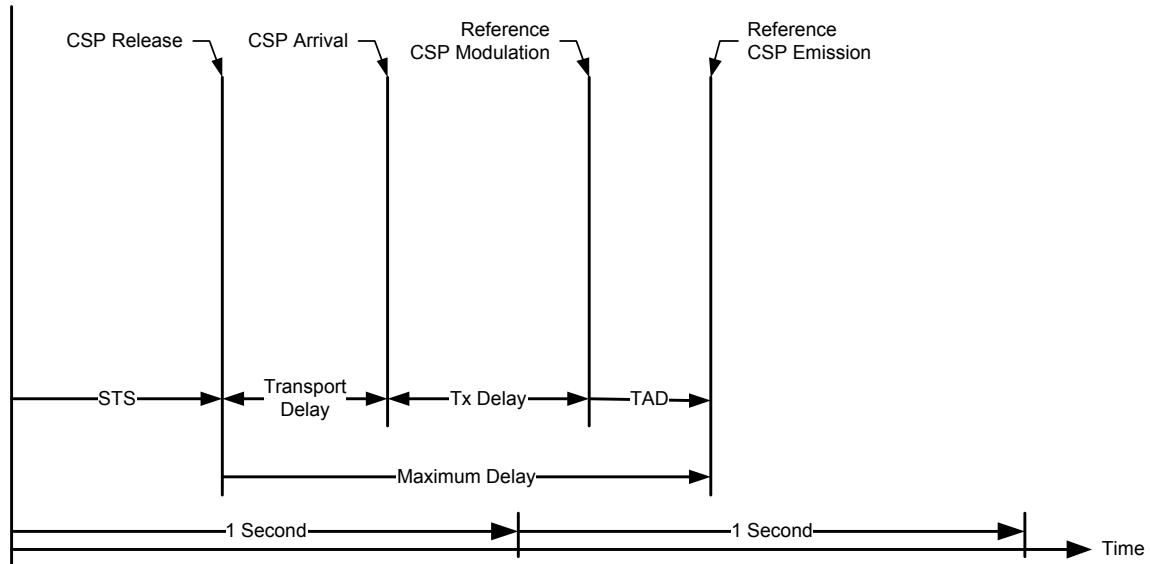

Figure 6.4a Transmitter timing control relationships—reference and single transmitter case.

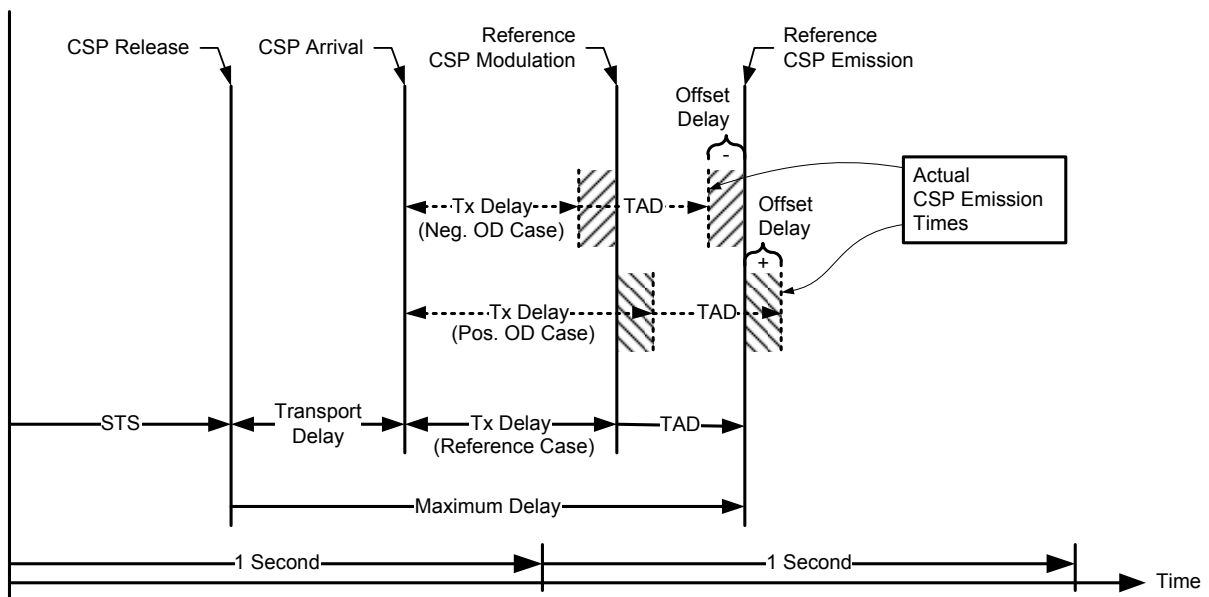

Figure 6.4b Transmitter timing control relationships—SFN case.

6.4.1 Synchronization Time Stamp (STS)

The Synchronization Time Stamp (STS) information shall be carried in the Synchronization Time Stamp fields and shall be the number of TS bit periods between the leading edge of the last 1-second GPS tick and the occurrence of the next CSP following the TCP in the MPEG-2 Transport Stream at the output of the Transmission Adapter, rounded to the nearest value. (See Section 9.)

6.4.2 Maximum Delay (MD)

The Maximum Delay (MD) information shall be carried in the Maximum Delay fields and shall be a value that is set as a system parameter so as to assure that the output times of all transmitters in the network will be delayed sufficiently to account for the longest delay in the distribution path to any transmitter plus the delay of the transmitter itself and its antenna system. It shall be measured in TS bit periods and shall take a value between a lower and an upper bound such that, when MD is added to the Offset Delay (OD) plus the delay time of the transmitter and antenna system, the total neither falls below 0x000001 nor exceeds 0x127E891 (i.e., the total falls within the range between one count and one count less than 1 second). Nominal lower and upper bound values of MD of 0x00F8FC and 0x126EF96, respectively, can be considered usable without further calculations. In unusual situations in which it is necessary to more closely approach the limiting values, care should be taken to calculate the total of all delays so that the limits of one count more than zero and of one count less than one second are not exceeded under any circumstances of system operation. The values given are sufficient to allow for distribution systems using satellite transponders to reach transmitters in a network.

6.4.3 Transmitter and Antenna Delay (TAD)

The Transmitter and Antenna Delay (TAD) value relates to individual transmitters and shall include the total delay from the input to the Modified Data Randomizer (see Figure 10.1), at which point the transmitter output timing shall be measured and controlled, to the output of the antenna. TAD shall equal the time from the entry of a Cadence Sync Point into the Data Randomizer to the appearance at the antenna output of the start of the symbol immediately preceding the leading edge (zero crossing of the +5 to -5 transition) of the segment sync of the corresponding Data Frame Sync data segment (i.e., the segment sync that occurs at the start of the corresponding Data Frame Sync data segment).⁹ TAD shall be compensated by each transmitter through release of CSPs into the modulation process prior to the times at which they are required to be emitted from the antenna by a time interval equal to TAD. TAD compensation shall be performed through a calculation subtracting TAD from the OD-adjusted emission times

⁹ Beyond the Data Randomizer, the data processing path does not have a constant delay. Insertion of field and frame sync data segments, insertion of error-correction data, and the process of interleaving cause the instantaneous time delay through the data processing blocks to vary as a function of position in a data frame. The TAD value establishes a delay reference for a particular point in a data frame—the Cadence Sync Point and the corresponding start of the data frame sync data segment—which is used to time-align all transmitters at their outputs, even though they may have different data and signal processing delays.

of transmitters in an SFN (as in Figure 6.4b) or from the reference emission time of a single transmitter (as in Figure 6.4a), using a value of TAD determined for each specific transmitter.¹⁰

6.4.4 Offset Delay (OD)

The Offset Delay (OD) information shall be carried in the `tx_time_offset` fields and shall be a value that is set as a parameter for each transmitter so as to allow adjustment of the emission timing of transmitters with respect to one another. It shall be measured in TS bit periods and shall take a value between $-32,768$ and $32,767$ (i.e., from -1.68971 ms to 1.68966 ms). The OD-adjusted emission time of each transmitter shall be compensated for the Transmitter and Antenna Delay (TAD) of that transmitter. The total spread between emission times of transmitters in a network thus can be up to 3.37937 ms (possibly limited by any differences in transmitter and antenna system delays).

6.4.5 CSP Modulation and Reference Emission Times

The CSP Modulation time for each transmitter shall be the time of arrival at the input of the Modified Data Randomizer of the Cadence Sync Point.¹¹ The Reference Emission time shall occur at a time equal to the sum of the Synchronization Time Stamp value plus the Maximum Delay value (STS + MD) carried in the TCP. Each single transmitter shall use that Reference Emission time, and each transmitter in a network shall use that Reference Emission time plus the Offset Delay (OD) for that transmitter, minus that transmitter's TAD value, to determine its required CSP Modulation time value. A transmitter's emission time shall equal its CSP Modulation time plus its TAD value. When the calculated Reference Emission time exceeds 1 second ($0x127E892$), 1 second shall be subtracted from the Reference Emission time value to find the Reference Emission time relative to the leading edge of the most recent 1-second tick of the GPS time reference.

6.4.6 Determining Transmitter Delay

A transmitter may determine the delay required (Tx Delay in Figures 6.4a and 6.4b) between its reception from the transport system of any given Cadence Sync Point and input of that CSP to the Modified Data Randomizer by measuring, in TS bit periods, the time from the leading edge of the last 1-second tick of the GPS time reference to the time at which it receives the CSP (CSP Arrival). The emission time for that transmitter minus the time of CSP arrival minus the TAD value yields the delay time (Tx Delay) required, in TS bit periods, from the point at which CSP arrival is measured to the input of the Modified Data Randomizer.

¹⁰ Either a fixed value determined individually for each transmission facility may be applied as a TAD setup parameter, or a closed-loop compensation system may be applied to adjust the value of TAD to obtain higher precision in emission timing, e.g., to compensate for time delay variations of various RF system components with factors such as ambient temperature.

¹¹ Although the Modified Data Randomizer does not affect the sync byte of the packet that begins at the CSP (which sync byte eventually is replaced by segment sync), the Modified Data Randomizer input is used as the reference point for determining TAD. Not only is this a suitable conceptual reference, it also is a point where delay easily may be measured physically by system implementers with a logic analyzer or an oscilloscope. The delay from the start of MPEG sync input at this point to emergence of the start of the corresponding segment sync from the modulator is the delay value for the modulator block. Addition of this value to the delay in the RF circuits, mask filter, transmission line, and other system elements yields the TAD value.

6.5 Transmitter Identification and Signaling

In a distributed transmission network, identifying each of the transmitters when it is received over the air can be a difficult proposition. This difficulty occurs because the signal from each of the transmitters is intentionally made to be identical to all the others so that adaptive equalizers in receivers can treat them as echoes of one another. Yet it can be very useful to determine which transmitters are being received at a particular location and, indeed, what their contributions are to the aggregate received signal in order to permit optimization of the network adjustments. It also can be very useful to identify interfering signals from another DTx network or a single digital transmitter. So as to allow identification of individual transmitters, provision is made to assign specific, identifiable codes to particular transmitters, the assignment of which is communicated through the TCP. Moreover, a similar code to identify the network also is communicated through the TCP. The codes are combined and used to generate a symbol sequence that is modulated synchronously with the host 8-VSB symbols in such a way that ordinary receivers cannot detect their presence but special monitoring and measuring instruments can. Such buried identification signals also are called “RF watermarks.”

6.5.1 Transmitter and Network Identification Signaling

Identification of individual transmitters is signaled by causing them to transmit direct sequence buried spread spectrum (BSS) RF watermark signals carrying a unique Kasami code sequence for each transmitter in each network (or for single transmitters, which are treated as their own networks). The symbols of the RF watermark signals are transmitted synchronously with the symbols of the host 8-VSB transmissions, as described in Section 13. The transmitter identification data to be transmitted in the RF watermark signal of each transmitter shall be communicated to it through the `tx_address` and `network_identifier_pattern` fields of the Transmitter Control Packet.

The twenty-four bits of the combined `tx_address` and `network_identifier_pattern` fields shall represent the initialization value for a shift register code generator of the type shown in Figure 13.1. The initialization value shall be loaded into the shift register code generator during the Data Field and Data Frame Sync data segments, and the code generator shall operate according to the process described in Section 13.1.

6.5.2 Transmitter Data Signaling Control

To avoid the necessity of a separate remote control system for controlling transmitters, the TCP makes provision for communication of data to the transmitters to support several transmitter control functions. To provide a separate channel for status information from the transmitters in a network and for other applications, the RF watermark signal includes provision for modulation by a slow speed serial data stream inserted at each transmitter. Control of the modulation of the RF watermark signal is enabled by the 1-bit `tx_data_inhibit` field, which, when set to a value of one, inhibits the modulation of the RF watermark signal by the slow speed serial data. The coding and modulation processes for the slow speed serial data channel are described in Section 13.3.

6.6 Data Stream Frequency Reference

Section 9.6 requires the clock frequency of the Transport Stream to be locked to a precise external frequency reference from a GPS receiver. Locking the frequency in this way allows the data processing circuitry in slave exciters to restore the clock frequency more accurately and more easily than when a varying clock frequency must be tracked. The following paragraphs express the relationships between the defined bit rates and a precise frequency reference.

6.6.1 Relationship of Clock Frequency to Precise Frequency Reference

The relationship between a precise 10 MHz frequency reference and the clock frequency of the transport stream (as specified in A/53 Part 3 [2], Section 8.2) is expressed by

$$F_{CLK} = \frac{433998}{223795} \times 10^7 \text{ Hz} \quad (5)$$

Expressed another way, the formula (5) for the relationship between F_{CLK} and the 10 MHz reference frequency can be factored as

$$F_{CLK} = \frac{2 \times 3^5 \times 19 \times 47}{5 \times 11 \times 13 \times 313} \times 10^7 \text{ Hz} \quad (6)$$

The symbol clock frequency is related to the clock frequency of the transport stream (as specified in A/53 Part 3 [2], Section 8.2) by

$$F_{SYM} = \frac{313}{564} \times F_{CLK} \quad (7)$$

The highest common sub-multiple of the values of F_{CLK} and of the frequency reference, as would be used for the comparison frequency in a phase-locked loop locking one to the other, is found by

$$\frac{F_{CLK}}{433998} = \frac{10^7}{223795} = 44.68375075... \text{ Hz} \quad (8)$$

6.6.2 Transport Stream Bit Period

The fundamental unit of time used to define numerous parameters in this standard shall be the Transport Stream Bit Period, which is the reciprocal of the clock frequency of the transport stream. The period of one bit in the transport stream can be found from the reciprocal of the clock frequency of the transport stream, as defined in (5), or

$$\frac{1}{\frac{433998}{223795} \cdot 10^7} = 51.566 \times 10^{-9} \text{ seconds} \quad (9)$$

6.7 Data Addressed to Individual Transmitters

Within a Transmitter Control Packet, control data can be individually addressed to up to 16 separate transmitters. If more than 16 transmitters are in a network, TCPs can be sent with control data individually addressed to 16 transmitters at a time. Given the size of the address space and limitations in its use, a total of 4,095 transmitters can be accommodated in a single

network. Among control data that can be sent to transmitters individually are the delay offset, the power offset, and the transmitter identifier selection.

6.7.1 Transmitter Addressing

Transmitters within a network shall be individually assigned unique 12-bit addresses. The data within a TCP addressed to each transmitter shall begin with the address of that transmitter, as shown in Table 6.2.

6.7.2 Transmitter Group Indicator

The `tx_group_number` field shall carry the 8 msb's of the transmitter addresses included in the instance of the TCP. This redundant information may be used by transmitter data processing subsystems to more easily locate the data individually addressed to their associated transmitters and to add reliability to the determination of the addressing of information.

6.7.3 Transmitter Delay Offsets

The `tx_time_offset` fields shall carry the individual Offset Delay (OD) values for the transmitters associated with the `tx_address` fields preceding them. The values of `tx_time_offset` shall be formatted as prescribed in Section 6.4.4.

6.7.4 Transmitter Power Output

Transmitter power output shall be the effective radiated power (ERP), expressed in dB relative to 1 mW (i.e., dBm), from the antenna of the transmitter associated with the `tx_address` value immediately preceding, with the exception that a value of zero shall indicate no output. The power value shall be sent as 12 bits in the `tx_power` field in the section of the TCP addressed to the individual transmitter. The most significant 8 bits of `tx_power` shall carry the integer portion of the power value in the form of a hexadecimal (or binary) number. The least significant 4 bits of `tx_power` shall carry the fractional portion of the power value in the form of a hexadecimal (or binary) number. The maximum ERP that can be expressed with this method (in decimal notation) is +255.9375 dBm. Use of the range above 5 MW (+96.9897 dBm) is not expected. When set to zero, `tx_power` shall indicate that the transmitter to which the value is addressed is not currently operating in the network, and any transmitter associated with that `tx_address` shall mute (i.e., turn off) its RF output.

Note: A transmitter may or may not implement mechanisms to set its power level based upon the data contained in its associated `tx_power` field but shall cease transmitting upon receiving the value zero in that field.

6.7.5 Transmitter Identifier Levels

The `tx_identifier_level` fields shall indicate the ratios ("bury ratio") between the average power of the host 8-VSB signals and of the buried spread spectrum signals carrying the transmitter identifier, network identifier, and station signaling codes, as described in Section 6.5.1, for the transmitters identified by the preceding `tx_address` fields. The bury ratios shall be expressed in dB and shall be indicated by the enumerated values in the leftmost two columns of Table 6.3. The third column in Table 6.3 shows the combined transmitter output SNR at the several bury ratios when a transmitter having a base SNR of 30 dB is used. The fourth column shows the change in theoretical receiver AWGN threshold at the various bury ratios resulting from the combined output SNRs of column 3.

Table 6.3 Transmitter Identifier Bury Ratio

Bit Value	Bury Ratio	Tx SNR w/30	Rx Threshold
000	Identifier Off	30 dB	15.04
001	39dB	29.5	15.05
010	36 dB	29.0	15.07
011	33 dB	28.2	15.11
100	30 dB	27.0	15.18
101	27 dB ^a	25.2	15.32
110	24 dB ^a	23.0	15.63
111	21 dB ^a	20.5	16.30

^a It is recommended that bury ratios used during normal broadcast operations be chosen so as to result in a transmitter output signal-to-noise ratio (SNR) no less than 27 dB, as specified in ATSC A/64A. A bury ratio of 24 dB, for example, reduces the operating margin at the output of a transmitter from about 12 dB (with the recommended minimum of 27 dB transmitter S/N ratio) to about 7 dB. This may be sufficient reduction to cause some receivers to fail to receive the signal under certain circumstances.

6.8 Error Correction Coding

The Transmitter Control Packet payload shall be protected by Reed Solomon coding within the packet. Since there is no error protection provided within the MPEG-2 Transport Stream structure by itself and since the data in the packet provides synchronization information that cannot be protected by features of a repetitive nature, it is necessary to provide extra protection beyond that normally applied in the transport system between the Transmission Adapter and the transmitters.

6.8.1 Reed Solomon Coding

The first 164 bytes of the payload of the Transmitter Control Packet shall be protected by 20 bytes of Reed Solomon (RS) code placed in the last 20 bytes of the packet. The RS code used in the Transmitter Control Packet shall be a $t = 10$ (184,164) code. The RS data block size is 164 bytes, with 20 RS parity bytes added for error correction. A total RS block size of 184 bytes is transmitted per Transmitter Control Packet.

In creating bytes from the serial bit stream, the MSB shall be the first serial bit. The 20 RS parity bytes shall be sent at the end of the Transmitter Control Packet. The parity generator polynomial and the primitive field generator polynomial shall be as shown in Figure 6.6 of ATSC A/53 Part 2 [1]. The same design as used to RS code the 187-byte data segments in A/53 Part 2 [1] may be applied to the Transmitter Control Packet by stuffing additional bytes having a value of zero at the beginning of the data to be processed.

7. USE OF DUMMY DATA BYTES CHANNEL INFORMATION FOR SYNCHRONIZATION

An additional method¹² for carriage of M/H Frame alignment information may be used to transmit data through specific dummy data byte locations in every M/H Group for the purposes of identifying and aligning M/H Slot positions relative to VSB data fields and of synchronizing AT Tick Alignment Points with an external time reference, as specified in A/153 Part 2 [5], in the case of a single transmitter.

¹² This document requires inclusion of the Transmitter Control Packet in the transport stream even when the Dummy Data Bytes Channel signaling method is in use.

Dummy data bytes are placeholder bytes positioned in every M/H group, as defined in A/153 Part 2 [5], the locations of which are indicated therein by the value “2” in Table A.1: Group Format Before Data Interleaver. Dummy data bytes are assigned the fixed value 0xAF for emission. They can carry other data values over the STL, however, thereby creating a channel for signaling from the TA to the transmitter. In this case, signaling data bytes are inserted into dummy data byte locations at the input side of the STL. The signaling data bytes then traverse the STL and are recovered from the dummy data byte locations by the transmitter. Before emission, the data in the dummy data byte locations that carried other data are restored to the fixed value 0xAF.

When carriage of signaling data bytes in place of dummy data is employed, the dummy data byte positions used are those in the first five MHE transport stream packets (in TS packet #0 through TS packet #4) of each M/H Slot containing an M/H Group. The five specified packets together contain a total of 16 dummy data bytes, and these 16 byte positions are used for signaling over the STL. When used in this way, these 16 dummy data byte positions constitute the Dummy Data Bytes Channel.

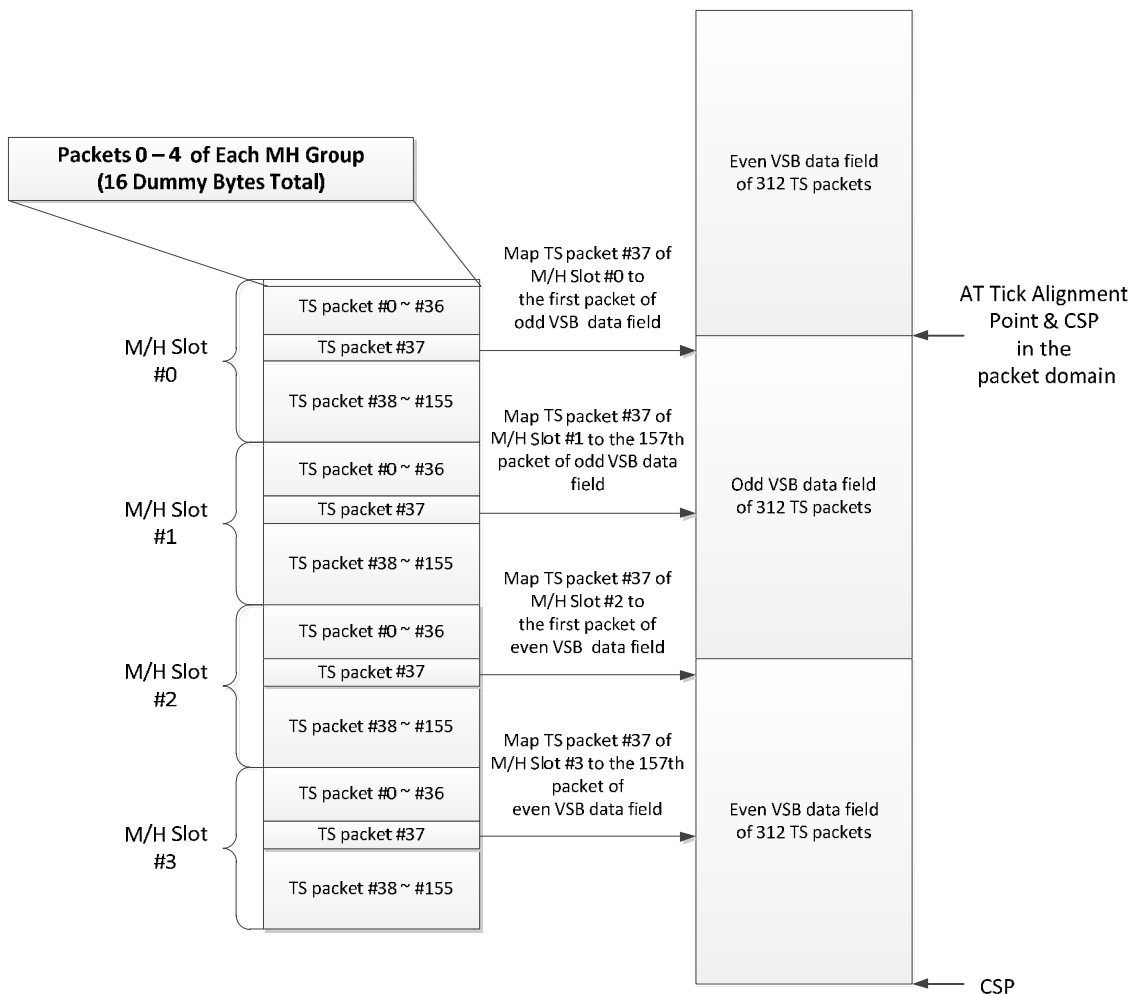

Figure 7.1 M/H Slot positioning relative to VSB data fields, showing locations of packets in which dummy byte locations are used to carry timing and control information. (Identical locations are used in each Slot but are not shown.)

The syntax and semantics for the Dummy Data Bytes Channel are defined in Section 7.2. Each M/H Group carries, in the dummy data byte locations, its absolute position in the current M/H Frame by using a combination of the Sub-Frame number and the Slot number.

In Figure 7.1 above, an M/H Group is shown in Sub-Frame #0, Slot #0. Signaling data are carried in the 16 dummy data byte positions of the first five packets of each M/H Group. These positions are required to be restored to the defined value for dummy data bytes prior to emission. Per A/153 Part 2 [5], there can be between 5 and 80 M/H Groups, occupying 5 to 80 M/H Slots in an M/H Frame. Data carried in the Dummy Data Bytes Channel appear only in Slots that carry an M/H Group within the data stream (i.e., where dummy bytes are defined to appear as per A/153 Part 2 [5]). Each M/H Group present in an M/H Frame is associated with a particular Sub-Frame number and Slot number, the values of which, when sent using the Dummy Data Bytes Channel, can be used for positioning the TS packets of that M/H Group relative to the VSB data field structure.

Per A/153 Part 2 [5], packet #37 in M/H Slots 0, 4, 8, and 12 is the first packet of an odd VSB data field; packet #37 in M/H Slots 2, 6, 10, and 14 is the first packet of an even VSB data field. Similarly, packet #37 in M/H Slots 1, 5, 8, and 13 is the 157th packet of an odd VSB data field; and packet # 37 in M/H Slots 3, 7, 11, and 15 is the 157th packet of an even VSB data field. The specified relationships between a packet number, M/H Slot number, and VSB data field can be used by the exciter to determine each CSP and AT Tick Alignment Point in the packet domain. These frequently-identified points also can be used (optionally) to improve the re-synchronization time of the exciter, such as when the input TS stream or utility power is briefly interrupted at the transmitter, etc.

To perform its normal M/H post-processing functions, an exciter must identify each M/H Group in the TS stream. There are two ways to accomplish this task. A sequence of 118 consecutive MHE packets (all having the assigned PID value for MHE packets) can be identified in the data stream as constituting an M/H Group. Once the M/H Group structure is identified, the first five MHE TS packets (packet #0 – packet #4) of each M/H Group will carry a segment of the Dummy Data Bytes Channel. Alternatively, the exciter can parse the transport stream for the first five packets having the PID value assigned to MHE packets following packets having some other PID value(s). This sequence identifies the first five packets of an M/H Group (and, correspondingly, the packets carrying the Dummy Data Bytes Channel). Note that, using either algorithm described above to locate the Dummy Data Bytes Channel, the CRC-C2 checksum (as defined in Section 7.2) sent in the last byte position (16) in each Dummy Data Bytes Channel segment should be used both to validate that the Dummy Data Bytes Channel is present and to detect bit errors in the initial 119 bits in the segment.¹³ (See Section 7.2 below for the normative provisions for the CRC-C2 data location and structure.)

The location in the transport stream of the next AT Tick Alignment Point (i.e., the first Cadence Sync Point in the next M/H Frame), in terms of the number of TS packets that will appear in the stream between the end of the last packet of the Slot in which the current M/H Group is located and the first CSP of the next M/H Frame, can be calculated as follows:

$$12,480 - (\text{sub_frame_num} * 156 * 16) + (\text{slot_num} * 156 + 119) \text{ TS packets} \quad (10)$$

¹³ To avoid weakening the detection capability of the CRC-C2 mechanism, the LSB of dummy byte position #15 (i.e., bit #120 in the segment) is not included in the CRC-C2 calculations.

The Dummy Data Bytes Channel shall be structured, by utilizing the 16 dummy data byte locations included in the first five MHE packets of each M/H Group, to carry active data in place of filler (“dummy”) data. The Dummy Data Bytes Channel data shall be packed into these dummy data byte locations sequentially, proceeding from the MSB to the LSB of the first dummy data byte location to be transmitted in the first of the pair of MHE packets, continuing from the MSB to the LSB of the second dummy data byte location in byte-transmission order, and progressing in this manner through the LSB of the last of the dummy data byte locations to be transmitted in the fifth packet of the M/H Group. (Note that the last byte position – #16 – carries the `crc_C2` field.) When present, the Dummy Data Bytes Channel shall exist only from the TA to the transmitter. (See Section 10.5 for data restoration requirements applicable to all transmitters, whether using the Dummy Data Bytes Channel information for transmitter synchronization or not.)

7.1 Calculation of CSP Back-Timing for Dummy Data Bytes Channel

To achieve a correctly timed emission, it is necessary to release the first CSP in each M/H Frame from the Transmission Adapter prior to the occurrence of the corresponding AT Tick by an amount of time equal to the total transit time through the complete system from Transmission Adapter output to antenna. The Dummy Data Bytes Channel uses the value of Maximum Delay, as defined in Section 6.4.2. Consequently, the provisions of Section 5.3 apply, including the requirements for back-timing the data release from the TA and the relationships expressed in Equations (3) and (4).

7.2 Syntax and semantics of Dummy Data Bytes Channel

The syntax and semantics of the signaling data of the Dummy Data Bytes Channel segment in each M/H Group shall be as shown in Table 7.1 and the text following the table. Those semantics that are the same as semantics defined in Section 6.2 are not repeated below. When the same parameters or semantic elements appear in both a TCP and the Dummy Data Bytes Channel segment within a single M/H frame, their values shall be identical with one another.

Table 7.1 Dummy Data Bytes Channel syntax

Syntax	No. of Bits	Format
Dummy Data_Bytes_Channel () {		
mode	1	bslbf
sub_frame_num	3	uimsbf
slot_num	4	uimsbf
dbc_synchronization_time_stamp	25	uimsbf
maximum_delay	25	uimsbf
num_mh_frame_periods	32	uimsbf
reserved	30	'0x3fffffff'
crc_C2	8	uimsbf
}		

sub_frame_num – A three-bit field that indicates the Sub-Frame number in which the current M/H Group resides. Its value shall have a range of 0 – 4.

slot_num – A four-bit field that indicates the Slot number in which the current M/H Group resides. Its value shall have a range of 0 – 15.

dbc_synchronization_time_stamp – A 25-bit field that carries an unsigned integer DBC STS value that indicates the time, measured in TS Bit Periods, between a GPS 1-second tick and the release from the TA of the start of the first bit of the MPEG-2 packet sync byte in the header of the first MHE packet of the current M/H Group. (See Section 7.3.)

maximum_delay – A 25-bit field that carries an unsigned integer Maximum Delay value that indicates the time delay setting in the system, measured in TS bit Periods, between the output time of a datum from the TA and the reference time of emission of the corresponding symbol from the transmitter. (See Sections 6.4.2 and 7.3)¹⁴

num_mh_frame_periods – A 32-bit field that carries an unsigned integer value indicating the number of M/H Frame periods since the epoch at the time of emission of the current M/H Group

crc_C2 – An eight-bit unsigned integer field that carries the value of a CRC Checksum (C2)¹⁵ calculated over the initial 119 bits in the segment, using the polynomial:

$$0x97 = x^8 + X^5 + X^3 + X^2 + X + 1 \quad (11)$$

7.3 Single Transmitter Dummy Data Byte Timing Control Data

The transmitter timing control function operates by the TA sending two time reference values in every M/H Group, carried, respectively, in the `dbc_synchronization_time_stamp` and `maximum_delay` fields defined in Section 7.2.

¹⁴ The value carried in the (25-bit) `maximum_delay` field is equal to the value represented by the combination of the `maximum_delay_base` (24-bit) and `maximum_delay_extension` (1-bit) fields defined in Section 6.2

¹⁵ Baicheva, T., S. Dodunekov, and P. Kazakov: “On the cyclic redundancy-check codes with 8-bit redundancy,” *Computer Communications*, Vol. 21, pp. 1030–1033, 1998. The polynomial known as (C2) with value $0x97 = x^8 + X^5 + X^3 + X^2 + X + 1$, is optimal for word lengths up to 119 bits. The LSB of dummy data byte position #15 is not used to carry data and is not included in CRC calculations to ensure that the optimal word length of 119 bits is not exceeded.

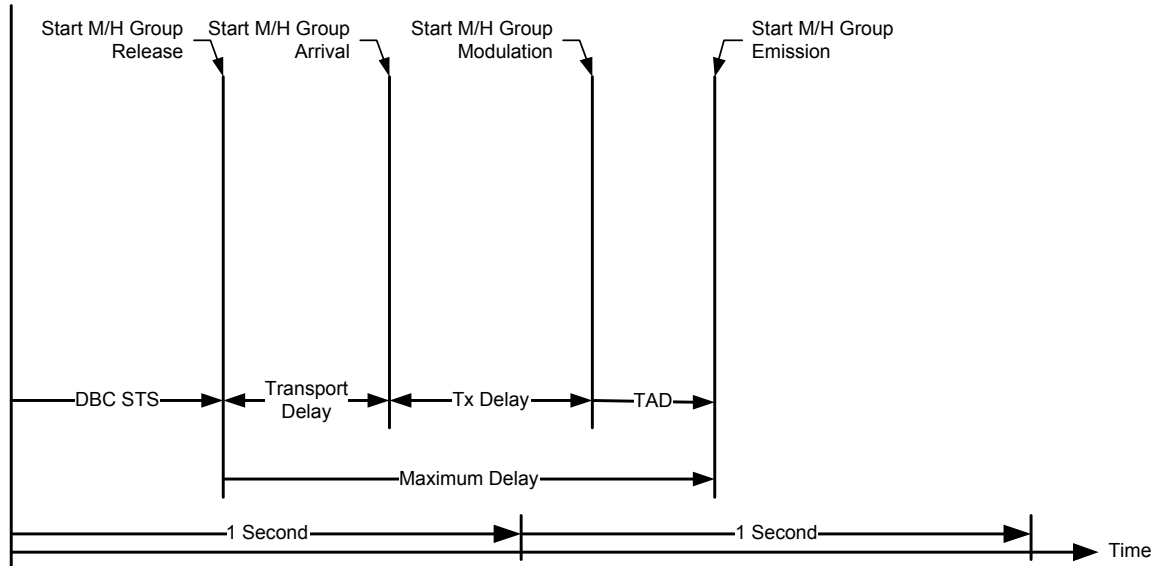

Figure 7.2 Single transmitter timing control relationships.

Figure 7.2 shows the timing relationships for a single transmitter under control of the Dummy Data Bytes Channel information.

The start of an M/H Group is released from the TA into the STL at the instant shown as "Start Of M/H Group Release" in figure 7.2. The `dbc_synchronization_time_stamp` field carries the DBC STS value in the M/H Group to indicate the time, measured in TS Bit Periods, between a GPS 1-second tick and the release from the TA of the start of the first bit of the MPEG-2 packet sync byte in the header of the first MHE packet of that M/H Group. The "Start Of M/H Group Arrival" instant also is shown, at which instant the exciter observes the arrival time, defined as the time between a GPS 1-second tick and the arrival at the exciter of the start of the first bit of the MPEG-2 packet sync byte in the header of the first MHE packet of the current M/H Group, measured in TS Bit Periods. The Transport Delay, in TS Bit Periods, for that Start Of M/H Group is given by:

If $\text{DBC STS} > \text{arrival time of Start Of M/H Group}$

$$\text{Transport Delay} = (\text{Arrival Time of Start Of M/H Group}) + 19392658 - (\text{DBC STS}) \quad (12)$$

Else

$$\text{Transport Delay} = (\text{Arrival Time of Start Of M/H Group}) - (\text{DBC STS})$$

The TX Delay value is given in units of TS Bit Periods by:

$$\text{TX Delay} = \text{MD} - (\text{Transport Delay} + \text{TAD})^{16} \quad (13)$$

Note that TX Delay correlates to the size of the FIFO Buffer required in the exciter (once account is taken of all implementation-specific internal delays). The (Start Of M/H Group

¹⁶ See Section 6.4.3 for the definition of Transmitter and Antenna Delay (TAD).

Modulation) is the instant at which the (Start Of M/H Group)¹⁷ is removed from the exciter FIFO Buffer and is input to the Data Randomizer.¹⁸ The instant of Start Of M/H Group Modulation, in TS Bit Periods since the last GPS seconds tick, is given by:

$$(\text{Start Of M/H Group Modulation}) = (\text{DBC STS} + \text{MD} - \text{TAD}) \bmod 19392658 \quad (14)$$

Finally, the instant at which the (Start Of M/H Group) is emitted, in TS Bit Periods since the last GPS seconds tick is labeled (Start Of M/H Group Emission) and is given by:

$$(\text{Start Of M/H Group Emission}) = (\text{DBC STS} + \text{MD}) \bmod 19392658 \quad (15)$$

Note that the timing chain shown in Figure 7.2 and described in this section operates independently of ATSC Time and therefore requires that the Transmission Adapter output be synchronized to ATSC Time as described by equation (4)

8. TRANSMITTER MODE CONTROL DATA AND SIGNALING

The ATSC Digital Television Standard A/53 defines 24 symbols in the Data Field Sync data segment to indicate the VSB Mode that is transmitted. Immediately following the VSB Mode symbols, A/53 also defines an additional 92 symbols (DFS Reserved symbols) that are set aside for various applications such as signaling the presence of enhanced data transmission (per A/53) and providing additional known data sequences (such as those defined in A/153). Those symbols can be used not only to inform receivers of the mode being transmitted and of enhanced data transmission in the emission but also to control the mode of operation adopted by the transmitter(s) in a system. It is beyond the scope of this document to define the uses of the VSB Mode and DFS Reserved symbols, but the transmission of their values, along with those of certain additional (field-rate) bits, to transmitters for purposes of control is defined hereinafter.

8.1 Field-Rate Side Channel Data

The values of the VSB Mode symbols and symbols 1 through 92 of the Reserved symbols defined in A/53 Part 2 [1] (as numbered according to Section 6.5.2.4 therein) and specified in A/53 Part 2 [1] or A/153 Part 2 [5], as well as other control information, shall be carried to the transmitter(s) in a network using the Field-Rate Side Channel defined in Sections 8.2 and 8.3. Collectively, the data in the VSB Mode symbols, the DFS Reserved symbols, and the additional field-rate bits are designated the Transmitter Mode Control Data. The Transmitter Mode Control Data shall be used to set the operating mode of each transmitter and to provide other control functions that must be followed by all transmitters in unison. The Transmitter Mode Control Data control the symbols emitted in the immediately following Data Field Sync data segment and become effective in the operating mode of the transmitter(s) at the end of the next complete data field subsequent to completion of delivery of the data to the transmitter(s). In other words, the second Data Field Sync data segment following delivery of the changed data to the transmitter(s) shall be the first data segment to adopt the new mode of operation.

¹⁷ I.e., the start of the first bit of the MPEG-2 packet sync byte in the header of the first MHE packet of the current M/H Group

¹⁸ The Input of the data randomizer in the exciter is the reference point for measurement of delay through the transmission system, see Section 6.4.3

Data to be carried in the Field-Rate Side Channel shall be formatted according to Table 8.1 and the semantics that immediately follow Table 8.1. The bits of the *vsb_mode_data*, the *dfs_reserved_data*, and the other Field-Rate Side Channel data fields are formatted into 23 bytes. The msb of the *frsc_sync_word* data field shall occupy the msb of the first byte to be sent, followed by successive bytes carrying the bits in the order in which they will be emitted, from msb to lsb of each succeeding byte. The *vsb_mode_data* (to be emitted) are followed by the *dfs_reserved_data* (to be emitted), which, in turn, are both preceded and followed by the other Field-rate Side Channel data (not to be emitted), thereby filling all 23 bytes.

The 23 bytes of Field-Rate Side Channel data shall be protected by 16 bytes of Reed Solomon error correction coding applied in the manner described in Section 6.8.1 and carried in *side_channel_ECC* as defined in Table 8.1 and the following semantics. The RS code used in the Field-Rate Side Channel shall be a $t = 8$ (39,23) code. The RS data block size is 23 bytes, with 16 RS parity bytes added for error correction. A total RS block size of 39 bytes shall be transmitted per data field (i.e., 312 MPEG-2 transport stream packets). The total of 39 bytes to be transmitted in the Field-Rate Side Channel represent 312 bits of data that are carried in the Field-Rate Side Channel.

Table 8.1 Field-Rate Side Channel Data Organization

Syntax	No. of Bits	Format
Field-Rate Side Channel () {		
frsc_sync_word	16	x'B847'
frsc_version	5	bslbf
reserved	3	'111'
system_mode	4	bslbf
post_processor_control_active	1	bslbf
reserved	3	'111'
active_communications_channels()		
TCP_active	1	bslbf
dummy_data_bytes_active	1	bslbf
training_channel_active	1	bslbf
reserved	2	'11'
primary_communications_channel	3	bslbf
VSB_mode_data	24	bslbf
dfs_reserved_data	92	bslbf
post_processor_control	16	bslbf
reserved	12	bslbf
side_channel_ECC	128	uimsbf
}		

frsc_sync_word – A 16-bit field that carries a synchronization word to indicate the start of an FRSC Packet. This field shall contain the value 0xB847; note that this sequence also may occur randomly in other locations within the Field-Rate Side Channel bit stream.

frsc_protocol_version – A five-bit unsigned integer field that represents the version of the structure of the FRSC syntax. The two most-significant bits are the major version level; the three least-significant bits are the minor version level, to be interpreted as follows: A change in the major version level shall indicate a non-backward-compatible level of change. A change in the minor version level, provided the major version level remains the same, shall indicate a

backward-compatible level of change. The initial value for this field shall be '00000'. The values of the two MSB bits or the three LSB bits each shall be monotonically incremented separately, as needed depending upon the type of change of the FRSC protocol.

Note: The `frsc_protocol_version` field should be parsed before attempting to parse the other fields.

system_mode – A four-bit field that indicates the mode in which the transmission network is operating. In the event of A/153 M/H operation, this field shall indicate the presence of M/H data in the stream. Its value shall continue to indicate the presence of M/H data during intervals when no M/H data are present in the stream but will be present within a period eight M/H Frames following the current M/H Frame. This value can be used to control signaling of the presence of M/H data in the emission.

The values of the `system_mode` field shall have the meanings given in Table 8.2. The System Modes indicated by the enumerated values shall be those defined in Section 6.2, the semantic elements related to which are listed in the five right-most columns in Table 6.2.

Table 8.2 System Mode Field Values

Value	System Mode	MH Present
x0	Legacy SFN (a/110b)	
x1	MFN (non-MH)	
x2	SFN (non-MH)	
x3-x8	reserved	
x9	MFN MH (a/153)	X
xA	SFN MH (a/153)	X
xB	MFN reserved	X
xC	SFN reserved	X
xD-xF	reserved	

post_processor_control_active – A one-bit field that indicates whether the `post_processor_control` field bits are active in the packet. A '0' shall indicate that the bits are active; a '1' shall indicate that the `post_processor_control` bits are not active. The value of this field shall be set to '1'.

active_communication_channels – A group of three bits, each of which indicates whether a particular communication channel is being transmitted by the TA. The three bits shall indicate the status, respectively, of data in the Transmitter Control Packet, Dummy Data Bytes Channel, and Training Channel¹⁹ data communications mechanisms in the transport stream. A '1' shall indicate the presence of data in the channel indicated by the bit; a '0' shall indicate that the respective channel is not carrying data from the TA.

primary_communication_channel – A three-bit field that indicates the primary communication channel between the TA and the transmitter(s). The values of the `primary_communication_channel` field shall have the meanings given in Table 8.3

¹⁹ The Training Channel indicator is reserved for signaling the presence of a method for carrying data using an alternative transport method in the future.

Table 8.3 Primary Communication Channel Field Values

Value	System Mode
x0	Transmitter Control Packet
x1	Dummy Bytes Data Channel
x2	Training Channel
x3-x7	Reserved

Note: This field is intended to provide ambiguity resolution in the event that multiple communication methods are active in the data stream.

VSb_mode_data – A 24-bit field of data (as defined in A/53 Part 2 [1]) that indicates the mode setting of the transmitter(s). Transmitters shall use the data to populate the VSb_mode symbols transmitted during Data Field Sync data segments and may use the data to control their modes of operation .

dfs_reserved_data – A 92-bit field of data (as defined in A/53 Part 2 [1] and A/153 Part 2 [5]) to be inserted into the "Reserved" symbols transmitted during Data Field Sync data segments. Transmitters shall use the data to populate the dfs_reserved symbols transmitted during Data Field Sync data segments and may use the data to control their modes of operation .

post_processor_control – A 16-bit field that can contain post-processor control values. If the post_processor_control_active field has a value of '1', it shall be filled with a pattern of all '1's. If the post_processor_control_active field has a value of '0', these bits can take on values yet to be defined.

side_channel_ECC – A 128-bit unsigned integer field that carries 16 bytes of Reed Solomon error correcting code used to protect the remaining 23 payload bytes of the Field-Rate Side Channel (including the 2-byte FRSC sync word that begins the sequence).

8.2 Field-Rate Side Channel Format

A Field-Rate Side Channel shall be structured by utilizing one bit from each of the 312 packets comprising a data field. The bit used shall be the one normally carrying the transport_error_indicator field defined in MPEG-2 Systems. The Field-Rate Side Channel shall exist from the TA to each of the transmitters. Transmitters shall restore the state of the transport_error_indicator field to a value of '0' after extracting the information carried in the side channel. The data to be carried in the Field-Rate Side Channel shall be synchronized with the regular procession of Cadence Sync Points such that the msb of the first byte of side channel data is transmitted in the transport_error_indicator field of the packet immediately following a Cadence Sync Point. The lsb of the last byte of the Reed Solomon error correction coding shall be carried in the transport_error_indicator field of the last packet preceding a Cadence Sync Point.

8.3 Bits for Data Field Sync Transmission

The VSb_mode_data and the dfs_reserved_data bits (sent through the Field-Rate Side Channel) shall be transmitted by the transmitter(s) in a system in the Data Field Sync data segment in the locations of the VSb Mode and the Reserved symbols defined in A/53 Part 2 [1], Section 6.5.2. Bit values of zero shall result in symbols of -5 on odd data fields (positive PN63 in the preceding structure), and values of one shall result in symbols of +5 on odd data fields. The reverse shall be true on even data fields.

Any changes occurring in the `VSB_mode_data` and the `dfs_reserved_data` bits are required to be emitted in the first Data Field Sync data segment following delivery of the changed data to the transmitters. This timing provides a delay of one data field period between initial emission of the corresponding changed `VSB_mode_data` and/or `dfs_reserved_data` symbols and the time at which the transmitters actually adopt any new mode, to provide time for receivers to prepare for the mode change.

9. TRANSMISSION ADAPTER

As shown in Figure 4.6 and described previously, the transmitter synchronization system comprises a Transmission Adapter (TA) at the source end of a studio-to-transmitter link (STL) combined with data processing subsystems at the transmitter(s) that are capable of responding to the synchronization signals inserted into a standard MPEG-2 Transport Stream by the Transmission Adapter. When M/H (A/153) operation is included, the TA is associated with the M/H Multiplexer shown in Figure 4.2. It incorporates the M/H post-processor functionality into its data processing model, as is described below. When Distributed Translators are used, as shown in Figure 4.7 and described previously, a Transmission Adapter at the source end of the network conceptually is dedicated to each tier of translators and performs essentially the same functions as described for a network of Distributed Transmitters; differences will be described in this section.

The Transmission Adapter (TA) performs the functions of inserting into the TS the fully-formed Transmitter Control Packet, optionally the Dummy Data Bytes Channel, and the Field-Rate Side Channel, described in the previous three major sections of this standard. It substitutes the necessary TCP data into a packet with the appropriate PID and `OM_type` values supplied to it as a service by the main service multiplexer or by the M/H packet mux or that it inserts into the stream itself. It inserts into the bits of the Field-Rate Side Channel the data to be transmitted in Data Field Sync data segments and other control information. In M/H operation, when the Dummy Data Bytes Channel is used, it inserts control information into the locations of the dummy data bytes. It provides the necessary buffering to support the relative timing of the trellis code states, the appearance of the TCP in the Transport Stream, and the back-timing necessary to obtain M/H emission synchronized with ATSC Time ticks. It also provides the necessary buffering to support maintenance of the transmitter frequencies to the necessary precision on both a static and dynamic basis.

The substitution of TCP data into an appropriate packet takes place in two stages. First, all the data other than the Trellis Code States and the Reed Solomon coding are inserted. The data then in the TCP is next processed through a data processing model along with the other data in the data stream. The second stage of TCP data substitution then inserts the Trellis Code States and the Reed Solomon coding immediately prior to distribution of the TCP to the transmitters. At each transmitter (after stripping the Trellis Code States and the RS coding for purposes of synchronizing the transmitter) default data, bit-wise identical to that originally supplied by the main service multiplexer, the M/H packet mux, or the TA, are reinserted in their places prior to data processing in the transmitter. The TCP data originally inserted by the TA in the first stage is broadcast as received through the distribution system. The two-stage process is employed in order to allow broadcasting of the bulk of the TCP data for use by test and measurement or network management equipment. It also may be of use to receivers.

A conceptual example of a Transmission Adapter is shown in block diagram form in Figure 9.1. In that figure, only the portions of the Transmission Adapter necessary to produce the Transmitter Control Packet are shown. The buffering processes for maintenance of transmitter

frequencies are not shown, nor is the method for inserting TCP placeholder packets. Not shown are the mechanisms for creating and inserting data into the Field-Rate Side Channel and the Dummy Data Bytes Channel. Also not shown are the mechanisms for determining the information used for transmitter timing adjustment, for transmitter power adjustment, for transmitter mode and identifier control, and for substitution of the reserved bits in the Data Field and Data Frame Synchronization data segments.

Figure 9.1 Transmission Adapter (conceptual) [see *next page*].

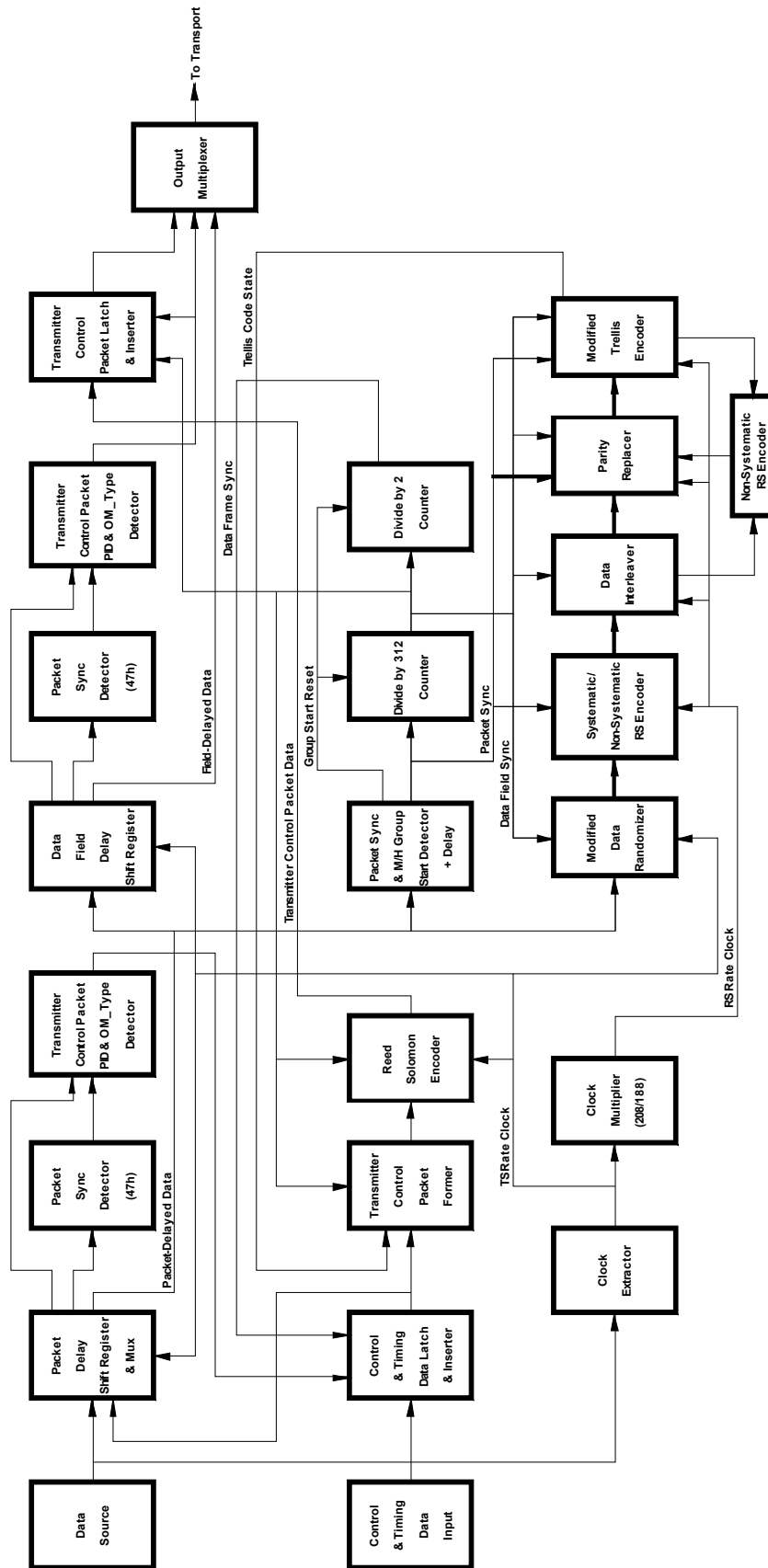

9.1 Model Data Processing Subsystem

To achieve the objectives outlined for it, the Transmission Adapter includes a model of the data processing subsystem of an 8-VSB M/H modulator as defined in ATSC A/153. When operating in standard (non-M/H) 8-VSB mode, the data processing subsystem free-runs, establishing the various timing relationships between the input Transport Stream to be transmitted and the several processes that occur in a transmitter. When operating in M/H mode, the data processing system locks to the data to be transmitted, establishing the various timing relationships between the input Transport Stream to be transmitted, a timeline derived from an external time reference, and the several processes that occur in a transmitter. Data then can be extracted from the data processing model, inserted into the Transport Stream, and used to synchronize or slave the equivalent functions in the actual transmitter(s) in the network. When standard (non-M/H) 8-VSB data streams are processed, the data processing subsystem remains in its main service mode full time, and the data processing model functions exactly as would a standard 8-VSB data processing system of the type defined in ATSC A/53.^{20, 21}

9.1.1 All Systems Prior to Symbol Mapping

In Figure 9.1, the bottom row of blocks plus the right-hand three blocks of the middle row comprise most of the data processing elements of an 8-VSB M/H (A/153) modulator subsystem. Missing are the data segment and data field sync insertion blocks, the 313/312 clock multiplier that compensates for the addition of the Data Field Sync and Data Frame Sync data segments, the mapper, and the modulator per se. Included are the packet sync and M/H Group start detector and delay, divide by 312 counter, and divide by 2 counter that together establish the relationships between the incoming Transport Stream packets and the Data Field Sync and the Data Frame Sync signals. Also present are all of the data processing elements up through the modified trellis encoder that allow the establishment of a trellis code trajectory to which all of the trellis encoders in the transmitter(s) can be slaved.

9.1.2 Establishes References for Transmitters

The model data processing subsystem included in the Transmission Adapter establishes a timing relationship between each of the included processing functions and the Transport Stream that is to be delivered to the transmitter(s). It then allows extraction of information about that timing relationship that can be sent to the transmitter(s) along with the Transport Stream data. The information sent to the transmitter(s) allows the equivalent processing functions in the transmitter(s) to adopt the same relationship to the Transport Stream data as was established in the Transmission Adapter. When the transmitter(s) adopt(s) the same relationship to the Transport Stream data, it/they will produce identical symbol outputs for the same Transport

²⁰ When it is desired to transition back and forth between operations in M/H mode and in 8-VSB mode, the TA and transmitter(s) can transition between the two modes while avoiding an interruption to received signals due to a reset of system timing. Such transitions require that the emissions maintain the correct relationship to the ATSC Time timeline during periods of 8-VSB-only (i.e., non-M/H) transmission.

²¹ Earlier versions of this standard specified a data processing model that matched the one defined in A/53 Part 2 [1]. Users should note that an update is required to Transmission Adapters built to the original specification if M/H operation is required and that such updated TAs will not be compatible with slave exciters built to the original specification unless they, too, are updated to the provisions of this version of this standard.

Stream data input and thereby effectively become synchronized with the data processing model (and with one another when more than one transmitter is used).

Two sets of synchronization information effectively are sent from the model data processing subsystem in the Transmission Adapter to the transmitter(s): data indicating the locations of a procession of Cadence Sync Points (CSPs) and data carrying Trellis Code State information.

9.1.2.1 Procession of Cadence Sync Points

The combined states of the concatenated divide-by-312 and divide-by-2 counters shall indicate the locations of a procession of Cadence Sync Points in the Transport Stream at those instants when the pair of counters transitions from a total count of 624 to a count of zero. The pair of counters shall be clocked by the occurrence of packet sync words in the Transport Stream. As defined in Section 5, Cadence Sync Points indicate the locations in the Transport Stream at which Data Field Sync segments with non-inverted middle PN-63 data sequences are inserted. For standard 8-VSB transmission per A/53, at the Transmission Adapter, the data frame cadence may be of random phase with respect to the Transport Stream data,²² although synchronized with the packet sync words; at the transmitter(s) the phase of the data frame cadence matches the phase established at the Transmission Adapter. For M/H transmission per A/153, the data frame cadence is required to adopt the phase relationship to the Transport Stream data defined in Section 9.1.2.2.

The locations of the procession of Cadence Sync Points are signaled to the transmitter(s) by data included in Transmitter Control Packets and the Dummy Data Bytes Channel, when present. Not every Cadence Sync Point will be signaled by either method, depending upon the timing of insertion of the different data carriage methods. The Cadence Sync Point timing indicated by the two data carriage methods originating from a single TA, however, shall be derived from the same pair of concatenated counters and shall point to the same locations in the Transport Stream for the Cadence Sync Points.

9.1.2.2 M/H Data Structure to Cadence Sync Point Relationship

For M/H transmission per A/153 Part 2 [5], the Cadence Sync Points occur at the start of the 38th packet (packet 37) of Subframe 0, Group 0, and at the start of the 38th packet (packet 37) of every fourth group thereafter; i.e., Cadence Sync Points occur at the start of the 38th packets of Groups 0, 4, 8, and 12 of each M/H Subframe. In M/H-mode operation, the Transmission Adapter shall determine the locations of the starts of the 38th packets of the respective Groups and shall reset the concatenated divide-by-312 and divide-by-2 counters at the starts of the packet sync words of the respective packets. The Transmission Adapter may determine the locations of the required synchronization points by decoding and parsing the Transmission Parameter Channel (TPC) of the M/H data appearing at the input of its post-processor data model (in the block shown as the packet sync and M/H Group start detector plus delay in Figure 9.1). For systems in which the M/H Multiplexer of Figure 4.2 is integrated with the Transmission Adapter, it may be possible to use a separate connection to flag the occurrence of the correct locations in the data stream for the Cadence Sync Points.

9.1.2.3 Trellis Code State Information

The Trellis Code State information carries the states of all three memory elements of each of the twelve conceptual trellis coders used in the data processing subsystem of the modulator. As defined in Section 6.3.1, the 36 bits of information indicate the states of the trellis coders at the

²² But see Footnote 21.

beginning of the first data segment following the next occurrence of a Data Field Sync data segment (i.e., following the next Cadence Sync Point). At the Transmission Adapter, the trellis code state is random with respect to the Transport Stream data; at the transmitters its state is not random, matching the state of the trellis coders established at the Transmission Adapter.

In the Transmission Adapter, the Data Field Delay Shift Register delays the entire Transport Stream by a period of one data field. The delay allows the state of the trellis coders at the end of a data field to be inserted into a Transmitter Control Packet contained within the same data field. The Data Field Delay Shift Register also provides the ability to look ahead at the data before it is output to the Output Multiplexer in order to anticipate various events.

9.2 Transmitter Control Packet Formation

As previously described, the formation of the Transmitter Control Packet takes place in two stages within the Transmission Adapter. First, a Precursor Packet with the appropriate PID and OM_type values, stuffed with the pre-defined payload data sequence, is received from a multiplexer in the upstream system, or it can be generated in the TA itself (to replace a null packet in the incoming data stream). All of the data other than the trellis code states and the Reed-Solomon error correcting codes are inserted into the packet at the beginning of the TA processing chain. The packet is then passed through the data processing model already described and contributes to the formation of the trellis codes. When the TCP appears in the delayed output of the TA, the trellis code and Reed Solomon information are inserted to complete the packet prior to its distribution to the transmitters. How all of this takes place is described in this section.

9.2.1 Transmission Adapter Processing

The top row in Figure 9.1 plus the left-hand four blocks of the middle row include the additional processing elements that are necessary to convert a Precursor Packet having the PID and OM_type values reserved for transmitter control into a Transmitter Control Packet. On the top row, they are two shift registers, one having a delay of one packet period and one having a delay of one data field period, two packet sync detectors, two detectors for the PID and OM_type values reserved for transmitter control, a latch for trellis code state data and an inserter to output that data to a multiplexer at the correct time, and an output multiplexer capable of replacing the data in the payload of the designated packet. On the middle row, they are the source of control and timing data, a control and timing data latch and inserter, a Transmitter Control Packet former, and a Reed Solomon encoder. The operations of the respective additional processing elements are discussed in Section 9.2.3.

9.2.2 Transmitter Control Packet Pre-Processing Payload

Because the same data must be processed by the data processing subsystems in the Transmission Adapter and in the transmitter(s) in order to establish and maintain synchronization, it is necessary to assure that, when data is substituted in the delivery channel, the data that was processed at the Transmission Adapter is reinserted at the transmitter(s). The way to meet this requirement is to use known values at the Transmission Adapter and at the transmitter(s) for the data that will be substituted in the delivery channel. Thus, the payload data of the packets identified by the PID and OM_type values reserved for transmitter control shall be as specified in this section when delivered to the Transmission Adapter for processing. Specified portions of the packet are returned to their initial states prior to data processing at the transmitter(s), and, when such restoration of the initial states is required, the patterns defined in this section shall be followed.

9.2.2.1 Fixed Packet Payload Values

The payloads of the Precursor Packets identified by the PID and OM_type values reserved for transmitter control shall have fixed values when delivered to or generated in the Transmission Adapter. Most or all of the payload data will be replaced in the TA prior to delivery to the transmitters. During transport between the Transmission Adapter and the transmitters, the payloads shall carry the transmitter control data values defined in Section 6. Upon processing for transmission, the original, fixed payload data values shall be substituted for those portions of the transmitter control data carried during transport that are not to be transmitted.

9.2.2.1.1 Fixed Values

Fixed values of data shall be carried in the 3rd through 14th and the 165th through 184th payload bytes of Precursor Packets and of partially processed Transmitter Control Packets (i.e., of TCPs into which the Trellis Code State data and the ECC code data is yet to be inserted). The fixed values shall consist of all '1's (i.e., bytes having a value of 0xFF). The specified bytes are those that are required (in Section 10.3.1 herein) to be restored to the same defined values (all '1's) by the transmitter(s) prior to emission.

9.2.3 Transmitter Control Packet Payload Substitution

As described previously, substitution of the payload of the packet reserved for transmitter control takes place in two stages. The first stage occurs in the three blocks to the right of the Data Source in the top row of Figure 9.1 and in the first block to the right of the Control and Timing Data Input in the second row. In the top row, the data is fed through a Packet Delay Shift Register and Multiplexer. Connected to the shift register so as to look ahead into its contents are a Packet Sync Detector and a Transmitter Control Packet PID Detector. When the latter two devices detect a packet sync word and the appropriate PID and OM_type values, they trigger the Control and Timing Data Latch and Inserter on the second row of Figure 9.1. It, in turn, inserts data back into the Packet Delay Shift Register and Multiplexer. That data replaces the fixed values of the Precursor Packet with all the necessary payload data, other than the trellis code state data and the Reed Solomon coding data, to form a Transmitter Control Packet at the same place in the data stream at which the Precursor Packet was positioned. The output of the Packet Delay Shift Register and Multiplexer is then fed to the blocks in the right half of Figure 9.1 for the second stage of data insertion.

When the Control and Timing Data Latch and Inserter forms its portion of the payload of the TCP, it sends a copy of it to the Transmitter Control Packet Former. That device adds the Trellis Code State data to form a complete Transmitter Control Packet without the Reed Solomon coding. Its output then goes to a Reed Solomon coder, where the necessary error correction coding is calculated and added to the packet. The packet is then stored in the Transmitter Control Packet Latch and Inserter on the right end of the top row of Figure 9.1.

9.2.4 Transmitter Control Packet Formation for Distributed Translators

When Distributed Translators are used in a multi-tier network, multiple data processing models are used to form the Transmitter Control Packets addressed to the several tiers of DTxRs and identified by corresponding OM_type field values. So that all of the Control and Timing Data intended for each of the tiers of transmitters and translators can be received from any transmitter in the network, it is necessary that all of the Control and Timing Data be processed through all of the cascaded data processing models. Formation of the TCPs as described in Section 9.2.3, for all of the tiers, with corresponding OM_type values as described in Section 6.1.2, shall be carried out prior to the first data processing model in the cascade. In this manner, all of the data addressed to

all of the transmitters will pass through all of the data processing models in the chain and can be correctly transmitted from all of the transmitters and translators in the network.

9.3 Transmitter Control Packet Insertion Rate

The Transmitter Control Packet insertion rate into the Transport Stream will depend upon a number of factors. It shall be inserted at the rates and under the conditions described in this section.

9.3.1 Minimum Insertion Rate

No minimum insertion rate for Transmitter Control Packets is specified. The minimum insertion rate should be set for each system based upon a balance of the overhead data capacity required for transmitter synchronization and the recovery time for any given transmitter following an error in the synchronization process. By way of example, an insertion rate of one TCP per second would utilize approximately 0.0078 percent of the overall data capacity of the channel.

9.3.1.1 Service of Upstream Multiplexer

Insertion of transmitter control Precursor Packets, having the fixed payload described above, that will be turned into Transmitter Control Packets by the Transmission Adapter shall be a service provided by a multiplexer or similar device upstream of the Transmission Adapter. This requirement is necessary to assure the occurrence of such packets at the desired insertion rate and properly coordinated with the other data in the stream.

9.3.1.2 TA Packet Insertion with No Input

When no input is received by the Transmission Adapter from an upstream multiplexer, the TA shall create at its input a stream of MPEG-2 Transport Stream null packets, having a bit rate of as specified precisely in A/53 Part 2 [1] (approximately 19.39 Mb/s). It shall insert into that stream, at a rate of approximately one per second, transmitter control Precursor Packets suitable for conversion to Transmitter Control Packets. The requirement noted in this paragraph is for the purpose of keeping the Distributed Transmission System operating and synchronized even when there is no input to the TA.

9.3.2 Maximum TCP Insertion

There shall be no more than one TCP per transmitted 8-VSB data field.

9.4 Transmitter Control Packet Payload Substitution

When packets having the PID and OM_type values reserved for transmitter control appear in the Transport Stream, they shall have their payloads substituted by the Transmission Adapter with the data necessary to form a Transmitter Control Packet. The data substitution is done in such a manner as to process all the data but the trellis code state data and the Reed Solomon ECC through the data processing model. This includes them in the formation of the trellis code trajectory and allows them to be broadcast by the transmitters.

Upon entry of Precursor Packets having the transmitter control PID and OM_type values into the TA, they shall be stuffed with all '1's in the 2nd through 184th bytes of the packet payload. Those portions of the stuffed data required by Section 6.2 to be populated with data shall be replaced with all of the information to be transported in the TCP, except for the 3rd through the 14th and the 165th through 184th payload bytes of the packet, at this stage. Those bytes will carry the trellis code states and the Reed Solomon ECC, respectively, and will be substituted later in the process. Any bytes not carrying information in any particular instance of the TCP

shall retain the stuffing code pattern that originated in the upstream multiplexer (or that was created by the TA in the absence of input).

In the conceptual TA design of Figure 9.1, the substitution for the stuffing pattern of the data to be sent to the transmitters (other than the trellis code states and the Reed Solomon ECC) occurs in the Packet Delay Shift Register and Multiplexer near the left end of the top row. The substitution takes place when the Packet Sync Detector and the Transmitter Control Packet PID Detector, just to the right of the packet delay block, determine that a packet having the appropriate PID and OM_type values is contained in the shift register in the correct position. At that time, the data stored in the Control and Timing Data Latch and Inserter is substituted for the stuffing pattern. The substituted data then proceeds along with the existing header for the packet in the normal sequence of packets through the remainder of the data processing within the TA. Since the data substituted into the packet at this point passes through the portion of the TA data processing that includes the trellis code generation, the transmitter(s) must transmit such substituted data in order to result in matching trellis code trajectories, thereby keeping the transmitter(s) locked to the processes in the TA (and consequently to one another when multiple transmitters are used).

Again in the conceptual TA of Figure 9.1, the trellis code states and the Reed Solomon ECC data are substituted into the 3rd through the 14th and the 165th through the 184th payload bytes, respectively, of the TCP, near the end of the TA data processing chain. The trellis code states and Reed Solomon ECC are stored in the Transmitter Control Packet Latch and Inserter in the upper right corner of the figure. The substitution takes place when the Packet Sync Detector and the Transmitter Control Packet PID Detector, just to the right of the Data Field Delay Shift Register in the middle of the top row, determine that a packet having the appropriate PID and OM_type values is contained in the shift register in the correct position. At that time, the Output Multiplexer substitutes the data stored in the Transmitter Control Packet Latch and Inserter for the stuffing pattern in the appropriate positions within the packet. Alternatively, the entire payload of the TCP can be stored in the Transmitter Control Packet Latch and Inserter and then substituted for the data in the packet. This latter approach will overwrite the data that was previously substituted at the beginning of the TCP processing, but the overwriting will be with the same data. The trellis code states and Reed Solomon ECC data will be part of the substituted information. Any portions of the packet not actually containing data to be substituted will have to retain or be stuffed again with the correct stuffing pattern.

9.5 Field-Rate Side Channel Construction and Insertion

The Transmission Adapter shall create a Field-Rate Side Channel by utilizing the transport_error_indicator fields in the packets of the outgoing MPEG-2 TS as a serial bit stream. Data in the Field-Rate Side Channel shall be synchronized to the Cadence Sync Point procession as defined in Section 8.2. The data carried in the Field-Rate Side Channel shall be that specified in Section 8.1.

9.5.1 Field-Rate Side Channel Insertion with No Input

When the Transmission Adapter receives no input from an upstream multiplexer, the TA shall create a Field-Rate Side Channel using the transport_error_indicator fields in the null packets that it creates at its input under such conditions, as specified in Section 9.3.1.2. When the TA receives no input of VSB_mode_data or dfs_reserved_data, it shall transmit, in the bits reserved for those fields, data that will trigger the transmission of symbols identical to the symbols specified by A/53 Part 2 [1], Section 6.5.2.3 for transmission in the VSB Mode symbols and Section 6.5.2.4

for transmission in the Reserved symbols of the Data Field Sync data segment. When the TA receives no input, it also may insert data, per Section 8.1, that will trigger the transmission of symbols of the type specified in A/53 Part 2 [1], Section 6.5.2.6 to signal the transmission of enhanced data, as appropriate for the emission mode of the transmitter(s).

9.6 Transport Stream Output Frequency Stability and Accuracy

The bit rate of the Transmission Adapter output Transport Stream shall be that specified in Section 6.6 by Equation 5 and shall be derived from a precise frequency reference disciplined to the reference frequency of the Global Positioning System (GPS). When in an M/H (A/153) mode of operation, the data stream at the TA input is required to match the bit rate required at the TA output, and the TA shall neither add nor drop null packets to maintain the precisely defined value. Except for the conversion of Precursor Packets to Transmitter Control Packets, the insertion of Dummy Data Bytes Channel data, and the insertion of Field-Rate Side Channel data, as provided herein, the TA shall make no alterations to the data stream received at its input. When in standard 8-VSB (A/53) mode of operation, should the data stream at its input not be precisely that required on its output, the TA may add or drop null packets, as necessary to maintain its output bit rate at the precisely defined value.

When no input is received by the Transmission Adapter from an upstream multiplexer, the TA is required to create a stream of MPEG-2 Transport Stream packets as described in Section 9.3.1.2 with the bit derived as defined above.

9.7 Transport Stream Output Release Timing

To enable the transmitter(s) in a system to emit AT Tick Alignment Points at precisely the times of AT Ticks, as required by A/153 Part 2 [5], Section 5.3.2.13.1 Data Field Sync, it is necessary for the TA to release (on its output) those AT Tick Alignment Points advanced (back-timed) from the occurrence of the corresponding AT Ticks. The timing advance is by the total amount of time required for the AT Tick Alignment Points to reach the antenna air interface(s) at the Reference Emission Time. That total amount of time matches the value of Maximum Delay. (In a transmitter network, any offsets from the reference emission time are accommodated by the individual transmitters.) Consequently, the TA shall release on its output the AT Tick Alignment Points advanced from AT Tick timing by the value of Maximum Delay.

9.8 M/H Encapsulation (MHE) Packet Identification

M/H Encapsulation (MHE) packets shall be identified with the PID value 0x1FF6. This value shall be the MHE Packet PID required by A/153 Part 2 [5], Section 5.3.2.6 Packet Formatter, to be inserted by the Packet Formatter defined therein. The MHE packets supplied to the input of the TA shall carry this PID value.

10. TRANSMITTER SYNCHRONIZATION

As shown in Figure 4.6 and described previously, the transmitter synchronization system comprises a Transmission Adapter (TA) at the source end of a studio-to-transmitter link (STL) combined with data processing subsystems at the transmitter(s) that are capable of responding to the synchronization signals inserted into a standard MPEG-2 Transport Stream by the TA. Characteristics other than the synchronization of transmitters synchronized according to this standard are defined in ATSC A/53 Part 2 [1] and A/153 Part 2 [5].

The Transmission Adapter is described in Section 9. The data processing subsystem at each transmitter, in addition to the normal processes of an 8-VSB (and optionally M/H) transmitter, performs the functions of responding to the Transmitter Control Packets (TCPs), carried in the TS and described in Sections 5 and 6, and to the Cadence Sync Points to which the TCPs point. The transmitter data processing subsystem substitutes for certain of the TCP data, in packets with the assigned PID and OM_type values, a duplicate of the fixed data pattern that was replaced by TCP data in the Transmission Adapter. This subsystem provides the necessary buffering of the trellis code states to support the slaving of the trellis coders at the appropriate times.

The channel coding processes of a typical 8-VSB M/H modulator are shown in block diagram form in Figure 10.1. Shown in that figure are only the portions of the subsystem necessary for ordinary data processing and ordinary signal processing and necessary to respond to the Transmitter Control Packets and to the Cadence Sync Points to which the TCPs point. Not shown are the mechanisms for extracting and applying the information from the TCP used for transmitter timing adjustment, for transmitter power adjustment, and for transmitter mode and identifier control. Not shown are the mechanisms for extracting and applying the information from the Field-Rate Side Channel for substitution of the reserved bits in the Data Field and Data Frame Synchronization data segments. Also not shown are the mechanisms for applying the information carried in the optional Dummy Data Bytes Channel for single transmitters.

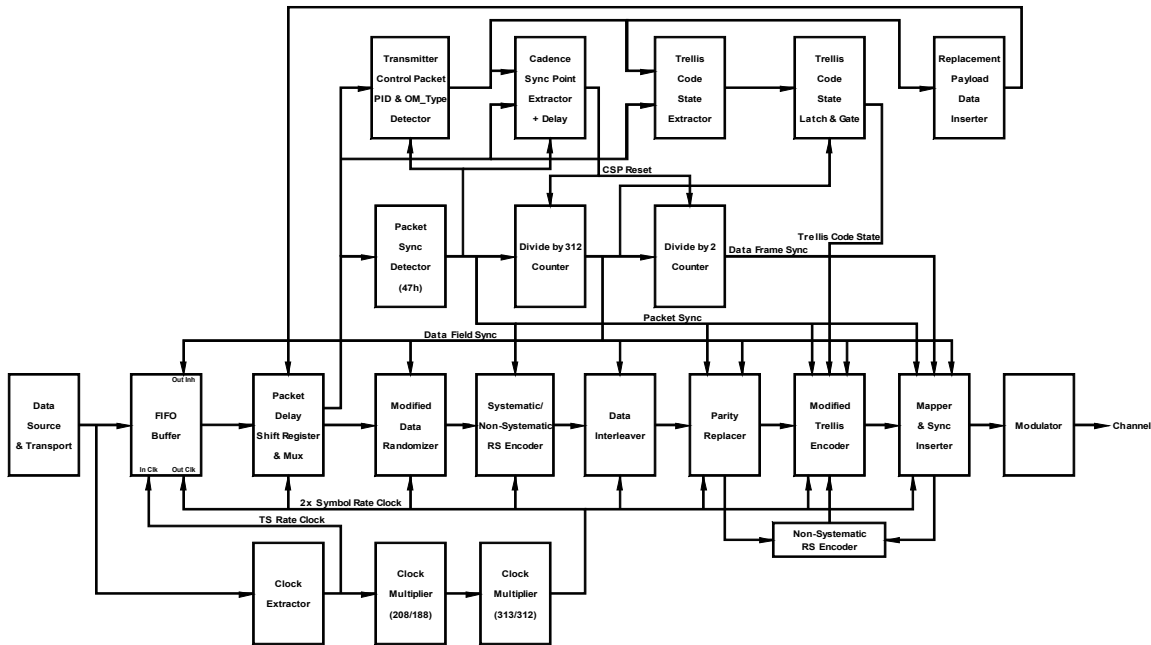

Figure 10.1 Synchronized 8-VSB M/H transmitter channel coding.

10.1 Standard Modulator Functions

Included in the synchronized modulator system of Figure 10.1 are all the standard functions of an 8-VSB M/H modulator as defined in ATSC A/153 Part 2 [5] as well as those necessary to

make such a modulator operate properly. The bottom three rows of Figure 10.1 represent the standard functionality, with the addition of one block required for the synchronization processes. The bulk of the added functions for the synchronization processes are contained in the top row of the diagram.

10.1.1 Data Processing

The basic data processing functions of an 8-VSB M/H modulator are carried out in the next-to-bottom row of Figure 10.1. They include a FIFO buffer to adjust the data rate to compensate for the insertion of Reed Solomon error correction coding and Data Field and Data Frame Sync data segments, the modified data randomizer, the systematic/non-systematic Reed Solomon encoder, the convolutional byte and symbol interleavers (shown as a block marked "data interleaver"), the parity replacer, the modified precoder and trellis encoders (shown as a block marked "modified trellis encoder"), and the mapper and sync inserter. Supporting these functions are the clock extractor and two clock multipliers (208/188 and 313/312) shown in the bottom row of the diagram. Also supporting the standard functionality are the three blocks of the third row from the bottom, namely, the packet sync detector, divide by 312 counter, and divide by 2 counter.

Without the additional functions included in the top row of the diagram and the added block in the next to bottom row, the modulator shown in Figure 10.1 would produce standard 8-VSB signals in the normal, unsynchronized way. The additional functions enable production of correctly formed and timed M/H signals and/or synchronized standard 8-VSB signals.

10.1.2 Signal Processing

Also included in Figure 10.1 is the normal signal processing portion of an 8-VSB modulator. It comprises part of the mapper plus the modulator shown on the right side of the next to bottom row of the diagram. Given the symbols from the modified trellis encoder, the mapper and modulator produce a complete modulated radio frequency signal that can be upconverted by the transmitter to the assigned channel of the digital television station.

10.2 Data Frame Cadence Synchronization

Two types of synchronization are required in modulators for M/H or Distributed Transmission. One is the time alignment of all the repetitive functions that are reset or are set to known states periodically in the modulation process. The second is the slaving of the states of the trellis encoders, which is described in Section 10.4. The repetitive processes that must be reset or set to known states are the modified data randomizer, the systematic/non-systematic Reed Solomon encoder, the convolutional byte interleaver, the symbol interleaver, and certain aspects of the precoder and trellis encoder operation. The time alignment of the necessary processes is enabled through periodic inclusion in the stream of Cadence Sync Points and pointers to them.

10.2.1 Cadence Sync Point Determination

Following the FIFO buffer at the left side of the next to bottom row is a packet delay shift register and multiplexer. It serves several purposes in the synchronization of both the repetitive processes and the stochastic processes. Fundamentally, it provides a fixed delay of 188 bytes (one MPEG-2 TS packet) and allows access to the contents of each packet prior to its entry into the normal data processing portion of the modulator. Effectively, it allows looking ahead into data that has not yet been processed and permits modifying the data before its entry into the normal data processing functions.

For synchronizing the repetitive functions in the modulator data processing subsystem, there is a detector that locates MPEG-2 packet sync words when they reach the output end of the

packet delay shift register. The packet sync detector is at the left end of the next to top row. It examines the stream for values of 0x47, which is the standard MPEG-2 packet sync word. When it detects a packet sync word exiting the packet delay shift register, it triggers the data segment sync function, time-aligning all the data processing functions that recycle at data segment periodicity. It also triggers the divide-by-312 counter and, through it, the divide-by-2 counter that together establish the timing of the Data Field and Data Frame Sync data segment insertion.

A second detector necessary for synchronizing transmitters is at the left end of the top row and is labeled as a Transmitter Control Packet PID & OM_Type detector. It examines the stream for presence in the packet delay shift register of a packet having specific identification characteristics; i.e., a packet having the PID value assigned to OM packets and having the OM Type value assigned to Transmitter Control Packets (TCPs) addressed to the group of transmitters of which its particular transmitter is a member.

When a TCP is identified as being correctly positioned in the packet delay shift register, the TCP detector triggers a cadence sync point extractor and delay that extracts from the TCP the value pointing to the next occurrence of a Cadence Sync Point (CSP). The extracted value is used to set a delay equal to the number of packets between the TCP and the next CSP. When that delay expires, it causes a reset of the divide-by-312 and divide-by-2 counters, establishing the location at which a Data Frame Sync data segment will be inserted, thereby starting the next Data Frame.

10.2.2 Data Frame Synchronization

When a Cadence Sync Point is located, several things happen. First, the packet sync detector is triggered to indicate the start of an MPEG-2 packet. This will result in triggering the data segment sync function as described in Section 10.2.1. All of the data processing functions that are normally time aligned with the packet sync and the Data Field sync also shall be aligned with the Cadence Sync Point, which coincides with the start of a data segment sync. The timing mechanism used to control insertion of Data Field Sync and Data Frame Sync data segments shall be controlled by the occurrence of the Cadence Sync Point (e.g., the two counters in the next to top row of Figure 10.1 are reset by occurrence of the Cadence Sync Point). A Data Frame Sync data segment (i.e., a Data Field Sync data segment with positive PN63) shall be inserted at the location in the MPEG-2 TS coincident with the CSP.

10.3 Transmitter Control Packet Payload Replacement

When the Transmission Adapter received the Precursor Packet from which it created the Transmitter Control Packet, the values of the words in the packet were known. Those words were then replaced in two stages with the information to be communicated by the Transmitter Control Packet. The first stage replaced certain words with data that are to be broadcast. The packet was then processed by the data processing model that exists in the TA to derive the trellis coder states to which the transmitters are to be slaved. The second stage replaced words that carry the trellis code state and Reed Solomon ECC data to the transmitters. At the transmitter, it is necessary to restore the known values of those words in the TCP that carry the trellis code state and Reed Solomon ECC data before they are data processed, so that the same trellis code states are obtained as at the Transmission Adapter.

The restoration process begins with a Transmitter Control Packet PID & OM Type detector. Each time a packet sync word is detected, the PID & OM Type detector is triggered to check for the occurrence of the PID and OM_type values assigned to the Transmitter Control Packet and to the group of transmitters of which the particular transmitter is a member. The detector looks into

the Packet Delay Shift Register at the appropriate location relative to where the packet sync word will be when detected.

When the TCP PID and applicable OM_type value are detected, the Trellis Code State Extractor to the right of the Cadence Sync Point extractor & delay will capture all of the needed information from the Transmitter Control Packet and store it in appropriate latches and registers. In Figure 10.1, only the Trellis Code State Latch and Gate is shown; similar storage devices are used for capturing the other information present in the packet.

10.3.1 Fixed Value Packet Payload

Once the information in the Transmitter Control Packet has been extracted from the packet and stored as necessary, certain of the information in the packet is replaced. At the right end of the top row is the Replacement Payload Data Inserter. Fundamentally, this block stores or creates a pattern of words having the value 0xFF, as defined in Section 9.2.2.1.1. When the Transmitter Control Packet is recognized and once the information in that packet has been extracted, the contents of the 3rd through the 14th and the 165th through 184th of the 184 payload bytes of the packet shall be replaced by the defined pattern of words (as, for example, by the Replacement Payload Data Inserter and the Packet Delay Shift Register and Multiplexer in Figure 10.1). In this way, the packet is restored to the state that it had after the first stage of processing in the TA—the state in which it was when it entered the data processing model of the TA.

10.3.2 Matches Pre-Processing Value

The payload inserted into the Transmitter Control Packet at the transmitter shall exactly match the values that were replaced in the second stage at the Transmission Adapter. The result will be that the signal that is processed by the transmitter modulator will be exactly the same as that which was processed by the data processing model in the Transmission Adapter.

10.3.3 Traverses Transmitter Modulator

The restored Transmitter Control Packets traverse the transmitter modulator and are transmitted in exactly the same way as are all the other packets. By this mechanism, when the trellis coder is synchronized with the trellis coder in the Transmission Adapter, after the first synchronization sequence and if there has been no interruption in the signal to the transmitter, there will be no modification of the values in the trellis coder. Instead the values at both ends of the transport system will match and will continue to run in lock step.

10.4 Trellis Code Slaving

In order to put the precoders and trellis encoders of all the transmitters in a network in the same states at the same time, it is necessary to “jam sync” them to the trellis coder model in the Transmission Adapter. By this mechanism, they will be set to matching states upon startup, and they will be maintained in matching states while running. Only upon occurrence of an error in the transport system to a transmitter or in the event of a change being made in the operational timing of a transmitter will it be necessary to resynchronize a transmitter during continued operation.

10.4.1 Trellis Code State Extraction

As previously described, when the PID and OM_type values assigned to the Transmitter Control Packet appear in the MPEG-2 Transport Stream, the Trellis Code State values contained in that packet shall be extracted and stored until needed (as, for example by the Trellis Code State Extractor and the Trellis Code State Latch and Gate in Figure 10.1).

10.4.2 Trellis Code State Slaving

Each time a Transmitter Control Packet is received from the transport system, the Trellis Code State data is stored in the Trellis Code State Latch and Gate through operation of the Transmitter Control Packet PID & OM Type Detector and the Trellis Code State Extractor. When the next Data Field Sync occurs, the Trellis Code State Latch is checked for the presence of current Trellis Code State data. If current trellis_code_state data is present, it shall be used to set the states of the precoder and trellis encoder storage elements during the Data Field Sync data segment. Then, when the first data segment following Data Field Sync starts, its trellis encoders will be in the same states as were those of the data processing model in the Transmission Adapter when it processed the same Transport Stream data.

The operation of an individual Synchronized Precoder and Trellis Encoder along with the Mapper is shown in Figure 10.2. The operation of the associated Synchronized Trellis Code Interleaver is shown in Figure 10.3. The processes described for Figures 6.1 and 6.2 are reversed in Figures 10.2 and 10.3, respectively, and the 36 bits of Trellis Code State data are inserted in 3-bit groups into the 12 related Precoders and Trellis Encoders when the Data Field Sync indicates the correct instant for doing so. The insertion takes place through control of the multiplexers on the inputs of the storage elements of each Precoder and Trellis Encoder. (Note that the designations of signals in Figure 10.2 match those of A/53 Part 2 [1], Figure 6.8.)

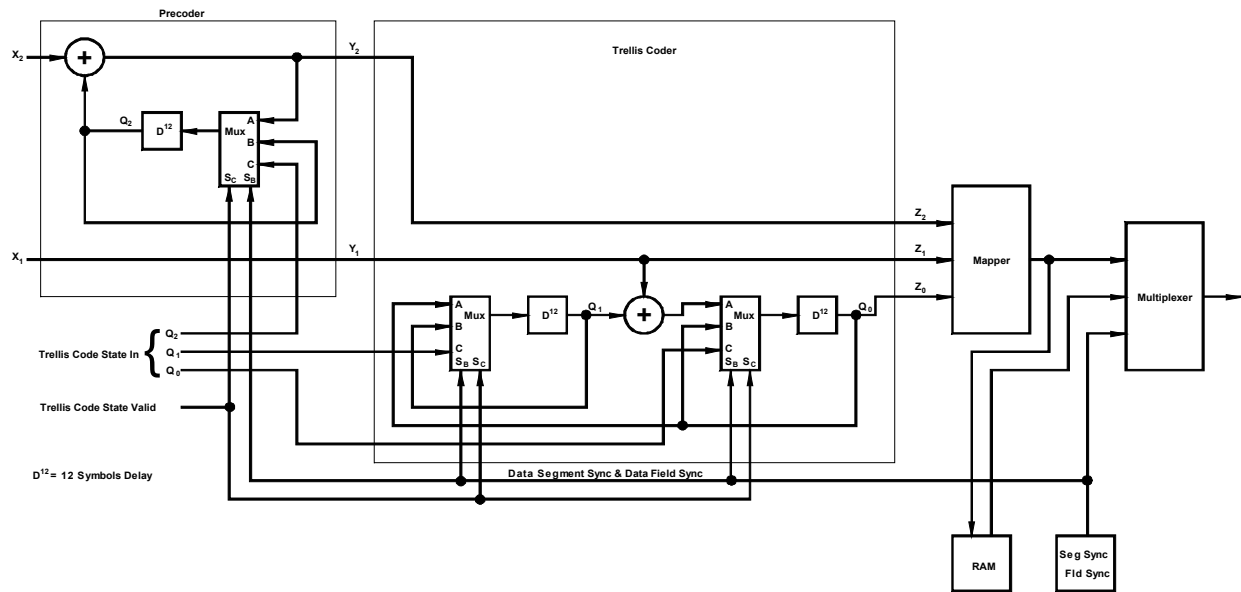

Figure 10.2 Synchronized precoder, Trellis coder, and mapper.

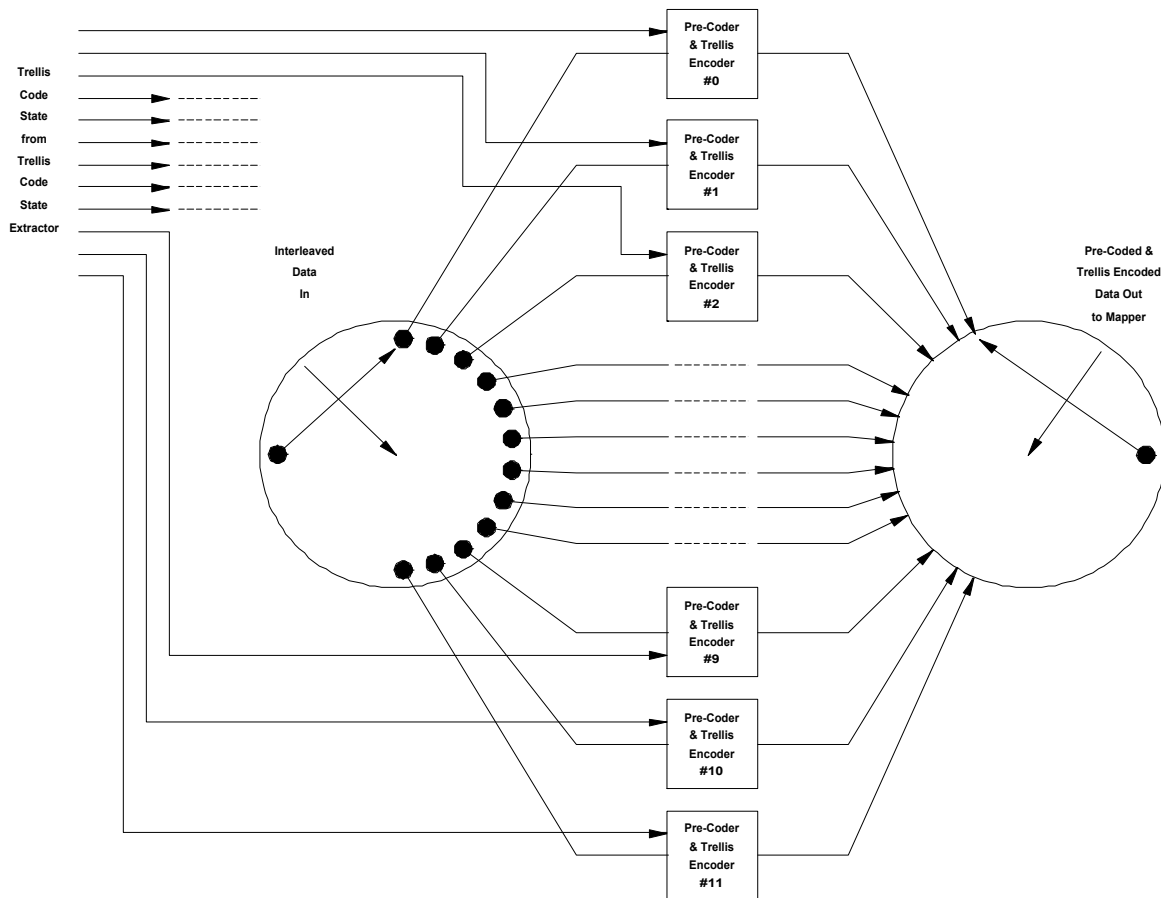

Figure 10.3 Synchronized Trellis code interleaver.

10.5 Formatted Data Restoration

Both of the methods for sending timing and other information from the Transmission Adapter to the transmitter(s), i.e., the Transmitter Control Packet or the Dummy Data Bytes Channel, alter portions of the data stream over the STL in ways that must be reversed at the transmitter(s) so that the defined data format for each mode of operation actually is emitted. Since both methods may be in use in a given system, or at least may appear together on the output of the TA in the system, to assure interoperability of equipment, it is necessary that all transmitters provide for restoration of the data with respect to both methods.

10.5.1 TCP Data Restoration

All transmitters, whether obtaining control information from TCPs or from the Dummy Data Bytes Channel, prior to their processing in the post processor, shall restore the values in the 3rd through the 14th and the 165th through 184th of the 184 payload bytes of each TCP with the pattern of words defined in Subsection 9.2.2.1.1 Fixed Values herein.

10.5.2 Dummy Data Bytes Channel Data Restoration

All transmitters, whether obtaining control information from the Dummy Data Bytes Channel or from TCPs, prior to their processing in the post processor, shall restore the values of the dummy

data bytes in the first five MHE packets of each M/H Group to the value specified in A/153 Part 2 [5], Subsection 5.3.2.5 Group Formatter.

10.6 Transmitter Frequency Control

Control of two specific transmitter frequencies is required to ensure successful operation of M/H systems and distributed transmission networks. The symbol clock frequency must be accurately controlled to enable maintenance of the required precision in M/H systems with respect to ATSC Time and to allow the output symbol stream to maintain stable relative time offsets between transmitters in a network. The RF frequency of the transmitted signal, as measured by the frequency of its pilot, must be accurately controlled to allow signals from several transmitters in a network to appear to receivers as echoes of one another.

10.6.1 Symbol Clock Frequency

The transmitter shall lock its symbol clock to the external precision reference frequency used throughout the network.

10.6.2 Pilot Frequency

As discussed previously, it is necessary to maintain all transmitters in a DTxN within a narrow frequency range so that there is little apparent Doppler shift created between them as perceived by receivers. Consequently, the pilot frequencies of all transmitters in a network shall be maintained within $\pm 1/2$ Hz of nominal frequency (i.e., ± 1 Hz of one another).

11. TRANSMITTER MODE CONTROL)

Provision is made in the Field-Rate Side Channel for carriage of Transmitter Mode Control bits that both control the operating mode of the transmitters and signal the transmitter operating mode to receivers. While not detailed in a diagram, the operation of the Mode Control bits at each transmitter is described in this Section. The extraction methods and application timing explained also apply to the Reserved bits that are transmitted in the Data Field Sync data segment, that are carried to the transmitters in the Field-Rate Side Channel, and that also may contribute to control of the mode of transmitter operation.

11.1 Mode Control Data Extraction

The `vsb_mode_data` bits and the `dfs_reserved_data` bits shall be extracted from the Field-Rate Side Channel by collecting the flag bits from the `transport_error_indicator` fields in the MPEG-2 TS packets carried in the data stream between two Cadence Sync Points. The 312 bits are divided between 184 data bits (including a 16-bit sync word at the start of the sequence, which can be used to locate both the beginning of the FRSC sequence and the position of the Cadence Sync Point in the data stream) and 128 Reed Solomon (RS) error correcting code (ECC) bits, as defined in Table 8.1. The data bits should be forward error corrected using the RS ECC bits. The error-corrected data collected shall be stored (e.g., in a register) until needed at the time of the next Data Field Sync or Data Frame Sync data segment.

11.2 VSB Mode Data Derivation

The `vsb_mode_data` bits to be transmitted in the Data Field Sync and Data Frame Sync data segments shall be extracted from the locations within the Field-Rate Side Channel defined in Table 8.1. They first shall be de-serialized and processed for error correction purposes as bytes,

together with the `dfs_reserved_data` and the other Field-Rate Side Channel data, then re-serialized into a stream of bits for inclusion in the Data Field Sync or Data Frame Sync data segments.

11.3 VSB Mode State Change Timing

When a change occurs in the `VSB_mode_data` bits as sent to the transmitters from the Transmission Adapter, the new `VSB_mode_data` bits shall be inserted into the next Data Field Sync or Data Frame Sync data segment to be transmitted after receipt of the new `VSB_mode_data` in the Transport Stream. The transmitter shall delay adoption of the new mode for one Data Field period. It shall transition to the new mode upon the occurrence of the segment sync of the next Data Field Sync or Data Frame Sync data segment following the Data Field Sync or Data Frame Sync data segment in which the updated `VSB_mode_data` bits were first transmitted.

11.4 DFS Reserved Data Derivation

The `dfs_reserved_data` bits to be transmitted in the Data Field Sync and Data Frame Sync data segments shall be extracted from the locations within the Field-Rate Side Channel defined in Table 8.1. They shall be de-serialized and processed for error correction purposes as bytes, together with the `VSB_mode_data` and the field-rate reserved data, then re-serialized into a stream of bits for inclusion in the Data Field Sync or Data Frame Sync data segments.

11.5 Transmitter Reserved Data Change Timing

When a change occurs in the `dfs_reserved_data` bits as sent to the transmitters from the Transmission Adapter, the new `dfs_reserved_data` bits shall be inserted into the next Data Field Sync or Data Frame Sync data segment to be transmitted after receipt of the new `dfs_reserved_data` in the Transport Stream. Should the `dfs_reserved_data` take on any meaning that affects the transmitter operation, the transmitter shall delay adoption of the new mode or other characteristics for one Data Field period. It shall transition to the new characteristics upon the occurrence of the segment sync of the next Data Field Sync or Data Frame Sync data segment following the Data Field Sync or Data Frame Sync data segment in which the updated `dfs_reserved_data` bits were first transmitted.

12. TRANSMITTER TIMING ADJUSTMENT

The timing information sent to single transmitters and sent collectively to all transmitters and individually to each transmitter in a network is described in Sections 6.2 and 6.4 and Figures 6.4a and 6.4b; in addition, optional timing information for single transmitters is described in Sections 7.2 and 7.3 and Figure 7.2. When a transmitter receives a Transmitter Control Packet, it shall calculate the time of emission for its signals based upon the timing information sent to it from the Transmission Adapter. Alternatively, when a transmitter receives timing information from the Dummy Data Bytes Channel, it may substitute that information for the timing information contained in the TCP to calculate the time of emission for its signals.

12.1 Time References and Emission Time Calculations

In order for each transmitter to calculate properly the time of emission for its signals, an appropriate time reference is required, and the emission time of a defined point in the transmitted symbol stream must be measured with respect to that time reference at a known system location. Ideally, the measurement location would be the antenna, and a fixed point in the signal would be measured as it was transmitted from the antenna. But the difficulties of sampling the signal there,

combined with the variation in system delay over the period of a data field inherent in the 8-VSB data processing scheme, make other system and signal points preferable. An indirect method therefore is used to determine and control the emission time.

The time delay from arrival of the Cadence Sync Point at the input of the conventional 8-VSB data processing subsystem until emission of the start of the corresponding Data Frame Sync data segment is used to determine the transmitter and antenna system delay (TAD, as described in Section 6.4.3). This provides a constant TAD value that is used in calculations to determine the actual emission time when a different point in the signal is used for the time measurements.

Emission time measurements occur at the input of the 8-VSB M/H data post-processing subsystem, which is defined as the input of the Modified Data Randomizer shown in Figure 10.1. The time of appearance at the measuring point of the Cadence Sync Point is measured against the 1-second clock ticks of the external precision time reference, and the result is the CSP Modulation time value. When the TAD value is added to the CSP Modulation time, the actual Emission time is obtained. The Transmitter Delay (Tx Delay) is adjusted automatically to cause the actual Emission time measured to match the desired Emission time as obtained from the sum of the Synchronization Time Stamp (STS), Maximum Delay (MD), and Offset Delay (OD) values applicable to the particular transmitter.

12.1.1 External Precision Time Reference

The external time reference shall be the one provided by the Global Positioning System (GPS) satellite navigation system and shall be determined with an accuracy of 50 ns peak-to-peak or better at all network locations.

12.1.1.1.1 One-Second Ticks

The one-second ticks of the external time reference shall be used to align the timing of the respective transmitters relative to one another and to the signals from the Transmission Adapter. In all cases, the leading edges of the one-second ticks shall be used as the time reference points.

12.2 CSP Modulation Time Alignment

As defined in Section 12.1, the time of CSP Modulation shall be set according to the information sent to all transmitters and to each individual transmitter, as defined in Sections 6.2 and 6.4 and Figures 6.4a and 6.4b (or, alternatively, as defined in Sections 7.2 and 7.3 and Figure 7.2). It should be noted that a change in the delay between the arrival of data in the Transport Stream (at the output of any FIFO buffer on the transmitter input) and its emission is disruptive to reception because the addition or deletion of symbols is required, thereby breaking the framing structure of the signal. This could occur, for example, when resynchronization of a transmitter is performed due to a disturbance in the STL.

12.2.1 STS Plus Max Delay Plus Offset Delay

As defined in Section 6.4 and Figure 6.4, the emission time shall be the sum of the Synchronization Time Stamp (STS) value plus the Maximum Delay (MD) value plus the individual transmitter Offset Delay. To maintain the appropriate emission time between CSPs, a transmitter should calculate the difference between CSP Arrival time and CSP Modulation time (i.e., the Tx Delay value) required to obtain its emission time after addition of its TAD value and should apply that value of Tx Delay to all data in the Transport Stream until the next CSP appears in the stream.

Determination of the TAD value requires calculating the time delay through the transmission system from the input to the conventional portion of the modulator's Modified Data Randomizer, through the upconversion and amplification stages, through the output filters and other RF equipment, through the transmission lines, and to the antenna. Equipment used to automatically adjust the Emission time shall have the capability to accept as an input a value representing the delay in the transmission system from a known point in the system beyond which delay can be measured or calculated for the remainder of the system through the antenna.

13. IDENTIFICATION CODE GENERATION AND TRANSMISSION

As described in Section 6.5, provision is made to individually identify transmitters through the use of an "RF watermark" so as to enable system monitoring and measurements, interference source determination, geolocation, and other applications. Such identification can be accomplished without requiring the shutting down of transmitters in order to determine which one or ones are contributing to the signals received at any given location. Moreover, the channel impulse response components of each transmitter received at a given location can be determined. This determination can allow in-service system adjustments of such characteristics as power levels and delay offsets.

As provided in the TCP data that is addressed to each transmitter, it is possible to set the insertion level of the buried spread spectrum (BSS) RF watermark signal in use at any time, including turning it off. The available insertion levels are chosen to allow operation from well below the normal noise floor of host 8-VSB transmitters up to levels that perhaps could cause some receivers to lose the ability to recover the signal. Obviously, the higher levels should only be used in out-of-service testing. The impacts of the various levels on typical receiver performance are documented in Table 6.3 and in the recommended practice that accompanies this standard (A/111 [8]).

The RF watermark used in both mandatory and optional applications to ATSC emissions shall be as described herein.

13.1 Code Generation

The buried spread spectrum RF watermark signal shall carry a Kasami code sequence that is transmitted repeatedly throughout the period when it is enabled in the emissions from the particular transmitter with which it is associated. The code shall be generated in a group of three shift registers having specified feedback arrangements and set to known values at specified times. The shift registers shall be clocked at the symbol rate of the host 8-VSB signal. Provision is made for modulation of the RF watermark signal by a slow speed serial data signal to permit separate data transmission for remote control and other purposes. Provision also is made for future enhancements in the code generation methods.

13.1.1 Multiple Shift Registers

The code transmitted by the BSS RF watermark signal shall be generated by a group of 3 shift registers having lengths, feedback paths and summing functions as defined in Figure 13.1. The shift registers also shall have inputs through which they can be preloaded upon the occurrence of an enabling pulse. The output of the set of shift registers shall be sent to the equivalent of a 2-VSB modulator for transmission with the 8-VSB host signal.

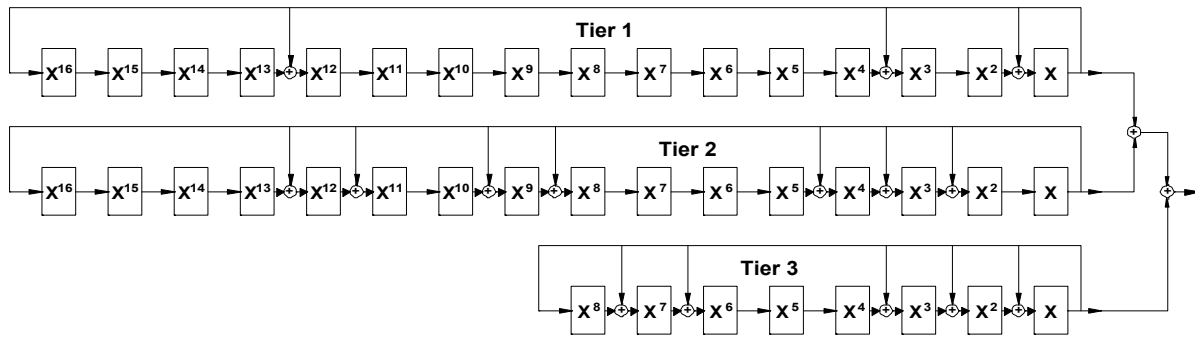

Figure 13.1 Identification code generator (Kasami sequences).

The generator polynomials used in the respective tiers of the sequence generator shall be:

$$\text{Tier 1 Generator Polynomial } G_{(16)} = X^{16} + X^{12} + X^3 + X + 1$$

$$\text{Tier 2 Generator Polynomial } G_{(16)} = X^{16} + X^{12} + X^{11} + X^9 + X^8 + X^4 + X^3 + X^2 + 1$$

$$\text{Tier 3 Generator Polynomial } G_{(8)} = X^8 + X^7 + X^6 + X^3 + X^2 + X + 1$$

13.1.2 Clock Rate and Phase

The clock applied to the shift registers shown in Figure 13.1 shall operate at the symbol clock rate of the host 8-VSB signal, as defined in ATSC A/53 Part 3 [2], Section 8.2. The clock rate, thus, will be approximately 10.76... MHz. The clock phase shall be set so that BSS symbols are generated in phase with the symbols of the host 8-VSB signal, as defined in Section 13.2.2.

13.1.3 Preloaded Values

The values preloaded into the shift registers of Figure 13.1 shall be those values sent in the TCP in the `tx_address`, and `network_identifier_pattern` fields. Each transmitter shall preload its individual `tx_address` data, and all transmitters within a network shall preload the same `network_identifier_pattern` data. In addition, one shift register shall be preloaded with a fixed value. The values shall be preloaded during Data Field Sync and Data Frame Sync data segments.

The shift register in Tier 1 of the Kasami code sequence generator of Figure 13.1 shall be preloaded with a value of 1 in the X stage and 0 in all the other stages. The twelve bits of the `tx_address` shall be preloaded into the X^{16} through X^5 stages of the Tier 2 shift register of the code sequence generator; the msb shall be preloaded into the X^{16} stage and the lsb into the X^5 stage. The four msb's of the `network_identifier_pattern` shall be preloaded into the X^4 through X stages of the Tier 2 shift register of the code sequence generator; the msb shall be preloaded into the X^4 stage and the fourth msb into the X stage. The eight lsb's of the `network_identifier_pattern` shall be preloaded into the X^8 through X stages of the Tier 3 shift register of the code sequence generator; the fifth msb shall be preloaded into the X^8 stage and the lsb into the X stage.

The preloading of the shift registers of the code sequence generator is summarized in Table 13.1. In the table, values denoted as "t" are the respective bits of the `tx_address` field, and those denoted as "n" are the respective bits of the `network_identifier_pattern` field.

Table 13.1 Code Sequence Generator Preloading

	Tier 1	Tier 2	Tier 3
X^{16}	0	t^{12}	—
X^{15}	0	t^{11}	—
X^{14}	0	t^{10}	—
X^{13}	0	t^9	—
X^{12}	0	t^8	—
X^{11}	0	t^7	—
X^{10}	0	t^6	—
X^9	0	t^5	—
X^8	0	t^4	n^8
X^7	0	t^3	n^7
X^6	0	t^2	n^6
X^5	0	t^1	n^5
X^4	0	n^{12}	n^4
X^3	0	n^{11}	n^3
X^2	0	n^{10}	n^2
X	1	n^9	n^1

13.1.4 Synchronization with Data Field Sync

The start of the transmitter identifier pattern (i.e., the generation of the first bit of the serial code to be output from the shift register arrangement of Figure 13.1 following preloading) shall occur at such a time as to cause the BSS symbol corresponding thereto to be emitted simultaneously with the first symbol of the data segment sync of the first data segment following Data Field Sync or Data Frame Sync of the host 8-VSB signal. By virtue of the length of a complete sequence, the code sequence shall occur three and a fraction times within a Data Field and shall be truncated during the fourth sequence in a Data Field upon reaching the data segment sync at the start of the next Data Field Sync or Data Frame Sync data segment.

13.1.5 Future Enhancements

Development of the codes to be used for transmitter and network identification and station signaling may continue after adoption of this standard. Designers of systems are advised to generate the transmitter and network identifier codes in programmable devices and to allow excess capacity for future growth of at least 50 percent more gates than are required to generate the code using the shift register scheme contained herein. Designers of systems also are advised that other truncation schemes might be adopted in the future; e.g., a method is possible in which each occurrence of the code sequence is truncated so that all four sequences within a data field are of equal length. Longer code sequences are also possible; e.g., a code sequence based upon shift registers of 18, 18, and 9 bits length would yield a code sequence slightly longer than a data field, requiring truncation of each sequence to make it fit within a data field.

13.2 Code Transmission

Transmission of the codes defined in Section 13.1 results in a signal at the bury ratio specified in Section 6.7.5. It produces an “RF watermark” signal having the features of 2-VSB transmission and the same emitted spectrum as the host 8-VSB signal.

13.2.1 2-VSB Signal

The buried spread spectrum (BSS) RF watermark signal shall be transmitted as a 2-VSB signal at an amplitude below the host 8-VSB signal as specified in Section 6.7.5. The characteristics of the 2-VSB signal, other than its amplitude and its framing structure, shall be identical to those of the Data Field Sync data segment as specified in A/53 Part 2 [1].

13.2.2 Symbol Synchronization

The symbols of the BSS RF watermark signal shall be synchronized with those of the host 8-VSB signal so as to be emitted at the same times. There shall be no framing structure applied to the BSS code signal. The BSS code signals shall continue during the data segment sync symbols of the host 8-VSB signal. The BSS code signals shall not be transmitted during the Data Field Sync data segments. Upon arrival at the time designated for the next pre-load of the code pattern seed for a transmitter, the then-current code sequence shall be truncated and the sequence started anew.

13.2.3 Emitted Spectrum

The emitted spectrum of the BSS RF watermark signal, taken by itself, shall conform to that depicted in Figures 6.4 and 6.17 of Part 2 of the ATSC A/53 Standard [1], with the exception that the ratio between the amplitudes of the BSS RF watermark and of the pilot shall reflect the bury ratio in use for the RF watermark signal.

13.3 Modulation by Serial Data Stream

As described in Section 6.5.2, provision is made for carriage of slow speed data by modulation of the watermark signal. All modulation and signaling is synchronous with the data structure of the host 8-VSB signal.

13.3.1 Modulation of RF Watermark Signal

Modulation of the RF watermark signal shall be by phase inversion of the code sequence associated with a transmitter. The phase inversions shall occur on a Kasami sequence-by-Kasami sequence basis. Each Kasami sequence shall represent one symbol of RF watermark modulation.

13.3.1.1 Phase Inversion of RF Watermark

Symbols of RF watermark modulation shall be created through inversion on a bit-by-bit basis of the output of the code sequence generator shown in Figure 13.1 for the entireties of individual Kasami sequences. A non-inverted code sequence symbol shall represent a zero or space bit of the modulating data, and an inverted code sequence symbol shall represent a one or mark bit of the modulating data.

13.3.1.2 Bit-Synchronous with Data Fields

Since the Kasami sequence repeats nearly four times per complete data field in the host 8-VSB data structure, four symbols of RF watermark modulation (corresponding to four bits of modulating data) shall be transmitted per host 8-VSB data field. RF watermark symbols and modulating data stream bits thus have lengths of approximately 6.05 ms, and the resulting baud rate is about 165.3 baud.

In coding the data to be carried by the RF watermark modulation, trade-offs are possible between data rate and robustness. For instance, symbols may be combined in pairs or in quads to gain 3 dB and 6 dB of robustness in exchange for 1/2 and 1/4 the data rate, respectively. Other

trade-offs also are possible using different coding schemes. Coding of the data carried by the RF watermark modulation is outside the scope of this standard but shall be explicitly permitted.