



ATSC Standard: Automatic Transmitter Power Control (ATPC) Data Return Link (DRL) Standard

Document A/82, 11 February 2008

Advanced Television Systems Committee, Inc.
1750 K Street, N.W., Suite 1200
Washington, D.C. 20006

The Advanced Television Systems Committee, Inc., is an international, non-profit organization developing voluntary standards for digital television. The ATSC member organizations represent the broadcast, broadcast equipment, motion picture, consumer electronics, computer, cable, satellite, and semiconductor industries.

Specifically, ATSC is working to coordinate television standards among different communications media focusing on digital television, interactive systems, and broadband multimedia communications. ATSC is also developing digital television implementation strategies and presenting educational seminars on the ATSC standards.

ATSC was formed in 1982 by the member organizations of the Joint Committee on InterSociety Coordination (JCIC): the Electronic Industries Association (EIA), the Institute of Electrical and Electronic Engineers (IEEE), the National Association of Broadcasters (NAB), the National Cable Television Association (NCTA), and the Society of Motion Picture and Television Engineers (SMPTE). Currently, there are approximately 140 members representing the broadcast, broadcast equipment, motion picture, consumer electronics, computer, cable, satellite, and semiconductor industries.

ATSC Digital TV Standards include digital high definition television (HDTV), standard definition television (SDTV), data broadcasting, multichannel surround-sound audio, and satellite direct-to-home broadcasting. Contact information is given below.

| | |
|-----------------|--|
| Mailing address | Advanced Television Systems Committee, Inc. 1750 K Street, N.W., Suite 1200 Washington, D.C. 20006 |
| Telephone | 202-872-9160 (voice) 202-872-9161 (fax) |
| Web site | http://www.atsc.org |
| E-mail | standards@atsc.org |

The revision history of this document is given below.

A/82 Revision History

| | |
|---------------|------------------|
| A/82 approved | 11 February 2008 |
|---------------|------------------|

Table of Contents

| | |
|---|-----------|
| 1. INTRODUCTION | 7 |
| 1.1 Scope | 7 |
| 1.2 Document Structure | 7 |
| 1.3 Data Return Link Background | 8 |
| 1.3.1 The ATPC Application | 8 |
| 2. REFERENCES | 9 |
| 2.1 Normative References | 9 |
| 2.2 Informative References | 9 |
| 3. DEFINITION OF TERMS | 10 |
| 3.1 Compliance Notation | 10 |
| 3.2 Treatment of Syntactic Elements | 10 |
| 3.3 Acronyms and Abbreviation | 10 |
| 3.4 Terms | 11 |
| 4. DRL SYSTEM OVERVIEW (INFORMATIVE) | 11 |
| 4.1 Operating Environment | 12 |
| 4.1.1 General Operation | 12 |
| 4.2 DRL Band Plan Definition and Channel Assignments | 13 |
| 4.3 DRL System Control Metrics | 13 |
| 4.3.1 Reliability Predictions and Requirements | 14 |
| 4.3.2 Antenna Requirements | 14 |
| 4.4 DRL Coverage Area | 15 |
| 4.4.1 Microwave Link Budget Analysis | 15 |
| 4.5 RF Watermark Identification | 16 |
| 4.5.1 Insertion of the Sync Sequence | 18 |
| 4.5.2 Direct Use of the Watermark Signal by COFDM ENG Transmitter | 19 |
| 4.6 DRL Modulation Method | 19 |
| 4.7 Network Interface Considerations | 20 |
| 5. DRL TRANSMISSION SYSTEM (NORMATIVE) | 20 |
| 5.1 DRL Transmitter Architecture | 21 |
| 5.1.1 General Operating Modes | 22 |
| 5.2 Microwave/RF Operating Parameters | 22 |
| 5.2.1 Transmitter Power Output | 22 |
| 5.2.2 EIRP Limitation | 22 |
| 5.2.3 Modulation Method | 23 |
| 5.2.4 Frequency Stability | 23 |
| 5.2.5 Channel Tuning Range Requirements | 23 |
| 5.2.6 Occupied Bandwidth | 23 |
| 5.2.6.1 Adjacent Channel Leakage Ratio | 24 |
| 5.2.7 Emission Designator | 24 |
| 5.2.8 Antenna Output Interface | 24 |
| 5.2.9 Transmitting Antenna | 24 |
| 5.3 RF Watermark | 24 |

| | |
|--|-----------|
| 5.3.1 RF Watermark Parameters | 24 |
| 5.3.2 Transmitter Identification | 25 |
| 5.4 Digital ENG Transmitter Control Metrics | 25 |
| 5.4.1 Transport Stream Structure | 25 |
| 5.4.1.1 APC Control Metric Parameter | 26 |
| 5.4.1.1.1 modulation_index = 0/1 | 27 |
| 5.4.1.1.2 modulation_index = 2 | 27 |
| 5.4.1.1.3 modulation_index = 3 | 28 |
| 5.4.1.1.4 modulation_index = 4 | 29 |
| 5.4.1.2 Modulation Command Parameter | 29 |
| 5.4.1.2.1 modulation_command = 0 | 30 |
| 5.4.1.2.2 modulation_command = 1 | 30 |
| 5.4.1.2.3 modulation_command = 2 | 31 |
| 5.4.1.2.4 modulation_command = 3 | 31 |
| 5.4.1.2.5 modulation_command = 4 | 32 |
| 5.4.1.3 Watermark Return Parameter | 32 |
| 5.4.1.4 Beacon Operational Mode | 32 |
| 5.5 Data Interfaces | 33 |
| 5.5.1 Control Interface | 34 |
| 5.5.2 Network Interface | 34 |
| 6. DRL RECEIVER SYSTEM (INFORMATIVE) | 34 |
| 6.1 Basic Functionality Overview | 34 |
| 6.1.1 Receiver Block Diagram | 35 |
| 6.1.2 Basic Receiver Functions | 35 |
| 6.2 Microwave/RF | 35 |
| 6.2.1 Channel Tuning Range | 35 |
| 6.2.2 Frequency Stability | 35 |
| 6.2.3 Adjacent Channel Rejection Ratio | 35 |
| 6.3 Physical Input/Output | 37 |
| 6.3.1 Antenna Input Interface | 37 |
| 6.3.2 Control Interface | 37 |
| 6.3.3 Network Interface | 37 |
| 6.3.4 Control/Monitor Interface | 37 |
| 7. DRL SYSTEM IMPLEMENTATION CONSIDERATIONS (INFORMATIVE) | 37 |
| 7.1 Coordination Requirements for Multi-Station Central Receiver Sites | 37 |
| 7.2 Emission Mask Measurement | 38 |
| 7.3 Analysis of Channel 1/7 Interference with the DRL Receiver | 39 |
| 7.3.1 Possible Solutions | 41 |
| Annex A: D-ENG Feeder Link Identification Watermark (Normative) | 43 |
| A1. OVERVIEW | 43 |
| A2. TRANSMITTER IDENTIFICATION | 43 |
| A3. D-ENG WATERMARK | 43 |
| A4. IMPLEMENTATION CONSIDERATIONS (INFORMATIVE) | 44 |

Index of Tables

| | |
|---|----|
| Table 4.1 DRL System Link Budget Values | 16 |
| Table 4.2 DRL System Modulation and Channel Coding | 19 |
| Table 5.1 DRL Channels | 22 |
| Table 5.2 Transport Packet Structure | 25 |
| Table 5.3 Packet Identifier | 26 |
| Table 5.4 APC Control Metric | 26 |
| Table 5.5 Modulation Indicator Enumeration | 27 |
| Table 5.6 Undetermined/FM Modulation (modulation_index = 0/1) | 27 |
| Table 5.7 COFDM-DVB-T (modulation_index = 2) | 27 |
| Table 5.8 VSB ATSC (modulation_index = 3) | 28 |
| Table 5.9 Single Carrier Modulation (modulation_index = 4) | 29 |
| Table 5.10 Modulation Command Enumeration | 30 |
| Table 5.11 Generic (modulation_command = 0) | 30 |
| Table 5.12 FM (modulation_command = 1) | 30 |
| Table 5.13 COFDM-DVB-T (modulation_command = 2) | 31 |
| Table 5.14 VSB-ATSC (modulation_command = 3) | 31 |
| Table 5.15 SCM (modulation_command = 4) | 32 |
| Table 5.16 Watermark Return Parameters | 32 |
| Table 5.17 Control Interface Pin-Out | 34 |
| Table 7.1 Analysis of ENG Interference into DRL Receiver | 40 |
| Table A3.1 Kasami Sequences as a Function of Operating Mode | 44 |

Index of Figures

| | |
|--|----|
| Figure 4.1 BAS channel plan (frequencies shown in MHz). | 13 |
| Figure 4.2 ENG-RO site without ATPC via DRL. | 14 |
| Figure 4.3 ENG-RO site using ATPC via DRL. | 15 |
| Figure 4.4 DRL RF watermark injection level. | 17 |
| Figure 4.5 Code generator for 10-bit Kasami sequences. | 17 |
| Figure 4.6 Eye diagram before and after insertion of -18 dB transmitter ID sequence. | 18 |
| Figure 4.7 Watermark synchronization sequence. | 19 |
| Figure 4.8 The encoder for the convolutional code of rate $1/2$. | 20 |
| Figure 4.9 The constellation of QPSK modulation. | 21 |
| Figure 5.1 Block diagram of a DRL transmitter. | 21 |
| Figure 5.2 DRL channel emission spectrum; frequency vs. amplitude in dB. | 23 |
| Figure 5.3 Beacon Mode operation (microwave transmitter interface). | 33 |
| Figure 6.1 Basic block Diagram of a DRL receiver. | 36 |
| Figure 7.1 Typical ENG spectrum vs. FCC mask. | 39 |
| Figure 7.2 DRL receiver in-line with an ENG transmitter (worst case). | 41 |
| Figure 7.3 DRL RX offset below interfering ENG transmitting antenna. | 41 |
| Figure A3.1 Structure of the RF watermark within the DVB frame. | 43 |
| Figure A3.2 Kasami sequence generator (16-bit). | 44 |

ATSC Standard:

Automatic Transmitter Power Control (ATPC) Data Return Link (DRL) Standard

1. INTRODUCTION

This Standard was prepared by the Advanced Television Systems Committee (ATSC) Technology and Standards Group (TSG) Specialist Group on Digital ENG (TSG/S3). The document was approved by TSG on 7 November 2007 as a Proposed Standard, and by the ATSC membership on 11 February 2008 as an ATSC Standard.

1.1 Scope

This document provides the necessary specifications to construct a Data Return Link (DRL) system for automatic transmitter control (ATPC) applications. The emitted signals of transmitters operated in accordance with this document comply fully with the specifications outlined in Section 5. This document further specifies the mechanisms necessary for basic identification and power control of TV Broadcast Auxiliary Service (BAS) transmitters, in either an automatic or manual mode. The initial, and default, operating mode is known as the “Beacon Mode.” An optional, lower-power operating mode, known as the “Transport Mode,” may be used if the RF environment permits. Both modes include the necessary mechanisms to permit the carriage of specialized private data (e.g., camera control information and operator communications) that is applicable to remote field production.

This document defines transmission parameters only. Receiver implementations are beyond the scope of this specification.

1.2 Document Structure

The document is organized as follows:

- Section 1 – Provides this general introduction.
- Section 2 – Lists references and applicable documents.
- Section 3 – Provides a definition of terms, acronyms, and abbreviations for this document.
- Section 4 – Provides detailed information on the background and use of DRL systems.
(Informative)
- Section 5 – Specifies the transmitter transmission parameters for a DRL system.
(Normative)
- Section 6 – Provides receiver implementation information for a DRL system.
(Informative)
- Section 7 – Provides implementation guidance for construction of a DRL system
(Informative)

The sections listed above fully specify the Beacon Mode of the DRL system and provide the necessary links to the optional Transport Mode, which may be developed as a future extension of this specification.

1.3 Data Return Link Background

In the 10 November 2003 ET Docket 95-18 *Third Report and Order*, the United States Federal Communications Commission (FCC) adopted a suggestion of the Society of Broadcast Engineers (SBE) to create two 500-kHz wide data return¹ link (DRL) bands [4] at the lower and upper edges of the re-farmed 2,025–2,110 MHz TV Broadcast Auxiliary Service band [5]. A total of forty 25-kHz wide DRL channels were created, twenty in the lower DRL band, and twenty in the upper DRL band. These channels may be used to support important new applications relating to remote station operations.

The DRL channels permit a “feedback” or “return” link to be established from an ENG receive only (ENG-RO) site to an originating TV pickup station (commonly referred to as an ENG truck). This link allows automatic transmitter power control (ATPC) by ENG trucks, and more efficient usage of the seven 2 GHz TV BAS channels. ATPC is the application addressed by this standard.

Complimentary applications relating to remote production, such as camera control and operator communications, are also envisioned but are not included in this standard². It is important to note that “return” as used above is not limited to signals going from the receive site to the remote location. The data might also go the other way. As such, the channels could also be used for two-way data communications, camera intercom, control functions, and so on.

1.3.1 The ATPC Application

Because the ET 95-18 *Report and Order* did not adopt technical or operating rules for DRL channels, there was, accordingly, a need for the appropriate technical specifications to be developed. Elements addressed by this standard relating to ATPC include:

- Basic system parameters; e.g., modulation type, occupied bandwidth, radiated power, emission mask, and frequency stability.
- Protocols and signaling. Established communications protocols are used where possible.
- Operational issues; e.g., data transmitted, priority of messages, and station identification.

With proper implementation of a DRL ATPC system, only the necessary amount of ENG output power is utilized to achieve reliable transmission. This facilitates more efficient use of the current ENG spectrum by minimizing the likelihood of interference among users in a given market or geographic location. It should be noted that any location may become frequency-congested in response to a major news or sporting event.

Note: Throughout this document the term “ENG” is used. It is important to emphasize that the applications for DRL systems extend beyond strictly news events. Related and complimentary applications include coverage of sporting events (e.g., golf tournaments and motor races) and remote field production (e.g., parades and political conventions).

1. In this context, the “return” path is from an ENG receive only (ENG-RO) site to a TV pickup station (ENG truck) originating an incoming ENG feed. Thus, the “return” path is not from an ENG truck in the field to an ENG-RO site or TV station studio, but from an ENG-RO site back to the ENG truck. The purpose is to let the ENG truck operator know that a successful link has been established with a particular ENG-RO site, and to let the ENG truck operator know the strength of that incoming digital ENG signal. This allows (but does not require) automatic transmitter power control (ATPC) by the originating ENG truck.
2. Such applications may be addressed in future extensions of this standard or through development of new standards.

2. REFERENCES

At the time of publication, the editions indicated below were valid. All standards are subject to revision, and parties to agreement based on this standard are encouraged to investigate the possibility of applying the most recent editions of the documents listed below.

2.1 Normative References

The following documents contain provisions which, through reference in this text, constitute provisions of this standard.

- [1] IEEE: IEEE/ASTM SI 10-2002, “Use of the International Systems of Units (SI): The Modern Metric System”, Institute of Electrical and Electronics Engineers, New York, N.Y.
- [2] TIA: TIA-422-B, “Electrical Characteristics of Balanced Voltage Digital Interface Circuits,” Telecommunications Industries Association, Arlington, VA, 1 May 1994.
- [3] ATSC: “Synchronization Standard for Distributed Transmission,” Doc. A/110A, Advanced Television Systems Committee, Washington, D.C., 19 July 2005.

2.2 Informative References

- [4] FCC: ET Docket 95-18, Third Report and Order, Federal Communications Commission, Washington, D.C., November 2003.
- [5] Title 47 Code of Federal Regulations, Part 74, Subpart F, “Experimental Radio, Auxiliary, Special Broadcast and Other Program Distribution Services,” Federal Communications Commission, Washington, D.C.
- [6] ATSC: “Design Of Synchronized Multiple Transmitter Networks,” Doc. A/111, Advanced Television Systems Committee, Washington, D.C., 3 September 2004.
- [7] IEEE: IEEE 802.3, “LAN/MAN CSMA/CD Access Method,” Institute of Electrical and Electronics Engineers, New York, NY.
- [8] TIA: TIA-568-B.2.5, “Commercial Building Telecommunications Cabling Standard – Part 2: Balanced Twisted-Pair Cabling Components,” Telecommunications Industry Association, January 2003.
- [9] ISO: ISO/IEC IS 13818-1:2000 (E), International Standard, Information technology – Generic coding of moving pictures and associated audio information: systems.
- [10] TIA: TIA-102.CAAA-B, “Digital C4FM/CQPSK Transceiver Measurement Methods,” Telecommunications Industries Association, Arlington, VA.
- [11] Title 47 Code of Federal Regulations, Part 74, Subpart F, Section 74.637, “Emissions and Emission Limitations,” Federal Communications Commission, Washington, D.C.
- [12] ATSC: “ATSC Digital Television Standard, Part 3 – Service Multiplex and Transport Subsystem Characteristics,” Doc. A/53, Part 3:2007, Advanced Television Systems Committee, Washington, D.C., 3 January 2007.
- [13] ETSI: ETSI EN 300 744 V1.4.1 (2001-01), “European Standard (Telecommunications series) Digital Video Broadcasting (DVB); Framing structure, channel coding and modulation for digital terrestrial television.”

3. DEFINITION OF TERMS

With respect to definition of terms, abbreviations, and units, the practice of the Institute of Electrical and Electronics Engineers (IEEE) as outlined in the Institute's published standards [1] shall be used. Where an abbreviation is not covered by IEEE practice, or industry practice differs from IEEE practice, then the abbreviation in question will be described in Sections 3.3 and 3.4 of this document.

3.1 Compliance Notation

As used in this document, "shall" or "will" denotes a mandatory provision of the standard. "Should" denotes a provision that is recommended but not mandatory. "May" denotes a feature whose presence does not preclude compliance, which may or may not be present at the option of the implementer.

3.2 Treatment of Syntactic Elements

This document contains symbolic references to syntactic elements used in the audio, video, and transport coding subsystems. These references are typographically distinguished by the use of a different font (e.g., *restricted*), may contain the underscore character (e.g., `sequence_end_code`) and may consist of character strings that are not English words (e.g., `dynrng`).

3.3 Acronyms and Abbreviation

The following acronyms and abbreviations are used within this specification.

| | |
|--------|---|
| ACRR | adjacent channel rejection ratio |
| ACIR | adjacent channel interference ratio |
| ACLR | adjacent channel leakage ratio |
| ATC | ancillary terrestrial component (MSS terrestrial base stations) |
| ATPC | automatic transmitter power controls |
| ATSC | Advanced Television Systems Committee |
| BAS | Broadcast Auxiliary Services (Part 74 of the FCC Rules) |
| BER | bit error rate |
| BFO | brute force overload |
| BPSK | binary phase-shift keying |
| BSS | buried spread spectrum |
| C/N | carrier to noise |
| CMRS | commercial mobile radio services (cellular, SMR and PCS) |
| COFDM | coded orthogonal frequency division multiplexing |
| CRC | cyclic redundancy check |
| DENG | digital electronic news gathering |
| DRL | data return link |
| EIRP | equivalent isotropic radiated power |
| ENG | electronic news gathering (in the context of this document, "ENG" includes electronic field production) |
| ENG-RO | ENG receive-only site (also known as "central" receive site) |
| FEC | forward error correction |
| FSPL | free-space power loss |
| FSK | frequency-shift keying |
| GMSK | Gaussian minimum shift keying |
| LOS | line of sight |
| LQ | link quality |

| | |
|--------|---|
| MER | modulation error ratio |
| MSK | minimum shift keying |
| MSS | mobile satellite service |
| MWCS | Miscellaneous Wireless Communications Services |
| OOBE | out of band emissions (spurious signals) |
| OQPSK | offset quadrature phase-shift keying |
| PCS | personal communications services |
| PPM | parts per million |
| PSK | phase-shift keying |
| QPSK | quadrature phase-shift keying |
| RCL | receive carrier level |
| rpchof | remainder polynomial coefficients, highest order first |
| RF | radio frequency |
| SCM | single carrier modulation) |
| simsbf | signed integer, most significant bit first |
| S/N | signal to noise ratio |
| SMR | specialized mobile radio |
| TPO | transmitter power output |
| TV BAS | Television Broadcast Auxiliary Service rules (Part 74, subpart f, of the FCC Rules) |
| TxD | transmitter identification signal |
| uimsbf | unsigned integer, most significant bit first |

3.4 Terms

Beacon Mode – The initial (default) operating mode of the DRL system in which the communication link is established and the general operating parameters are set.

buried spread spectrum – A technique permitting carriage of data in the same spectrum with, but without interference to, another signal by transmitting that data at a much reduced level relative to the primary signal and using coding techniques to permit its recovery with adequate signal-to-noise ratio.

modulation error ratio – A measure of the constellation cluster variance due to any impairment imperfections measured relative to the ideal constellation point locations.

packet – A collection of data sent as a unit, including a header to identify and indicate other properties of the data, and a payload comprising the data actually to be sent, either having a fixed, known length or having means to indicate either its length or its end.

RF watermark – A buried spread spectrum (BSS) signal carrying codes used for the purpose of identification of the host signal with which it is associated and for carrying a small amount of low speed data.

Transport Mode – An optional, lower-power operating mode of the DRL system that may be used if the RF environment permits. Note that the initial, and default, operating mode of the DRL system is the *Beacon Mode*.

4. DRL SYSTEM OVERVIEW (INFORMATIVE)

The DRL system is intended to serve as a 2 GHz microwave return link from the ENG central receive site to the ENG truck in the field. The link is used to supply return *power control* metrics and other applicable information vital for remote ENG communications. The DRL system is also

intended to facilitate various applications useful for remote field production, which may be specified in a future revision of this document or left to individual users and/or vendors to develop.

The return power control metrics are used to control the 2 GHz ENG transmitter output power for a digital ENG application. The power control capabilities are used to improve the spectrum efficiency with which ENG transmissions take place. The DRL return link regulates the amount of output power with which ENG transmissions can occur; only the necessary amount of ENG output power is utilized to achieve reliable transmission. This facilitates more efficient utilization of the current ENG spectrum by minimizing the likelihood of interference among users in a given market or geographic location.

For the ATPC application, the DRL system consists of a 2 GHz DRL microwave transmitter and antenna situated high atop the central receive site or any other microwave-friendly environment. The microwave transmitter is supplied DC and control information via a specified cable interface. A 2 GHz DRL receiver is utilized at the ENG truck, which interfaces with the ENG transmitter.

4.1 Operating Environment

The DRL channels provide forty 25-kHz wide channels in the same frequency band as the seven 12-MHz wide 2 GHz TV BAS channels. The intended use is to provide a communications path from an ENG-RO site to an ENG truck (or other ENG platform). It should be noted that the incoming ENG feed already provides a communications path from an ENG truck to an ENG central receive site.

A secondary purpose is to provide 0.5 MHz wide guard bands, at the lower and upper edges of the 2,025–2,110 MHz TV BAS band to minimize the interference threat from adjacent-band Commercial Mobile Wireless Services (CMRS) and Miscellaneous Wireless Communications Services (MWCS) base stations with an equivalent isotropic radiated power (EIRP) of up to 1,600 watts.

4.1.1 General Operation

The DRL system conveys two basic signals: the *RF watermark* and the *Beacon/Transport Mode* data. The RF watermark signal is used to uniquely identify the DRL transmitter and to serve as a homing beacon. It is transmitted continuously as a buried spread spectrum signal. The Beacon Mode is the initial (default) operating mode of the system, providing data on the received carrier level (RCL) of the incoming feed and other parameters. Once the DRL link has been established, the Transport Mode, a lower-power optional mode, may be used if the RF environment permits.

Auxiliary private data may be conveyed in the Beacon/Transport Mode to accommodate the case where an ENG truck has line-of-sight to an ENG-RO site, but not to the station's main DTV transmitting antenna. For this situation, the ancillary data portion of the 8-VSB broadcast signal might not be available for communication from the DTV station to an ENG truck. However, a DRL channel, originating from an ENG-RO site that does have line-of-sight to the ENG truck could then be used for data transfer purposes, albeit with a much smaller data throughput than that available using the station's DTV signal.

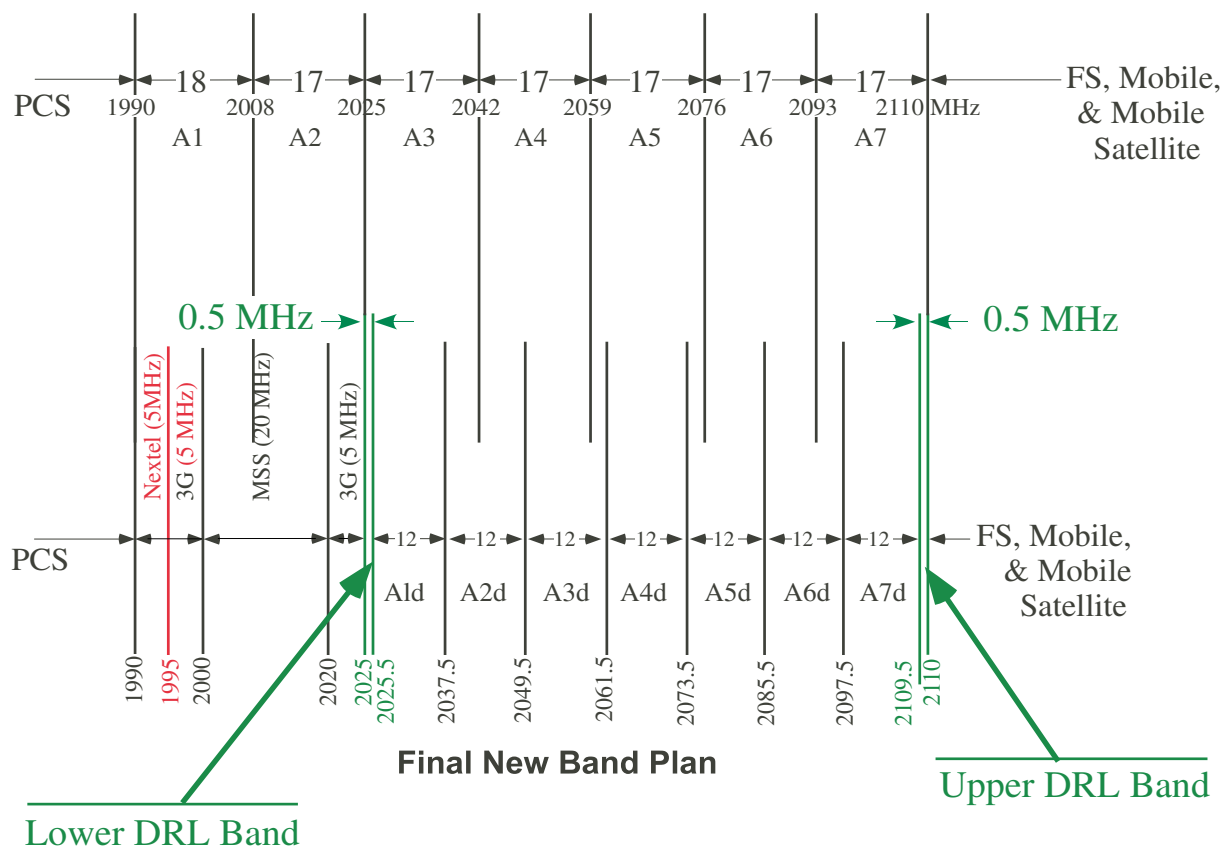

Figure 4.1 BAS channel plan (frequencies shown in MHz).

4.2 DRL Band Plan Definition and Channel Assignments

Figure 4.1 shows the DRL channel frequencies across the 1 MHz of available DRL spectrum, 500 kHz in the DRL lower band and 500 kHz in the DRL upper band. Channels 1 – 20 are within the DRL lower band and channels 21 – 40 are within the DRL upper band.

The DRL channel assignment is dependent upon and varies with each individual market segment. A DRL “home channel” plan may be developed for individual markets. A scanning system may also be used that automatically selects the next available cross-band³ second-adjacent DRL channel in response to an incoming ENG feed.

4.3 DRL System Control Metrics

If an ENG truck (or other ENG platform) is equipped with a DRL receiving system, the DRL receiver will typically interface to the ENG transmitter to allow for ATPC by the ENG truck transmitter. Such ATPC is especially important in congested ENG markets, where split-channel operation using COFDM signals with 6-MHz wide pedestals are most likely to be used, in order to increase the effective channel capacity from seven to fourteen channels.

3. In this context, *cross-band* means that an incoming ENG feed on Channels A1 through A3 uses one of the twenty upper DRL channels, and an incoming ENG feed on Channels A5 through A7 uses one of the twenty lower DRL channels. An incoming feed on Channel A4 can use a DRL channel from either the lower or upper DRL bands.

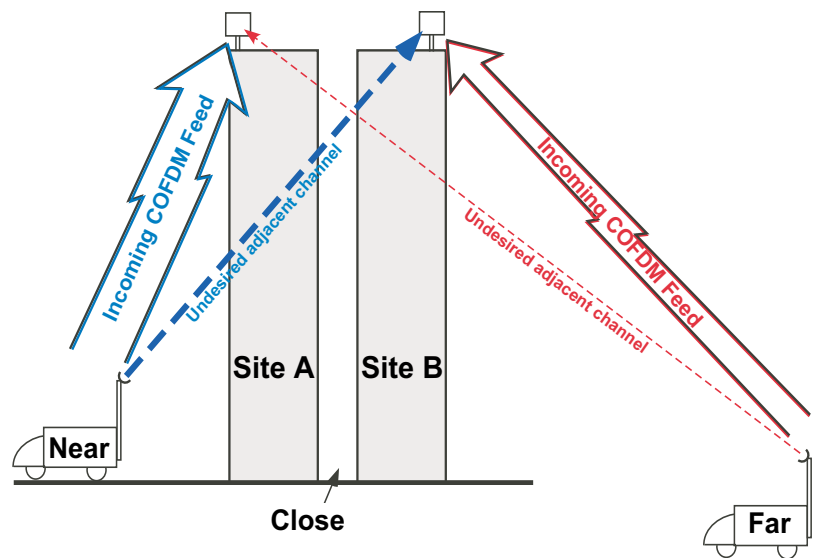

Figure 4.2 ENG-RO site without ATPC via DRL.

For split-channel operation, it is particularly important that the desired-to-undesired (D/U) signal ratio between the two incoming signals be close to zero dB. If one originating ENG truck is close to an ENG-RO site, but the other truck is not, the DRL signal can be used to reduce the transmitter power of the close-in truck so as to match the RCL of the COFDM signal from the distant ENG truck.

This balancing of RCLs applies to both a single ENG-RO site, where two split-channel COFDM signals are attempting to simultaneously feed a single site, and to separate but nearby ENG-RO sites of two different TV stations. In congested TV markets, it is to the mutual advantage of even competing TV stations to cooperate on the technical operations of their respective ENG operations, especially when adjacent home-channel frequency assignments are involved. Figures 4.2 and 4.3 demonstrate this concept.

4.3.1 Reliability Predictions and Requirements

If ATPC is implemented, it should be fail-safe in nature; that is, if for any reason the DRL signal is lost, the default mode should be for the ENG transmitter to return to its full-power level, or to its manually-set power level. It is imperative that a DRL system never be the cause of a lost incoming COFDM feed.

4.3.2 Antenna Requirements

Because in the Beacon Mode the location of an ENG truck (or other ENG platform) relative to an ENG-RO site may not be well known in advance, it is recommended that DRL transmitting and receiving antennas be omni-directional in the azimuth plane. However, in the vertical plane the elevation pattern should be only as broad as necessary to cover the range of depression angles from the ENG-RO site to the operational area of the ENG trucks likely to communicate with the ENG-RO site. The use of an as-narrow-as-practical elevation pattern will minimize the brute force overload (BFO) threat to an ENG receiver on the same tower, while maximizing the link budget for the DRL system.

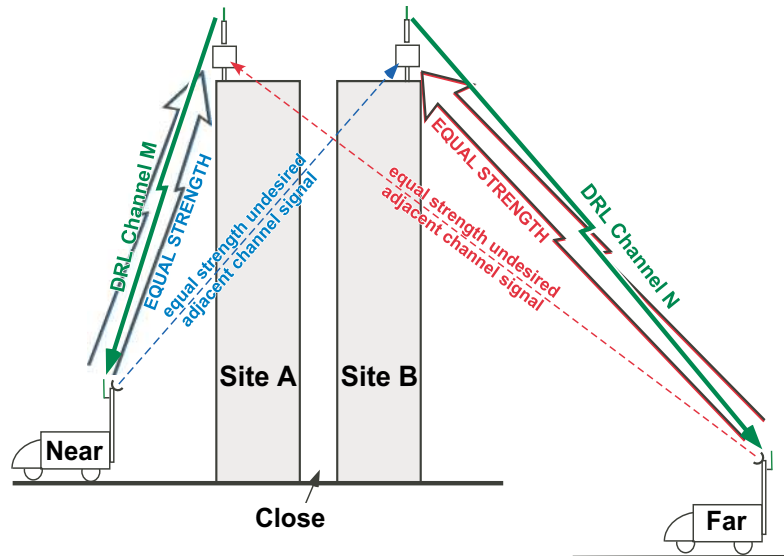

Figure 4.3 ENG-RO site using ATPC via DRL.

For operation in the optional Transport Mode, highly directional antennas may be practical and advisable.

4.4 DRL Coverage Area

Ideally, the path budget for DRL channels will be more robust than the path budget for an incoming ENG feed, so as to ensure that if an ENG-RO site is able to receive a useable incoming COFDM signal, an ENG platform equipped with a DRL receiver will always be able to receive a useable DRL signal (at least in the Beacon Mode).

4.4.1 Microwave Link Budget Analysis

The EIRP of a COFDM TV Pickup (ENG) station is typically 56 dBm, whereas the EIRP of a DRL transmitter will typically be limited to approximately 40 dBm so as to avoid causing BFO to a co-located ENG receiver (even after allowing for some vertical separation between the ENG receiving antenna and the DRL transmitting antenna). However, this possible 16 dB difference in EIRP is offset by the 27 dB difference in channel bandwidths (i.e., 25 kHz vs. 12 MHz), and the use of a highly robust, low-level digital modulation scheme for the DRL signal. Even if the effective range of the DRL signal is less than the effective range of an incoming COFDM signal, an ENG truck close enough to an ENG-RO site to be able to benefit from ATPC and match the RCL of a signal from a distant ENG truck should always be within the effective communications range of a DRL signal.

The overall system link budget values are listed in Table 4.1.

Table 4.1 DRL System Link Budget Values

| Parameter | DRL | COFDM ENG |
|---|----------|-----------|
| Transmitter power output (dBm) | +30 | +37 |
| Cable insertion loss (dB) | -1 | -1 |
| Transmitting antenna gain (dBi) | +9 | +20 |
| Transmitter EIRP | +38 dBm | +56 dBm |
| 2 GHz free space loss at 10 miles (dB) ¹ | -126 | -126 |
| Receiving antenna gain (dBi) | +5 | +20 |
| Received carrier level (RCL) ² | -83 dBm | -50 dBm |
| Receiver thermal noise (dBm/Hz) ³ | -174 | -174 |
| Receiver noise figure (dB) | +4 | +4 |
| Receiver noise bandwidth (dB) ⁴ | +48 | +70 |
| Noise power (No) ⁵ | -122 dBm | -100 dBm |
| Eb/No (QPSK) ⁶ @ BER = 1E-6 | +10.5 dB | |
| C/N (QPSK) with R = 1/2 coding, BER = 1E-6 | +7.5 dB | |
| C/N (64QAM R=2/3, GI=1/32, 24.13bps) | | +16.5 dB |
| DRL link margin (QPSK) dB | +30.6 dB | |
| COFDM link margin (QPSK) 1 dB | | +33.5 dB |
| Notes: | | |
| ¹ The system link budget numbers are under ideal transmitting/receiving conditions in a LOS environment; a non-LOS propagation model has not been factored into the free space line-of-sight (LOS) number. | | |
| ² Assumes receiver cable loss is less than the NF of the receiver. | | |
| ³ At room temperature. | | |
| ⁴ 75 kHz for DRL receiver noise bandwidth; 10 MHz for ENG receiver noise bandwidth. | | |
| ⁵ Assumes an ideal receiver. | | |
| ⁶ These are theoretical values, the practical values are typically 1–2 dB worse. | | |

4.5 RF Watermark Identification

The RF watermark transmitter identification system uses a digital binary sequence with a unique code assigned to each transmitter for transmitter identification (TxID). The TxID receiver can match and recognize each binary sequence to identify the associated transmitter.⁴

The RF watermark is injected at 10 to 20 dB below the desired signal noise threshold level. In this case, assuming the DRL system required S/N is 7 dB, the watermark signal injection level should -18 dB (1/8 the signal amplitude) below the DRL signal average power (See Figure 4.4) so that it will not impact the reception of the DRL signal.

The optimal watermark sequence depends on how many transmitters need to be identified. The larger the transmitter population, the longer the sequence required. Also, each transmitter ID sequence needs to be “distinct” with the others so that it will not be misidentified. The measurement of this “distinctness” or “uniqueness” is the *cross-correlation property* or

4. The RF watermark concept was introduced for DTV applications in ATSC A/110, “Synchronization Standard for Distributed Transmission.” See [3] and [6] for more information.

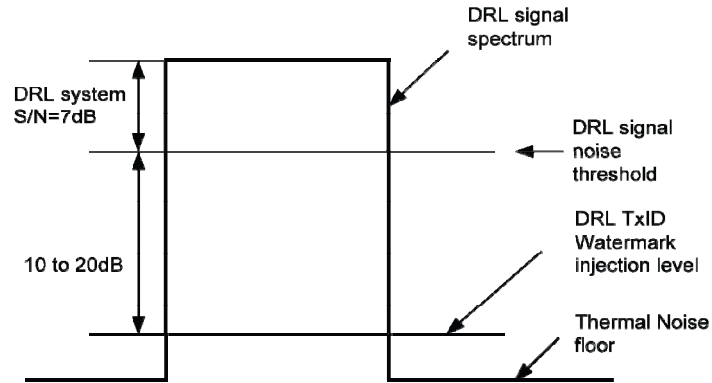

Figure 4.4 DRL RF watermark injection level.

orthogonality among the selected watermark sequences. Some sequences, like the M-sequence, have very good cross-correlation property; but the number of sequences that can be used for transmitter ID is low. For example, a 10-bit M-sequence (sequence period 1023-symbol) can only have 60 distinct sequences for transmitter ID. Meanwhile, a 10-bit Kasami sequence (also 1023-symbol long) can have about 32,000 different sequences; although their cross-correlation property is not as good as the M-sequence, they can still meet the identification requirement. Therefore, a 10-bit Kasami sequence is used to form the DRL TxID sequence.

The transmitter identification sequences can be generated by using shift-registers, as illustrated in Figure 4.5. With different initial conditions of the registers (a_0 to a_3 are 4-bit initial conditions, each can be “0” or “1”), different identification sequences can be generated and assigned to different transmitters. For simplicity, the sequence symbol rate should be the same as the DRL system symbol rate. Figure 4.6a shows a 4-level digital signal eye diagram (no noise). Figure 4.6b shows a 2-level watermark signal injected -20 dB below the 4-level digital signal. It causes slight eye closure, but will have very limited impact (0.04 dB degradation) to the decoding of the 4-level signal.

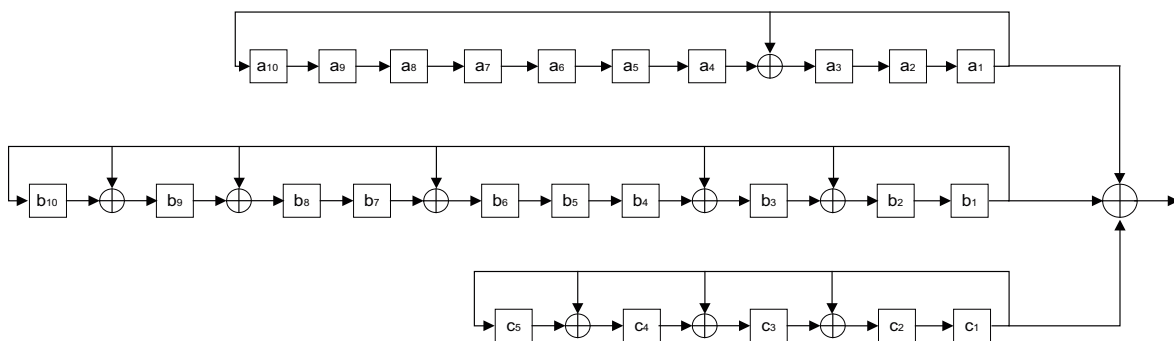

Figure 4.5 Code generator for 10-bit Kasami sequences.

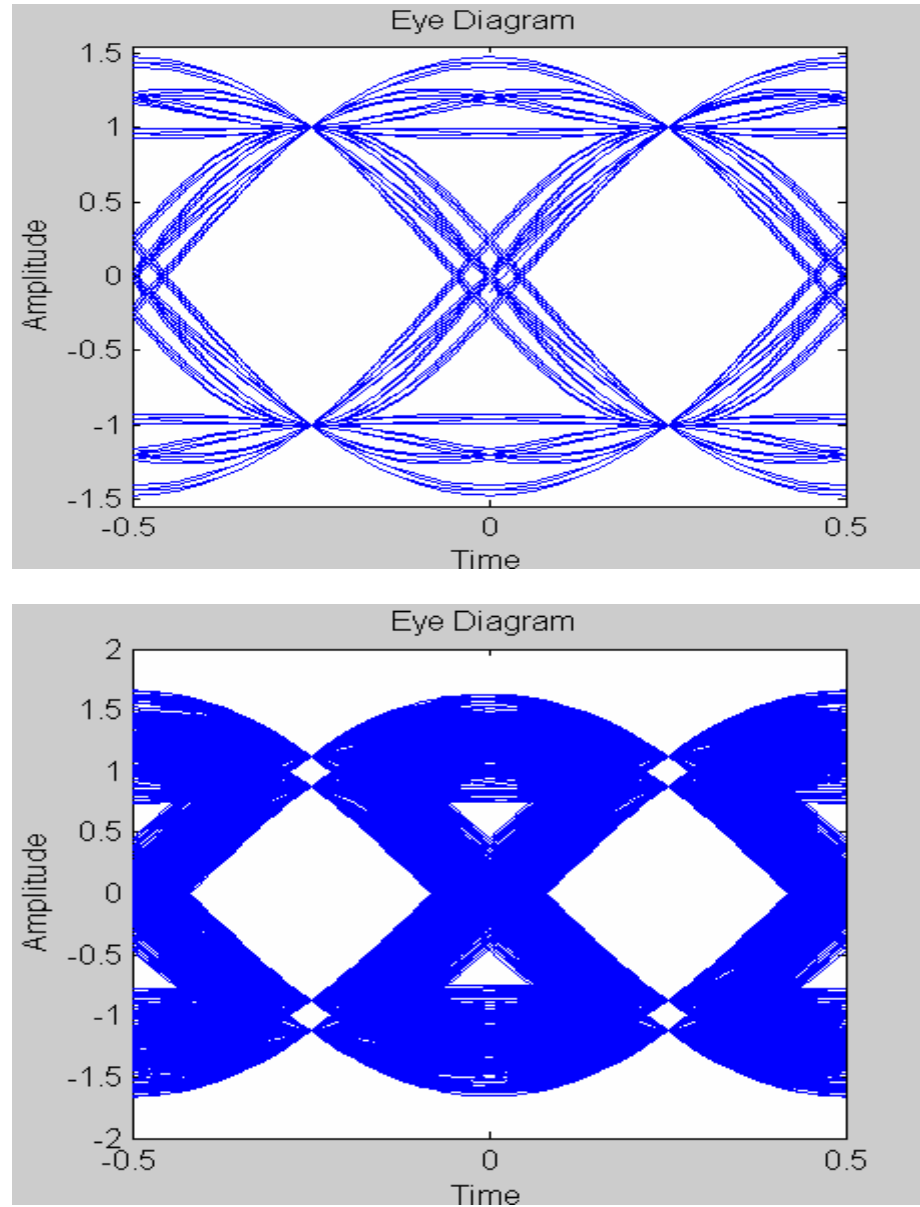

Figure 4.6 Eye diagram before (*top*) and after (*bottom*) insertion of -18dB transmitter ID sequence for QPSK modulated DRL signal.

To reliably identify a transmitter, approximately 1–2 second of the DRL signal is sampled and stored. The processing time is typically within a few seconds.

4.5.1 Insertion of the Sync Sequence

When there is a frame structure (training sequence, handshaking overhead) in the DRL modulated signal, the watermark signal can be inserted in a synchronous way to reduce the identification time. In this case, the frame feature can be used to synchronize the received signal and local transmitter identification (ID) sequence.

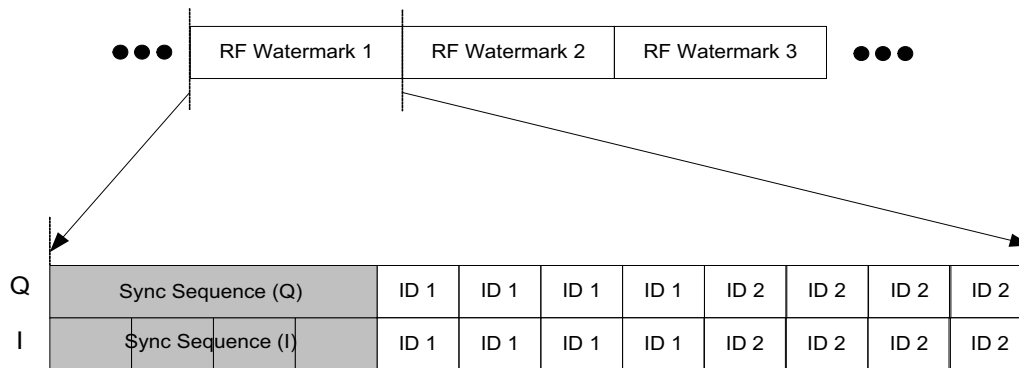

Figure 4.7 Watermark synchronization sequence.

When there is no frame structure in the DRL modulated signal, one additional synchronization sequence can be used, as indicated in Figure 4.7.

4.5.2 Direct Use of the Watermark Signal by COFDM ENG Transmitter

It should be noted that ENG COFDM transmitters may use a watermark signal independently of whether they interface with a DRL system. This permits identification of a noise-like digital signal without having to know the digital coding parameters (e.g., the FEC settings) of the incoming feed). A watermark station identification can also be used with encrypted feeds. That is, a watermark signal embedded in a digital ENG signal can provide basic station identification information (e.g., “KXYZ-TV Truck 5”) without the need to decode the program content.

4.6 DRL Modulation Method

The modulation method chosen for DRL use, and normatively specified in Section 5, is quadrature phase-shift keying (QPSK). This method was determined to provide for optimal use of the 25 kHz DRL channel and at the same time provide adequate data throughput for the two DRL operating modes.

Table 4.2 summarizes the primary modulation and channel coding parameters for the DRL system.

Table 4.2 DRL System Modulation and Channel Coding

| Parameter | Value |
|--|--|
| Data rate | 19.2 kbps |
| Channel forward error correction | R = 1/2 convolutional code (no R-S outer code) |
| QPSK modulation, symbol rate (with 1/2 coding) | 19.2 kbps |
| Roll off factor alpha | 20 percent |
| Bandwidth ¹ | 3dB BW = 19.2 KHz |
| | 20 dB BW = 19.2 x 1.20 = 23.04 kHz |
| Watermark injection level | -18 dB |
| C/N at 1E-6 BER | 7.5 dB |
| Notes: | |
| ¹ There is a 2 KHz guard band (approximately) on each side of the carrier; at 25 kHz BW, side-band attenuation should be > 40 dB with reasonable output-back-off. | |

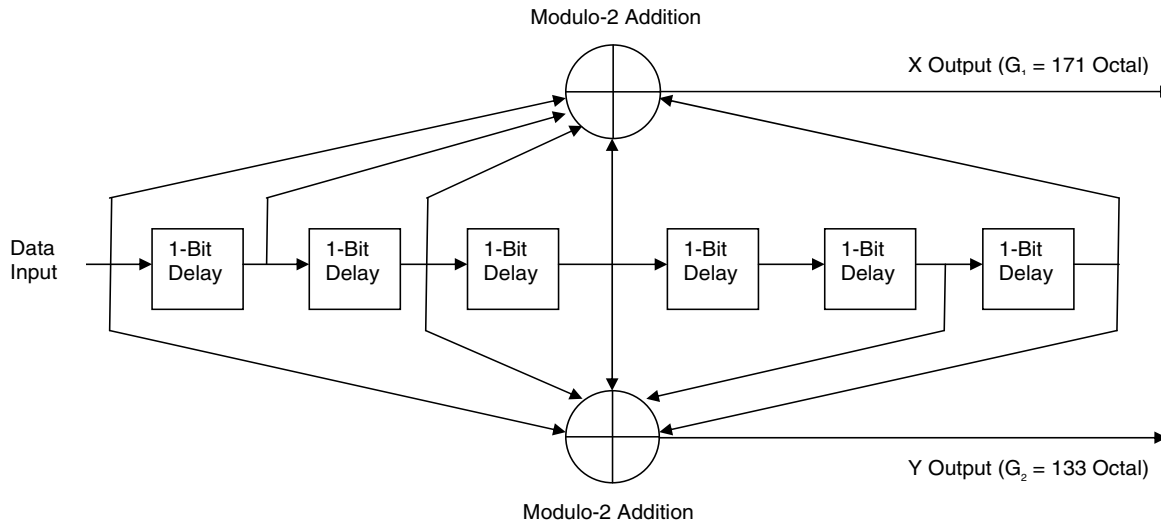

Figure 4.8 The encoder for the convolutional code of rate 1/2.

The $R = 1/2$ convolutional code was selected because it provided the best tradeoff in performance and complexity. The use of an R-S outer code could further reduce the C/N threshold, but an interleaver would then be required to break up the convolutional code errors, which would result in coding/decoding delay. At the relatively low bit rate of the DRL system, this delay would be on the order of seconds—too long for control-signaling applications. Also, an interleaver requires a data frame structure, and so some control and sync bits would need to be added, which would increase the complexity and reduce the data throughput (or increase the bandwidth).

With a $1/2$ convolutional code, no data structure is needed—the code is self-synchronized and decoding can start at any time. The generator polynomials of the convolutional code are $G_1 = 171_{\text{OCT}}$ for X output and $G_2 = 133_{\text{OCT}}$ for Y output (see Figure 4.8). In this figure X and Y refer to the two outputs of the convolutional encoder and are fed to the QPSK modulator. Prior to the QPSK modulation, the I and Q signals (mathematically represented by a succession of Dirac delta functions spaced by the symbol duration $T_s = 1/R_s$, with appropriate sign) are square root raised cosine filtered. The roll-off factor α is 0.2.

The constellation of QPSK modulation is illustrated in Figure 4.9.

4.7 Network Interface Considerations

Although a network interface to the DRL transmitter and from the DRL receiver is not specified in this standard, efficient interconnection of equipments and systems argues in favor of common connector types and protocols. An interface compliant with the IEEE 802.3 10/100BASE-T protocol [7] and using an RJ-45 connector as described in TIA-568-B.2.5 [8] is recommended to support the passage of network data through the DRL system.

5. DRL TRANSMISSION SYSTEM (NORMATIVE)

A DRL transmission system shall conform to the specifications contained in the following subsections.

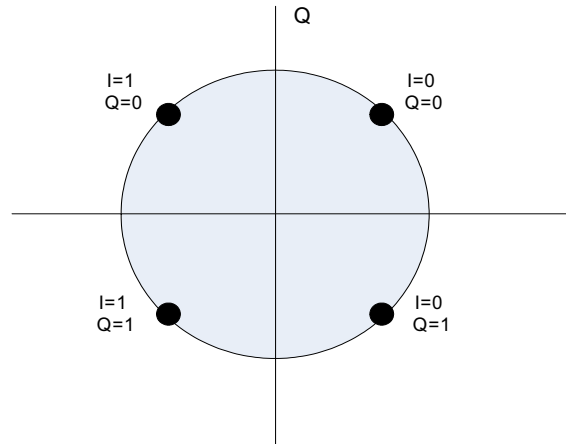

Figure 4.9 The constellation of QPSK modulation.

5.1 DRL Transmitter Architecture

A block diagram of the basic architecture of a DRL transmitter is given in Figure 5.1. The partitioning shown is conceptual, and practical implementations may differ.

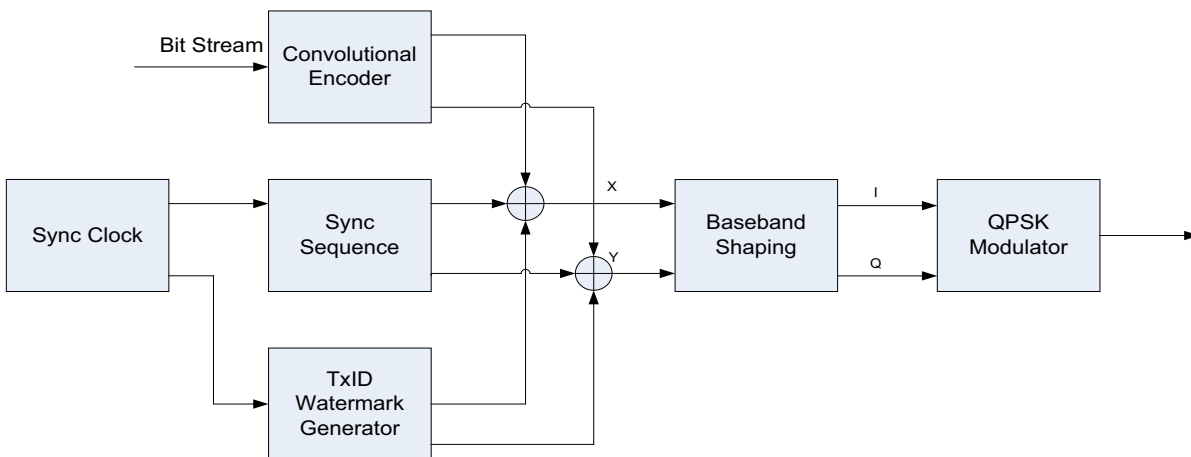

Figure 5.1 Block diagram of a DRL transmitter.

The DRL transmitter shall have the ability to either transmit on user-specified DRL channels (i.e., a home-channel approach), or to select a next available second-adjacent cross-band DRL channel when responding to an incoming COFDM ENG feed. The DRL channels are listed in Table 5.1.

Table 5.1 DRL Channels

| DRL Lower Band | | DRL Upper Band | |
|---------------------------------|------------------|---------------------------------|------------------|
| Channel | Center Frequency | Channel | Center Frequency |
| | | BAS Ch. A7 2109.5000 MHz (edge) | |
| 1 | 2025.0125 MHz | 21 | 2109.5125 MHz |
| 2 | 2025.0375 MHz | 22 | 2109.5375 MHz |
| 3 | 2025.0625 MHz | 23 | 2109.5625 MHz |
| 4 | 2025.0875 MHz | 24 | 2109.5875 MHz |
| 5 | 2025.1125 MHz | 25 | 2109.6125 MHz |
| 6 | 2025.1375 MHz | 26 | 2109.6375 MHz |
| 7 | 2025.1625 MHz | 27 | 2109.6625 MHz |
| 8 | 2025.1875 MHz | 28 | 2109.6875 MHz |
| 9 | 2025.2125 MHz | 29 | 2109.7125 MHz |
| 10 | 2025.2375 MHz | 30 | 2109.7375 MHz |
| 11 | 2025.2625 MHz | 31 | 2109.7625 MHz |
| 12 | 2025.2875 MHz | 32 | 2109.7875 MHz |
| 13 | 2025.3125 MHz | 33 | 2109.8125 MHz |
| 14 | 2025.3375 MHz | 34 | 2109.8375 MHz |
| 15 | 2025.3625 MHz | 35 | 2109.8625 MHz |
| 16 | 2025.3875 MHz | 36 | 2109.8875 MHz |
| 17 | 2025.4125 MHz | 37 | 2109.9125 MHz |
| 18 | 2025.4375 MHz | 38 | 2109.9375 MHz |
| 19 | 2025.4625 MHz | 39 | 2109.9625 MHz |
| 20 | 2025.4875 MHz | 40 | 2109.9875 MHz |
| BAS Ch. A1 2025.5000 MHz (edge) | | | |

5.1.1 General Operating Modes

The DRL system shall employ two modes of operation:

- 1) *Beacon Mode*, which provides for transmitter identification (TxID), automatic transmitter power control of an ENG transmitter via feedback on received carrier level, and other functions—including optional low-speed private data.
- 2) *Transport Mode*, an optional lower-power operating mode that can be used if the RF environment permits.

The initial operating mode of the system shall be the Beacon Mode. The Beacon Mode shall be the default operating mode.

5.2 Microwave/RF Operating Parameters

5.2.1 Transmitter Power Output

No limit on transmitter power output (TPO) is specified, only a limit on equivalent isotropic radiated power (EIRP). Users may achieve up to the maximum authorized EIRP (see Section 5.2.2) however they wish.

5.2.2 EIRP Limitation

The maximum EIRP for a DRL station shall be 10 Watts (40 dBm).

5.2.3 Modulation Method

Quadrature phase-shift keying (QPSK) shall be used. Forward error correction (FEC) shall be used, specifically R = 1/2 convolutional code (no R-S outer code). The resulting data rate is 19.2 kbps.

Prior to the QPSK modulation, the I and Q signals shall be square root raised cosine filtered. The roll-off factor α shall be 0.2.

5.2.4 Frequency Stability

Frequency stability shall be $\pm 0.000\ 005$, or ± 0.05 ppm, equaling approximately ± 100 Hz. Although not required by the standard, it may be advantageous to lock the frequency of the transmitter to a precise external frequency reference such as that available from a GPS receiver.

5.2.5 Channel Tuning Range Requirements

The DRL transmitter shall be capable of a channel tuning range of 2,025.0 – 2,025.5 MHz and 2,109.5 – 2,110.0 MHz, in 25-kHz steps.

5.2.6 Occupied Bandwidth

The occupied bandwidth of the DRL transmitter shall be ≤ 25 kHz. The 3dB bandwidth shall be ≤ 19.2 kHz. The 20 dB bandwidth shall be ≤ 23.0 kHz. See Figure 5.2.

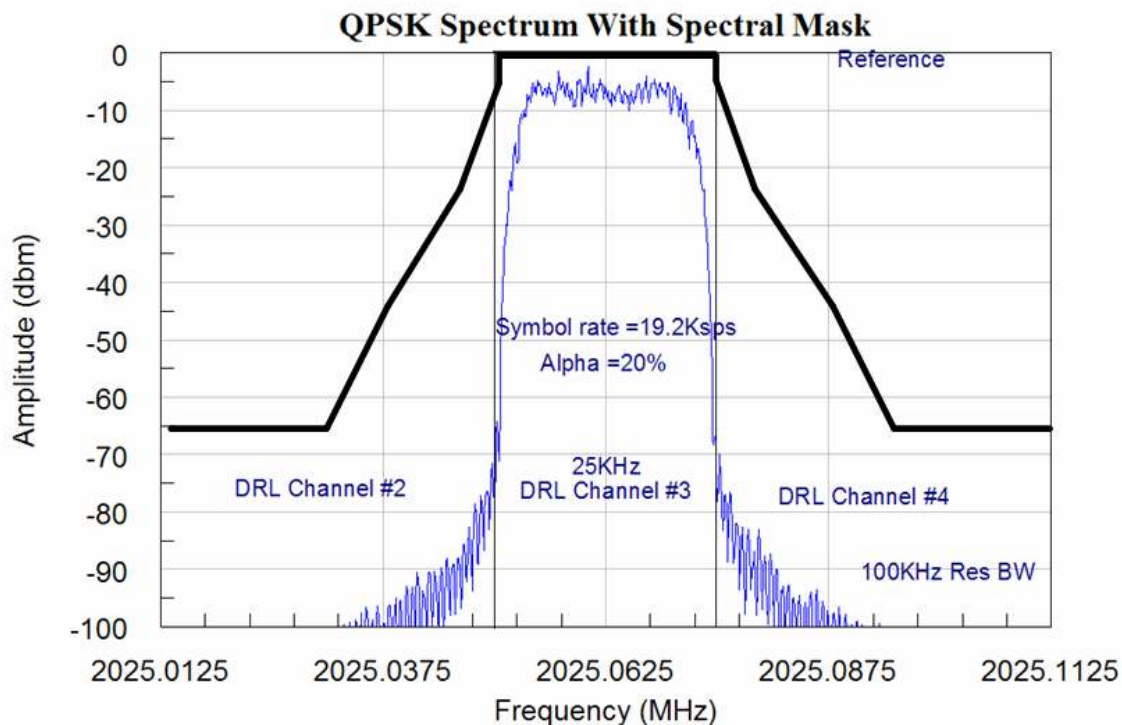

Figure 5.2 DRL channel emission spectrum; frequency vs. amplitude in dB (19.2 kbps, $\alpha = 20$ percent). The FCC spectral mask is shown as an overlay; compliance factor = $10 \log (B_{ref} / B_{res}) = 10 \log (4 \text{ kHz} / 100 \text{ kHz}) = -14 \text{ db}$.

For informational purposes, the FCC spectral mask is shown in Figure 5.2. Specifically:

“For operating frequencies below 15 GHz, in any 4 kHz reference bandwidth (B_{ref}), the center frequency of which is removed from the assigned frequency by more than 50 percent up to and including 250 percent of the authorized bandwidth: as specified by the following equation but in no event less than 50 decibels:

$$A = 35 + 0.8 (G - 50) + 10 \log B$$

Attenuation greater than 80 decibels is not required.

Where:

A = attenuation (in decibels) below the mean output power level

G = percent removed from the carrier frequency

B = authorized bandwidth in megahertz”

5.2.6.1 Adjacent Channel Leakage Ratio

Per Title 47 CFR Section 74.637(a)(2) , ACLR shall be

$$A_{dB} = 35 + 0.8(G - 50) + 10 \log BW_{MHz} \text{ or } 80 \text{ dB, whichever is less}$$

Additionally,

- 50 percent removed = 19 dB attenuation
- 100 percent removed = 59 dB attenuation
- ≥ 126.25 percent removed = 80 dB attenuation

5.2.7 Emission Designator

The emissions designator shall be 25K0G1D.

5.2.8 Antenna Output Interface

The DRL transmitter shall utilize a standard N-fitting output connector.

5.2.9 Transmitting Antenna

Because of the variety of possible ENG applications, the DRL transmitting antenna is not normatively specified in this standard. Implementation guidance is given in Section 4.3.2 and Section 7.

5.3 RF Watermark

Each transmitter shall be assigned a unique transmitter ID (TxID) sequence and conveyed via an RF watermark included as a digital binary sequence injected in the DRL signal.

5.3.1 RF Watermark Parameters

The RF watermark shall consist of several 10 Bit Kasami sequences each with a length of 1K symbols⁵, providing for a total number of identified transmitters = 32K x 32K = 1,024,000,000 possible combinations. The watermark shall be embedded 18 dB below the QPSK modulated data

5. An informative discussion is given in Section 4.5.

signal (about 10 dB below the C/N threshold), or 1/8 of the baseband data signal amplitude. The nominal TxID lockup/decode time shall be less than 5 seconds.

5.3.2 Transmitter Identification

Transmitters shall be individually assigned unique addresses, which may be configured by the user or hard-coded by the vendor. Assignment of TxID values shall be made by a registration authority assigned by the ATSC. The initial registration authority shall be the Society of Broadcast Engineers (SBE)⁶.

5.4 Digital ENG Transmitter Control Metrics

This section specifies the power control range and other parameters relating to the automatic transmitter power control (ATPC) feature of the system.

5.4.1 Transport Stream Structure

The protocol for DRL data transmission shall use a fixed-length packet structure similar to that defined for the MPEG-2 Transport Stream (ISO/IEC 13818-1) [9]. The useful information rate after one-half convolution coding is

$$19.2 \text{ kbit/sec} = 2.4 \text{ kbyte/sec}$$

The update rate for the ATPC metric shall be approximately 200 ms (480 byte/200ms). Supplementary information running on this link shall be conveyed in a 1:5 ratio of APC metric to user data. This results in

$$480/5 = 96 \text{ byte length}$$

The Transport Stream packet structure shall conform to Table 5.2.

Table 5.2 Transport Packet Structure

| Syntax | No. of Bits | Format |
|-------------------------------------|-------------|--------|
| transport_packet() { | | |
| sync_byte | 8 | uimsbf |
| transport_error_indicator | 1 | '1' |
| system_mode | 2 | uimsbf |
| PID | 13 | uimsbf |
| transport_scrambling_control | 2 | uimsbf |
| reserved | 2 | '11' |
| continuity_counter | 4 | uimsbf |
| intended_microwave_txid | 32 | uimsbf |
| payload | 92*8 | uimsbf |
| } | | |

sync_byte – This eight-bit field shall equal '0x47'.

6. See <http://www.sbe.org>

transport_error_indicator – This one-bit field shall equal ‘0’ if the packet contains no error or ‘1’ if the packet contains at least one error.

system+mode – This two-bit field is used for acknowledgement and control of the Beacon Mode of operation. (See Section 5.4.1.4.)

PID – The 13-bit packet identifier. The PID shall conform to Table 5.3.

transport_scrambling_control – This two-bit field shall equal ‘00’ if the payload is not scrambled. Values ‘01’ – ‘11’ shall be user-defined.

reserved – This two-bit field is reserved for use either when revising this standard, or when another standard is issued that builds upon this one.

continuity_counter – This four-bit field shall be incremented with each occurrence of a packet with the same PID.

intended_microwave_txid – This four-byte field is the address of the intended transmitter, as described informatively in Section 4.5.2. This data may be collected automatically from the ENG receiver or programmable via some means by the user. If this data is unavailable, the field shall contain all zeros (‘0’).

payload – This field shall contain 92 bytes of payload, of which two bytes are allocated for RSL and modulation_index functions as specified in Table 5.4.

Table 5.3 Packet Identifier

| PID | Description |
|-----------------|--------------------|
| 0x0000 – 0x0010 | Reserved |
| 0x0011 | APC_control_metric |
| 0x0012 | modulation_command |
| 0x0013 | watermark_return |
| 0x1FFF | Null packet |

The remaining 90 bytes of the payload shall be available to convey private data, details of which may be specified in a future revision of this document or left to individual users and/or vendors to develop.

Note: The PID usage described in Table 5.3 (above) does not conform with A/53, Part 3:2007, Section 6.9 [12].

5.4.1.1 APC Control Metric Parameter

The APC_control_metric (PID = 0x0011) shall be used to return the current link parameters to the remote operator (truck). This information is used to align the antenna, and to relay vital link statistics. This packet shall be sent every 200 ms (approx.). The APC_control_metric shall include two parameters, as listed in Table 5.4.

Table 5.4 APC Control Metric

| Parameter | No. of Bits | Format |
|------------------|-------------|--------|
| RSL | 8 | simsbf |
| modulation_index | 8 | uimsbf |

RSL – This eight-bit metric shall convey a signed number indicating the true RSL in dBm.

modulation_index – This eight-bit metric shall convey an index describing the current modulation type of the ENG transmitter, as detailed in Table 5.5.

Table 5.5 Modulation Indicator Enumeration

| modulation_index | Modulation Type |
|------------------|---------------------------------|
| 0 | Modulation cannot be determined |
| 1 | FM |
| 2 | COFDM DVB-T |
| 3 | VSB-ATSC |
| 4 | SCM |
| 5 – 255 | Reserved |

APC metrics as a function of modulation type are detailed in the following sections.

5.4.1.1.1 modulation_index = 0/1

As detailed in Table 5.5, modulation_index = 0 defines the case when the modulation cannot be determined; modulation_index = 1 defines the case when the modulation type is FM. In such situations, the parameters defined in Table 5.6 shall apply.

Table 5.6 Undetermined/FM Modulation (modulation_index = 0/1)

| Parameter | No. of Bits | Format |
|------------------|-------------|--------|
| RSL | 8 | simsbf |
| modulation_index | 8 | uimsbf |

RSL – Defined in Section 5.4.1.1

modulation_index – Defined in Section 5.4.1.1

5.4.1.1.2 modulation_index = 2

As detailed in Table 5.5, modulation_index = 2 defines the case when the modulation type is COFDM. In such situations, the parameters defined in Table 5.7 shall apply.

Table 5.7 COFDM-DVB-T (modulation_index = 2)

| Parameter | No. of Bits | Format |
|---------------------|-------------|--------|
| RSL | 8 | simsbf |
| modulation_index | 8 | uimsbf |
| BW_cofdm | 2 | uimsbf |
| guard_interval | 2 | uimsbf |
| constellation_cofdm | 2 | uimsbf |
| code_rate | 3 | uimsbf |
| reserved | 7 | uimsbf |
| pre_vit | 16 | uimsbf |
| post_vit | 16 | uimsbf |
| UCE | 16 | uimsbf |
| MER | 8 | uimsbf |

RSL – Defined in Section 5.4.1.1

modulation_index – Defined in Section 5.4.1.1.

BW_cofdm – A two-bit field used to indicate the operating bandwidth of the system. The following values shall be used: 6 MHz = ‘00’, 7 MHz = ‘01’, 8 MHz = ‘10’.

guard_interval – A two-bit field used to indicate the guard interval for the system. The following values shall be used: 1/32 = ‘00’, 1/16 = ‘01’, 1/8 = ‘10’, 1/4 = ‘11’.

constellation_cofdm – A two-bit field used to indicate the constellation of the system in use. The following values shall be used: QPSK = ‘00’, 16QAM = ‘01’, 64QAM = ‘10’.

code_rate – A three-bit field used to indicate the code rate of the system. The following values shall be used: 1/2 = ‘000’, 2/3 = ‘001’, 3/4 = ‘010’, 5/6 = ‘011’, 7/8 = ‘100’.

pre_vit – A two-byte field used to indicate the bit error rate over the microwave link before Viterbi error correction is applied. The first byte shall be the integer portion and the second shall be the exponent. (For example, for a BER of 2e-6, the first byte is 2 and the second is –6.)

post_vit – A two-byte field used to indicate the bit error rate over the microwave link after all error correction is applied. This is the final BER indicator for the microwave link. The first byte shall be the integer portion and the second shall be the exponent. (For example for a BER of 2e-6, the first byte is 2 and the second is –6.)

UCE – A two-byte field used to indicate the number of uncorrectable packets over the microwave link. The two-byte field shall be used to show the number of raw uncorrectable packets. (For example for 256 uncorrectable packets the following notation will apply: ‘00000001 00000000’.)

MER – An eight-bit field used to indicate the modulation error ratio (MER) of the receive signal over the microwave link. Modulation error ratio is a measure of the constellation cluster variance due to any impairment imperfections measured relative to the ideal constellation point locations.

5.4.1.1.3 modulation_index = 3

As detailed in Table 5.5, modulation_index = 3 defines the case when the modulation type is VSB ATSC. In such situations, the parameters defined in Table 5.8 shall apply.

Table 5.8 VSB ATSC (modulation_index = 3)

| Parameter | No. of Bits | Format |
|--------------------|-------------|--------|
| RSL | 8 | simsbf |
| modulation_index | 8 | uimsbf |
| SNR | 8 | uimsbf |
| constellation_atsc | 3 | uimsbf |
| reserved | 13 | |
| reserved | 32 | |
| UCE | 16 | uimsbf |

RSL – Defined in Section 5.4.1.1

modulation_index – Defined in Section 5.4.1.1

SNR – An eight-bit field used to indicate the signal to noise ratio over the microwave link. (For example the following would indicate a SNR value of 22 db: ‘00010110’.

constellation_atsc – A three-bit field used to indicate the constellation of the system in use. The following values shall be used: 2VSB = ‘000’, 4VSB = ‘001’, 8VSB = ‘010’, 8VSB = ‘011’, 16VSB = ‘100’.

UCE – Defined in Section 5.4.1.1.2

5.4.1.1.4 modulation_index = 4

As detailed in Table 5.5, modulation_index = 4 defines the case when the modulation type is SCM. In such situations, the parameters defined in Table 5.9 shall apply.

Table 5.9 Single Carrier Modulation (modulation_index = 4)

| Payload | No. of Bits | Format |
|--------------------|-------------|--------|
| RSL | 8 | simsbf |
| modulation_index | 8 | uimsbf |
| SNR | 8 | uimsbf |
| constellation_sc | 3 | uimsbf |
| reserved | 13 | uimsbf |
| convolutional_code | 4 | uimsbf |
| reserved | 26 | |
| UCE | 16 | uimsbf |

RSL – Defined in Section 5.4.1.1

modulation_index – Defined in Section 5.4.1.1

SNR – Defined in Section 5.4.1.1.3

constellation_sc – A three-bit field used to indicate the constellation of the system in use. The following values shall be used: QPSK = ‘000’, 16QAM = ‘001’, 32QAM = ‘010’, 64QAM = ‘011’, 8-PSK = ‘100’, TBD-2 = ‘101’, TBD-3 = ‘110’.

convolutional_code – A four-bit field indicating the type of convolution code. The following enumeration shall be used: 1/2 = ‘0000’, 2/3 = ‘0001’, 3/4 = ‘0010’, 5/6 = ‘0011’, 7/8 = ‘0100’, 8/9 = ‘0101’.

UCE – Defined in Section 5.4.1.1.2

5.4.1.2 Modulation Command Parameter

The modulation_command (PID = 0x0012) shall be used to request the ENG transmitter to change operating modes. This request may include one or more of the following parameters:

- Modulation standard – FM, COFDM, VSB, SCM
- Modulation parameter – QPSK, 16QAM
- Power level – high, low, variable

Table 5.10 enumerates the modulation command parameters.

Table 5.10 Modulation Command Enumeration

| modulation_command | Modulation Type |
|---------------------------|------------------------|
| 0 | Generic |
| 1 | FM |
| 2 | COFDM DVB-T |
| 3 | VSB-ATSC |
| 4 | SCM |
| 5 – 255 | Reserved |

Parameters for specific modulation_command modes are given in the following sections.

5.4.1.2.1 modulation_command = 0

As detailed in Table 5.10, modulation_command = 0 defines the case when the modulation command type is generic, or otherwise unknown. In such situations, the parameters defined in Table 5.11 shall apply.

Table 5.11 Generic (modulation_command = 0)

| Parameter | No. of Bits | Format |
|------------------|--------------------|---------------|
| power | 8 | simsbf |
| modulation_index | 8 | uimsbf |

power – An eight-bit signed number indicating the amount of excess power being received at the central receive site.

modulation_index – Defined in Section 5.4.1.1

5.4.1.2.2 modulation_command = 1

As detailed in Table 5.10, modulation_command = 1 defines the case when the modulation command type is FM. In such situations, the parameters defined in Table 5.12 shall apply.

Table 5.12 FM (modulation_command = 1)

| Parameter | No. of Bits | Format |
|------------------|--------------------|---------------|
| power | 8 | simsbf |
| modulation_index | 8 | uimsbf |
| BW_fm | 1 | uimsbf |
| reserved | | uimsbf |

power – Defined in Section 5.4.1.2.1

modulation_index – Defined in Section 5.4.1.1

BW_fm – A one-bit field indicating the operating bandwidth of the FM system. The following values shall be used: 3 MHz = '0', 4 MHz = '1'.

5.4.1.2.3 modulation_command = 2

As detailed in Table 5.10, modulation_command = 2 defines the case when the modulation command type is COFDM-DVB-T [13]. In such situations, the parameters defined in Table 5.13 shall apply.

Table 5.13 COFDM-DVB-T (modulation_command = 2)

| Parameter | No. of Bits | Format |
|---------------------|-------------|--------|
| power | 8 | simsbf |
| modulation_index | 8 | uimsbf |
| BW_cofdm | 2 | uimsbf |
| guard_interval | 2 | uimsbf |
| constellation_cofdm | 2 | uimsbf |
| code_rate | 3 | uimsbf |
| reserved | 7 | uimsbf |

power – Defined in Section 5.4.1.2.1

modulation_index – Defined in Section 5.4.1.1

BW_cofdm – Defined in Section 5.4.1.1.2

guard_interval – Defined in Section 5.4.1.1.2

constellation_cofdm – Defined in Section 5.4.1.1.2

code_rate – Defined in Section 5.4.1.1.2

5.4.1.2.4 modulation_command = 3

As detailed in Table 5.10, modulation_command = 3 defines the case when the modulation command type is VSB-ATSC. In such situations, the parameters defined in Table 5.14 shall apply.

Table 5.14 VSB-ATSC (modulation_command = 3)

| Payload | No. of Bits | Format |
|--------------------|-------------|--------|
| power | 8 | simsbf |
| modulation_index | 8 | uimsbf |
| constellation_atsc | 3 | uimsbf |
| BW_sc | 5 | uimsbf |
| reserved | 32 | uimsbf |

power – Defined in Section 5.4.1.2.1

modulation_index – Defined in Section 5.4.1.1

constellation_atsc – Defined in Section 5.4.1.1.3

BW_sc – This five-bit field describes the bandwidth in MHz (e.g., 0x03 = 3 MHz, 0x1F = 31 MHz). A value of 0x06 shall be ATSC-compliant.

5.4.1.2.5 modulation_command = 4

As detailed in Table 5.10, modulation_command = 4 defines the case when the modulation command type is SCM. In such situations, the parameters defined in Table 5.15 shall apply.

Table 5.15 SCM (modulation_command = 4)

| Payload | No. of Bits | Format |
|--------------------|-------------|--------|
| power | 8 | simsbf |
| modulation_index | 8 | uimsbf |
| BW_sc | 5 | uimsbf |
| constellation_sc | 3 | uimsbf |
| convolutional_code | 4 | uimsbf |
| reserved | 32 | uimsbf |

power – Defined in Section 5.4.1.2.1

modulation_index – Defined in Section 5.4.1.1

BW_sc – Defined in Section 5.4.1.2.4

constellation_sc – Defined in Section 5.4.1.1.4

convolutional_code – Defined in Section 5.4.1.1.4

5.4.1.3 Watermark Return Parameter

The watermark_return (PID = 0x0013) shall be used to return the RF watermark of the signal currently being received by the central receiver to the remote location (truck). The format shall comply with the syntax in Table 5.16.

Table 5.16 Watermark Return Parameters

| Parameter | No. of Bits | Format |
|-------------------------------|-------------|--------|
| number_of_received_watermarks | 8 | uimsbf |
| received_watermark_1 | 32 | uimsbf |
| received_watermark_2 | 32 | uimsbf |
| received_watermark_n | 32 | uimsbf |

number_of_received_watermarks – An eight bit field used to report to the DRL receiver the number of watermarks identified at the central receive site.

received_watermark_1 – A four-byte field conveying the watermark of receiver 1.

received_watermark_2 – A four-byte field conveying the watermark of receiver 2.

received_watermark_n – A four-byte field conveying the watermark of receiver n.

5.4.1.4 Beacon Operational Mode

As previously mentioned in Section 5.1.1, the DRL system will employ the Beacon Mode as the default mode of operation. Utilizing the transport stream structure as defined in Section 5.4.1, the Beacon Mode provides the necessary feedback to the digital ENG transmitter for automatic transmitter power control and optional low speed private data.

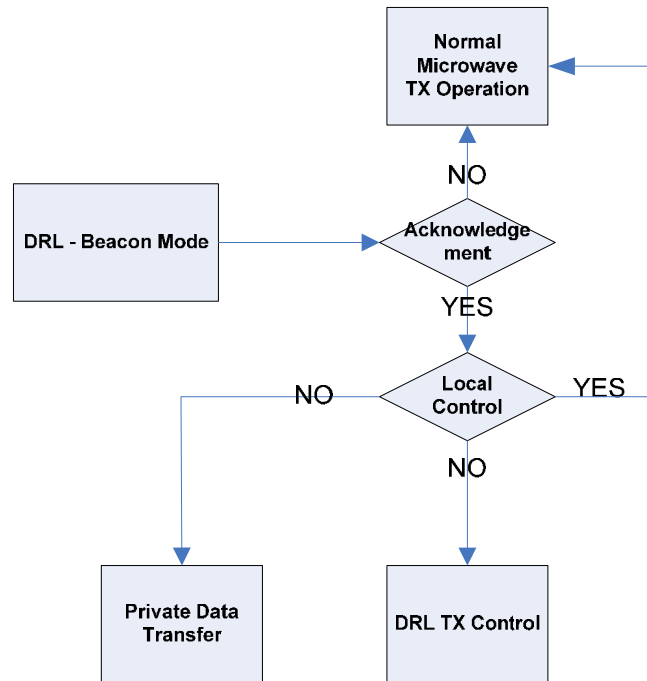

Figure 5.3 Beacon Mode operation (microwave transmitter interface).

Within the syntax of the transport stream packet structure, a two-bit `system_mode` field shall be utilized to signal operation of the Beacon Mode. The microwave ENG transmitter shall use the `system_mode` field to enable the DRL control system within the Beacon Mode of operation.

Once Beacon Mode status has been acknowledged by the microwave transmitter, control metrics shall be supported utilizing the given transport stream per the logic diagram of Figure 5.3.

Instantaneous loss of Beacon Mode acknowledgment by the microwave transmitter shall not cause a default condition for the microwave transmitter. The microwave transmitter shall only default after a time-out period that is adjustable by the user.

5.5 Data Interfaces

Two functional application interfaces shall be provided to interface the DRL transmitter with related equipment:

- 1) **Control Interface:** a dedicated direct control interface to the ENG microwave receive site equipment. This interface is used to pass ENG control metrics and link status messages to the DRL transmitter and—ultimately—back to the remote truck.
- 2) **Network Interface:** a dedicated, independent, network data link input to the DRL transmitter. This interface is used to provide for private data transmission back to the remote truck.

5.5.1 Control Interface

A TIA-422⁷ control interface [2] shall be utilized to interface directly with the DRL transmitter. The interface shall utilize a 9 pin D male connector. The pin-out listed in Table 5.17 shall be used.

Table 5.17 Control Interface Pin-Out

| Pin No. | Function |
|---------|----------|
| 1 | GND |
| 2 | RX- |
| 3 | TX- |
| 4 | NC |
| 5 | GND |
| 6 | NC |
| 7 | TX+ |
| 8 | RX+ |
| 9 | NC |

The TIA-422 interface [2] shall utilize a balanced differential line connection and have a minimum threshold line detection of 200 mV peak-to-peak with a high impedance input.

Note: Currently, some microwave ENG receiving equipment use a combination of serial RS-232 and serial TIA-422 [2] for communications control connections to supply quality metrics such as S/N, LQ, RCL, post-Viterbi BER, and so on.

The utilization of the TIA-422 [2] style interface should allow for common mode rejection (for noise immunity) and supply sufficient line drive capability to separate equipment by up to 100 meters.

5.5.2 Network Interface

The network interface is not normatively specified in this standard. Informative implementation guidance is given in Section 4.7.

6. DRL RECEIVER SYSTEM (INFORMATIVE)

It is beyond the scope of this document to specify the design of a DRL system receiver. The following sections are intended to provide guidance to implementers on the basic features and operational capabilities needed in a DRL receiver.

6.1 Basic Functionality Overview

The DRL receiver recovers the information representing the original input data from the modulated signal emitted by the DRL transmitter. In particular, the receiver performs the following functions:

- Tunes the selected 25 kHz channel
- Rejects adjacent channels and other sources of interference
- Demodulates the received signal, applying error correction to produce a transport bit stream
- Identifies the elements of the bit stream using a transport layer processor

7. More commonly know by its previous designation, “RS-422.”

- Select each desired element and decodes it appropriately

Noise, interference, and multipath are elements of the terrestrial transmission path, and the receiver circuits are expected to deal with these impairments. Innovations in equalization, automatic gain control, interference cancellation, and other techniques create product performance differentiation and improve overall operation.

A cursory examination of the typical operating environment of a DRL receiver reveals that these devices operate in a harsh RF environment. Implementers need to be mindful that there will typically be users above and below the operating channel. Double-conversion front-ends may be one solution; direct-demodulation techniques may be another.

The decoding of transport elements that make up the data stream is usually considered to be a more straightforward implementation of specifications, although opportunities for innovation in circuit efficiency exist here as well.

6.1.1 Receiver Block Diagram

Figure 6.1 provides a high level view of the DRL receiver. This view is not intended to be complete, but instead to illustrate the relationship of the various operating elements.

6.1.2 Basic Receiver Functions

The DRL receiver should be frequency agile such that it has the capability to be tuned to any of the fifty 25 kHz channels as outlined in Table 5.1. A control interface should be provided that allows users to select the appropriate DRL channel.

It should also provide for full compatibility with an existing DRL transmitter such that full functionality can be achieved. It should support the RF demodulation of the QPSK constellation and the RF watermark, which is used to identify the appropriate microwave ENG central receive site as described in Section 5.3 of this standard.

As outlined in Section 6.3.2, a TX ENG control interface will be utilized to supply the necessary control metrics to the microwave transmitter for ATPC. It will also provide the necessary network data interface for private data applications as described in Section 6.3.3.

6.2 Microwave/RF

6.2.1 Channel Tuning Range

The DRL receiver should be capable of a channel tuning range of 2,025.0 – 2,025.5 MHz and 2,109.5 – 2,110.0 MHz, in 25-kHz steps.

6.2.2 Frequency Stability

It is recommended that the frequency stability of the receiver match the normatively specified transmitter frequency stability of $\pm 0.000\ 005$, or ± 0.05 ppm, equaling approximately ± 100 Hz (see Section 5.2.4). It may be advantageous to lock the frequency of the receiver to a precise external frequency reference such as that available from a GPS receiver.

6.2.3 Adjacent Channel Rejection Ratio

Adjacent channel interference is a combination of the adjacent channel leakage ratio (ACLR, a transmitter or emission mask function) and the adjacent channel rejection ratio (ACRR, a receiver selectivity function). The combination of these two effects is the adjacent channel interference ratio:

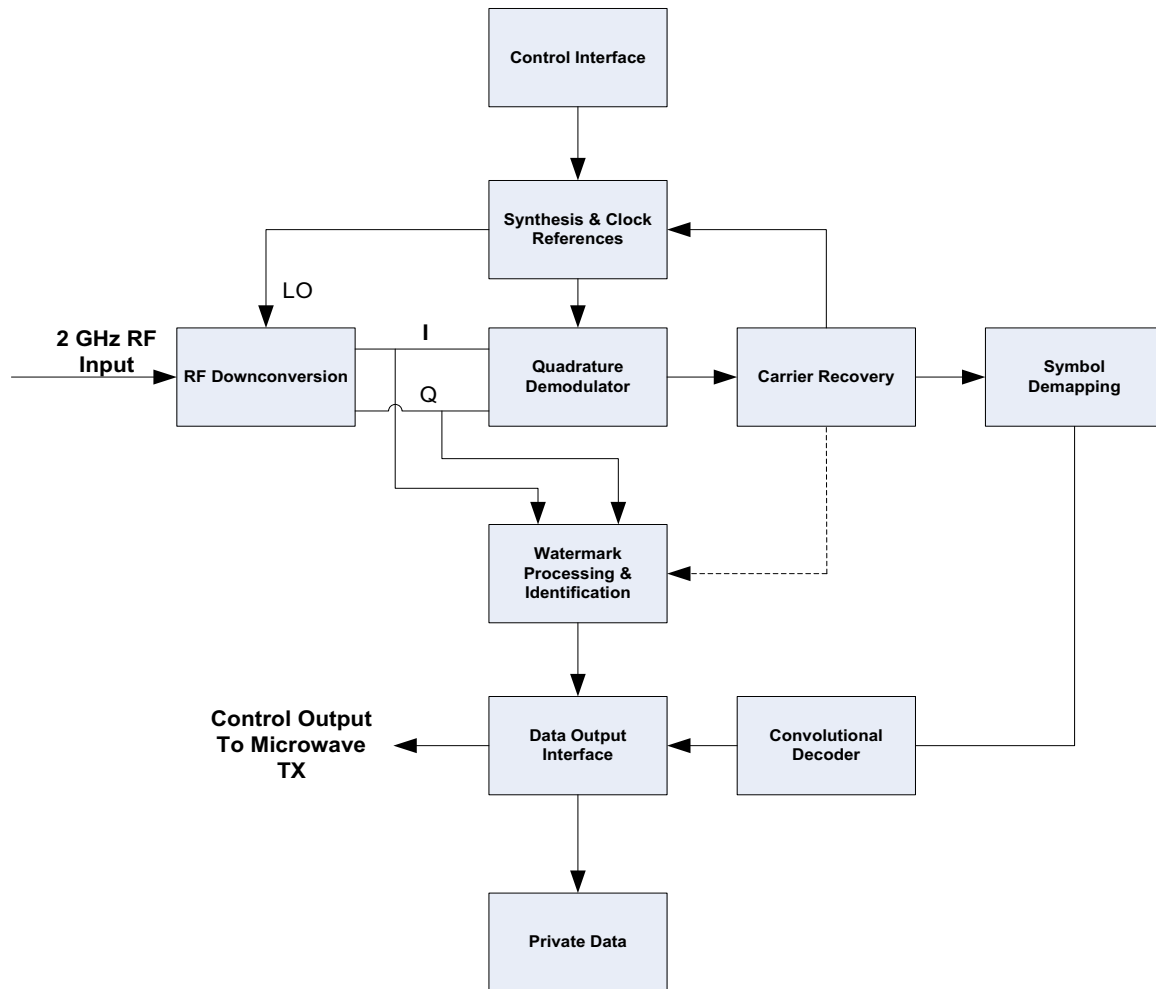

Figure 6.1 Basic block Diagram of a DRL receiver.

$$ACIR = 1/[(1/ACLR) + (1/ACRR)]$$

A good design will balance ACLR and ACRR. For example, if the best possible ACLR is -60 dB, a DRL receiver with an ACRR that is 20 dB better, or -80 dB, is all that is required; i.e.,

$$-60 \text{ dB} + (-80 \text{ dB}) = -59.96 \text{ dB}$$

or only a 0.04 dB degradation. Furthermore, if the ACRR that is practical is -50 dB, then there would be little point in making the ACLR any more stringent than -70 dB, as

$$-50 \text{ dB} + (-70 \text{ dB}) = -49.96 \text{ dB}$$

or, again, just a 0.04 dB degradation.

6.3 Physical Input/Output

Because interoperability of DRL hardware from one vendor to another is an important operational benefit to end-users, it is recommended that the input and output connections on the DRL receiver conform with the guidelines given in the following sections.

6.3.1 Antenna Input Interface

It is recommended that an N-connector be used for the RF antenna input.

6.3.2 Control Interface

It is recommended that a TIA-422 [2] control interface be provided to interface the DRL receiver directly with the ENG receiver, utilizing a 9 pin D male connector with a pin-out as listed in Table 5.17 (above).

It is recommended that the TIA-422 [2] interface utilize a balanced differential line connection and have a minimum threshold line detection of 200 mV peak-to-peak with a high impedance input.

Note: The utilization of the TIA-422 [2] style interface should allow for common mode rejection (for noise immunity) and supply sufficient line drive capability to separate equipment by up to 100 meters.

6.3.3 Network Interface

It is recommended that an interface compliant with the IEEE 802.3 10/100BASE-T protocol [7] and using an RJ-45 connector as described in TIA-568-B.2.5 [8] be utilized to support the delivery of system data.

6.3.4 Control/Monitor Interface

During setup of a DRL system it may be useful for the user to have the capability to interrogate the system using a dedicated control device or a laptop computer. In the latter case, this capability may be facilitated by the use of SNMP over IP. Individual vendors may choose to offer software designed to permit users to set up, maintain, and troubleshoot the DRL system using a laptop computer or similar instrument.

7. DRL SYSTEM IMPLEMENTATION CONSIDERATIONS (INFORMATIVE)

The launch of any new radio service brings with it implementation issues that can only be identified and solved when practical devices are constructed and put into field operation. The following sections outline some of the potential issues identified during the DRL system design phase.

7.1 Coordination Requirements for Multi-Station Central Receiver Sites

Because a DRL transmitting antenna typically will be collocated with an ENG receiving antenna, the potential for self-interference exists. However, as long as at least 10 feet (3.0 meters) of vertical spacing between and ENG receiving antenna and a DRL transmitting antenna can be maintained, the receiver selectivity should be able to tolerate (i.e., reject) the “undesired” DRL signal.

One manufacturer’s tests show that a COFDM receiver operating on TV BAS Channel A1d (2,025.5–2,037.5 MHz) should be able to reject a Channel DRL20 signal at 2,025.4875 MHz so

long as a desired-to-undesired signal ratio of -30 dB is not exceeded, using a no more than a 1 dB degradation in the noise floor interference criteria (i.e., the TSB-10F interference criteria).

If we assume a -93 dBm noise threshold for a COFDM receiver, then the undesired DRL Channel 20 signal at the ENG receiver input cannot exceed -63 dBm. Using a Kathrein Model OGB11-1900D omnidirectional PCS antenna as a surrogate for a DRL transmitting antenna, the elevation pattern for that antenna at 90° upwards shows a suppression of 26 dB, and a suppression of 40 dB for 90° downwards. Assuming that the ENG-RO receiving antenna will be mounted above the DRL transmitting antenna, the more conservative -26 dB vertical pattern suppression will be used.

Elevation pattern data for two widely used ENG central receive antennas, one a fixed, sector antenna, and the other a steerable antenna, show elevation pattern suppressions at 90° downwards of 42 dB for the sector antenna and 32 dB for the steerable antenna. Again, to be conservative, the lower suppression value will be used. Thus, the combined isolation due to the two elevation patterns together will be taken as -26 dB plus -32 dB, or -58 dB total.

The maximum proposed EIRP for a DRL signal is 40 dBm. For the undesired DRL signal to not exceed -63 dBm at the input port of the ENG receiver, an isolation of at least 103 dB is required. Since 58 dB of isolation will be provided by the elevation patterns of the DRL transmitting antenna and the ENG receiving antenna, this means that the FSPL between the two antennas has to be at least 45 dB. At 2 GHz, this represents a distance of 6.9 feet. If the vertical separation is 10 feet, the FSPL increases to 48.2 dB; at 20 feet, the FSPL increases to 54.2 dB; and at 30 feet, the FSPL increases to 57.7 dB.

Accordingly, if there is at least 10 feet of vertical separation between a DRL transmitting antenna and an ENG receiving antenna, the DRL signal should not cause interference to even a very weak incoming COFDM ENG signal.

The problem becomes more difficult if there is more than one ENG-RO facility at a particular site, because now the coupling between Station A's DRL transmitting antenna and Station B's ENG-RO antenna, and vice-versa, will need to be considered. And, the angles between those antennas may no longer be $\pm 90^\circ$. If frequency coordination between co-located ENG-RO facilities, each desiring to use DRL channels, show insufficient isolation to ensure a D/U ratio of no worse than -30 dB between an immediately adjacent DRL channel, protocols could be established to "lock out" some combinations of DRL channels. For example, if Station B is receiving on Channel A7d (2,097.5–2,109.5 MHz), then Station A might agree to not use DRL Channels 21 through, say, 30, from its collocated (or nearly collocated) ENG-RO/DRL site.

7.2 Emission Mask Measurement

The use of an advanced ENG tool such as the DRL system carry with it an incumbent responsibility that any new proposed transmission will not interfere with other existing users of the BAS band, including incoming ENG feeds to a collocated central receive site, or with other adjacent services. Determining how to measure compliance with this requirement can be complicated, as test equipment settings and connections can have an appreciable impact on the data that is derived. A detailed discussion of DRL emission mask measurement is beyond the scope of this standard. Interested readers are referred to TIA-102.CAAA-B, "Digital C4FM/CQPSK Transceiver Measurement Methods," which may provide useful guidance in this area [10]. Although this TIA standard was written for digital signals at 1 GHz and below, and portions of the standard are unique to trunked radio systems, it is believed that Section 2.2 ("Method of

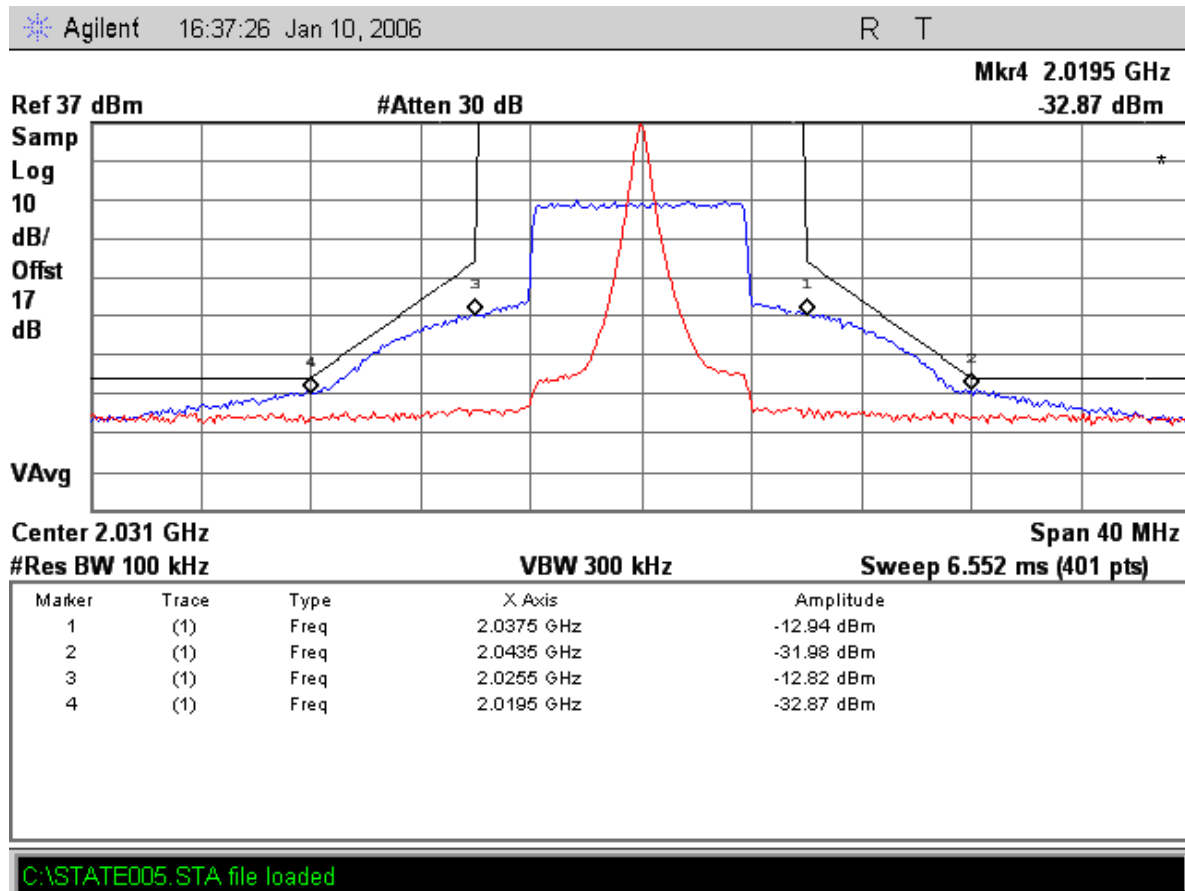

Figure 7.1 Typical ENG spectrum vs. FCC mask.

Measurement for Transmitters”), pages 71–114, are applicable to the measurement of narrowband DRL channels at 2 GHz.

7.3 Analysis of Channel 1/7 Interference with the DRL Receiver

An ENG transmitter operating on channel 1 or channel 7 holds the possibility of interference into a nearby a DRL receiver under certain circumstances. This type of interference will occur when multiple transmitters are co-located at a given site and transmitting back to a common central receive site.

Figure 7.1 shows a typical ENG transmitter output spectrum with the FCC mask overlaid. It can be seen that spectral regrowth will act as an inference source to co-located DRL receivers.

The FCC mask [11] specifies the power level at the band edge to be 50 dB down from the mean power. In the Figure 7.1 plot, *marker 3* is below the FCC mask; however, this performance cannot be guaranteed across manufacturers. For the calculation of interference, a 50 dB value (in a 4 kHz BW) will be used. Furthermore, for simplicity, the power level of the interference will be assumed to be flat across the entire DRL band. Table 7.1 provides an analysis of the influence of this interference on DRL receiver performance.

Table 7.1 Analysis of ENG Interference into DRL Receiver

| Parameter | DRL System | Case 1: COFDM Interference to DRL RX (Worst Case) | Case 2: COFDM Interference to DRL RX (Offset Antenna) |
|--|------------|---|---|
| Transmitter power output (dBm) | 30 | 37 | 37 |
| Cable insertion loss (dB) | -1 | -1 | -1 |
| Transmitting antenna gain (dBi) ¹ | 9 | 20 | 0 |
| Transmitter EIRP | 38 | 56 | 36 |
| 2 GHz free space loss at 10 miles (dB) ² | -122.6 | -68.1 | -68.1 |
| Receiving antenna gain (dBi) | +5 | 5 | 5 |
| Received carrier level (dBm) | -79.59 | -7.1 | -27.1 |
| FCC Mask @ band edge (dB) ³ | | -50.0 | -50.0 |
| RBW 4->25K (dB) ⁵ | | 8.0 | 8.0 |
| C/N (QPSK) with R = 1/2 coding, BER = 1E-6 | 7.5 | | |
| Interference power caused by COFDM regrowth (dBm) | | -49.2 | -69.2 |
| Fade margin for DRL reception (dB) | | -37.9 | -10.4 |
| ¹ 0dB gain was estimated at a 30 degree offset from the transmit antenna. ² The DRL RCL was calculated at 10 miles and the COFDM interference was calculated at 100 ft. ³ The level was determined using the FCC mask from Part 74.637 [11]. ⁴ $10 \times \log(25 \text{ KHz} / 4 \text{ KHz}) = 8 \text{ dB}$; 25 KHz was used because this is the BW of the DRL channel. | | | |

As detailed in Table 7.1, two cases are calculated:

Case 1: The first is a worst case situation when the ENG transmitter is operating in-line with the DRL receive antenna, as illustrated in Figure 7.2. It can be seen that the DRL receiver will be dominated by this regrowth; i.e., there is a negative fade margin of -37.9 dB.

Case 2: The second is when the DRL receive antenna is offset below the interfering ENG transmitting antenna, as illustrated in Figure 7.3. For the DRL receiver to work properly, the DRL receive antenna must be moved out of the path of the COFDM transmitter.

Under the two situations outlined above, the DRL receiver will not function unless the ENG transmitter interference can be reduced significantly, either by physical separation, shielding, filtering, or some other technique.

An obvious way around this problem would involve frequency coordination of the ENG BAS links so that channels 1 and 7 are used as the last resort. This is unlikely to be a practical solution, however, because in the larger TV markets—where this problem will be the greatest—is exactly where every single one of the available 2 GHz TV BAS channels will almost assuredly be in use;

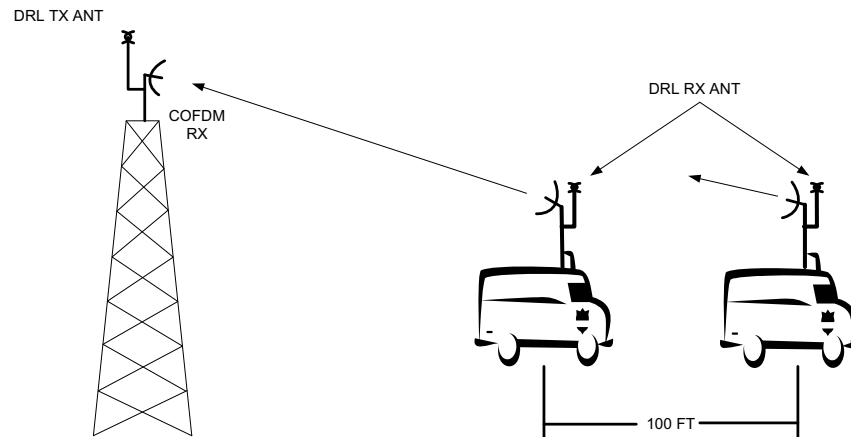

Figure 7.2 DRL receiver in-line with an ENG transmitter (worst case).

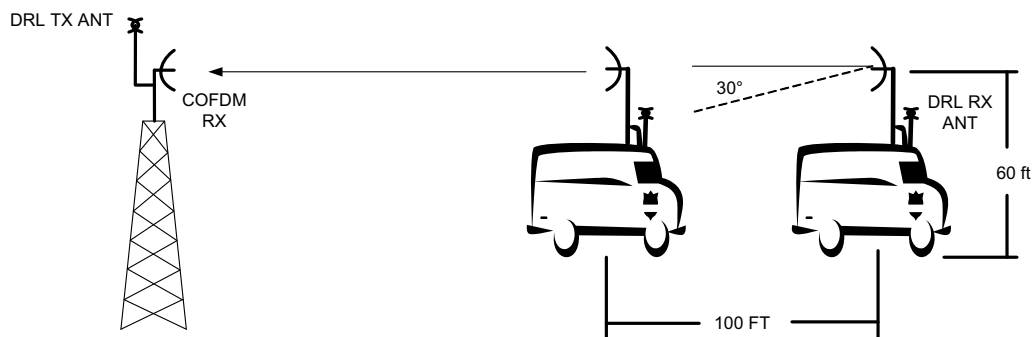

Figure 7.3 DRL RX offset below interfering ENG transmitting antenna.

indeed, it would not be unusual for all, or most, of those channels to be used in split-channel mode.

7.3.1 Possible Solutions

Technologies exist to suppress adjacent channel spill-over; however, most of them are designed to suppress a QAM-type signal when the desired and interference signals utilize the same type of modulation and the same bandwidth. In this case, different types of modulation are used (QPSK vs. OFDM), and different bandwidth are used (8 MHz vs. 25 kHz). Generally speaking, this is a receiver issue; signal processing at the DRL receiver can realistically provide perhaps 10 – 20 dB of improvement. To accomplish this improvement, however, the receiver can become quite complex, since the device needs to characterize (or “know”) the interference in order to “cancel” it.

To solve the adjacent channel interference problem, a combination of different approaches may be needed, including:

- Polarization diversity

- Antenna directivity
- Frequency diversity
- ENG signal sidelobe reduction
- Interference suppression

Work underway as this document was finalized offered a possible solution by using an 11-pole 2-notch filter for the ENG transmitter—one notch at the lower DRL frequency and the other at the upper DRL frequency. Practical implementation issues include the size, weight, and stability of the filter, which could be switched in and out of the circuit as needed.

Another potential solution is to use a 6 MHz bandwidth rather than 8 MHz, operating on the high/low sides of the channels, which effectively provide a 2 MHz operational buffer.

A detailed examination of these elements is beyond the scope of this standard. However, as implementation experience is gained, this document may be updated to provide additional guidance.

Annex A:

D-ENG Feeder Link Identification Watermark (Normative)

A.1 OVERVIEW

This Annex describes the method for encoding a buried spread spectrum RF watermark in the emitted signal of a digital ENG transmitter. Addition of this watermark permits identification of the ENG signal and facilitates ATPC through use of the DRL system described in Section 5 of this standard.

A.2 TRANSMITTER IDENTIFICATION

Transmitters shall be individually assigned unique addresses, which may be configured by the user or hard-coded by the vendor. Assignment of TxID values shall be made by a registration authority assigned by the ATSC. The initial registration authority shall be the Society of Broadcast Engineers⁸.

A.3 D-ENG WATERMARK

The embedding ratio for the D-ENG identification watermark shall be 30–33 dB below the DVB-T signal [13]. Each watermark shall consist of one synchronization sequence followed by a series of transmitter identification sequences. The watermark shall be synchronized to the DVB-T frame structure [13]; i.e., the RF watermark sequence is inserted in a free running mode and reset every 68 OFDM symbols.

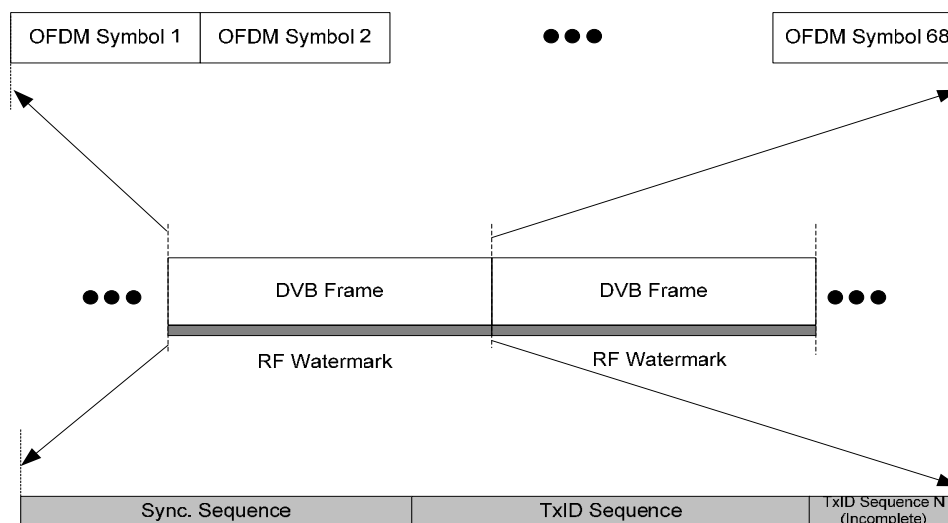

Figure A3.1 Structure of the RF watermark within the DVB frame.

8. See <http://www.sbe.org>

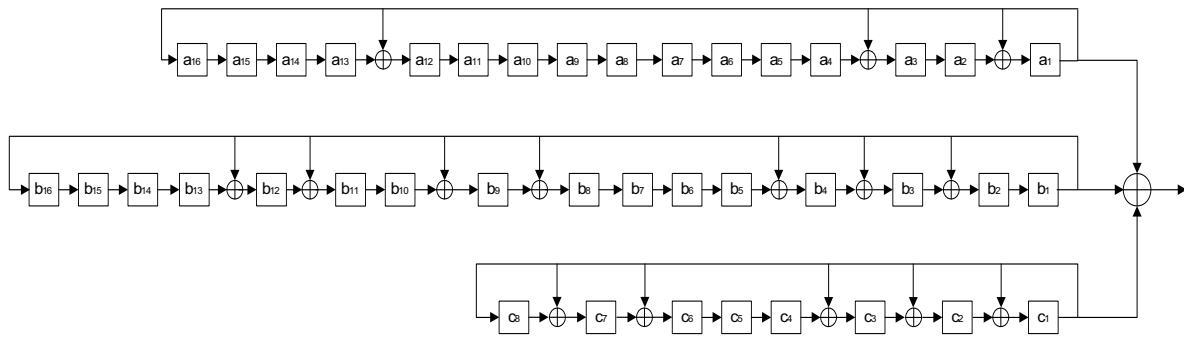

Figure A3.2 Kasami sequence generator (16-bit).

The embedded DENG watermark signal shall carry a 16-bit Kasami sequence that is transmitted repeatedly, synchronized with the host DVB-T frame structure [13] as illustrated in Figure A3.1. The code shall be generated in a group of three shift registers having specified feedback arrangements and set to known values at specified times, as shown in Figure A3.2. The initial setting of the shift registers indicates the identification of the ENG transmitter. The shift registers shall be clocked at the sampling rate of the host DVB-T signal [13]. Provision is made for modulation of the RF watermark signal by a slow speed serial data signal to permit separate data transmission for remote control and other purposes.

Depending on the duration of the guard interval, the length of each DVB-T frame [13] are different, which can be equivalent to 2.1914 to 2.6563 Kasami Sequences. See Table A3.1.

Table A3.1 Kasami Sequences as a Function of Operating Mode

| Guard interval | 1/32 | 1/16 | 1/8 | 1/4 |
|----------------|--------|--------|--------|--------|
| 2k mode | 2.1914 | 2.2578 | 2.3907 | 2.6563 |

The watermark sequence shall be the same as specified for the TxID sequence in A/110A in the section on Identification Code Generation Transmission [3]. Code generator initialization shall be through the pre-loading process specified in the referenced section of A/110A. As a consequence of the 16 bit Kasami Sequence length, representing 2^{16-1} symbols, it is possible through this mechanism to identify a total of more than 16 million transmitters.

A.4 IMPLEMENTATION CONSIDERATIONS (INFORMATIVE)

The receiver must be synchronized with the DVB-T/H frame structure [13] to reduce identification delay and computational complexity by demodulating the TPS signaling.

The TxID watermark can be modulated for data transmission, if desired. The data rate is 53.47 baud for 2k mode with one-quarter guard interval. When 1/32 guard interval is used, the data rate becomes 63 baud). For the 4k or 8k mode, the data rate will be higher.

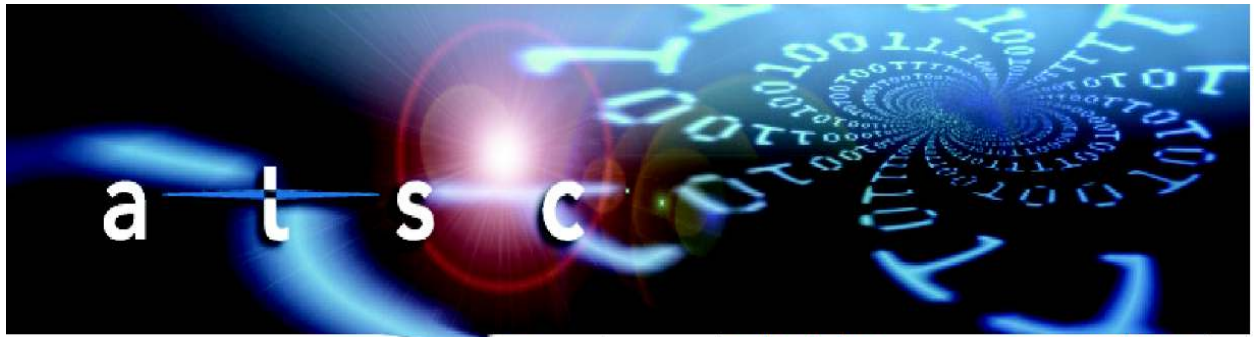

advancedtelevisionssystemscmitteeinc

Advanced Television Systems Committee, Inc.
1750 K Street, N.W., Suite 1200
Washington, D.C. 20006