



The Broadcast[®]
Standards
Association



ATSC Recommended Practice: ATSC 3.0 PHY Lab Performance Test Plan

A/325:2026-04

14 April 2026

ATSC[®], the Broadcast Standards Association[®], is an international, non-profit organization developing voluntary standards and recommended practices for broadcast television and multimedia data distribution. ATSC member organizations represent the broadcast, professional equipment, motion picture, consumer electronics, computer, cable, satellite, and semiconductor industries. ATSC also develops implementation strategies and supports educational activities on ATSC standards. ATSC was formed in 1983 by the member organizations of the Joint Committee on Inter-society Coordination (JCIC): the Consumer Technology Association (CTA), the Institute of Electrical and Electronics Engineers (IEEE), the National Association of Broadcasters (NAB), the Internet & Television Association (NCTA), and the Society of Motion Picture and Television Engineers (SMPTE). For more information visit www.atsc.org.

© Copyright 2026 ATSC. All rights reserved.

Note: The user's attention is called to the possibility that compliance with this Recommended Practice may require use of an invention covered by patent rights. By publication of this document, no position is taken with respect to the validity of this claim or of any patent rights in connection therewith. One or more patent holders have, however, filed a statement regarding the terms on which such patent holder(s) may be willing to grant a license under these rights to individuals or entities desiring to obtain such a license. Details may be obtained from the ATSC Secretary and the patent holder.

Implementers with feedback, comments, or potential bug reports relating to this document may contact ATSC at <https://www.atsc.org/feedback/>.

Revision History

Version	Date
A/325:2017 Recommended Practice approved	5 May 2017
A/325:2018 approved	10 December 2018
Corrigendum No. 1 approved	28 October 2020
A/325:2022-03 (references to ATSC documents updated)	31 March 2022
A/325:2023-03 (references to ATSC documents updated)	28 March 2023
Corrigendum No. 1 approved	21 April 2023
A/325:2024-04 (references to ATSC documents updated)	3 April 2024
A/325:2025-07 (references to ATSC documents updated)	17 July 2025
A/325:2026-04 (references to ATSC documents updated)	14 April 2026

Table of Contents

1. SCOPE	7
1.1 Introduction and Background	7
1.2 Organization	7
2. REFERENCES	7
2.1 Informative References	7
3. DEFINITION OF TERMS	8
3.1 Compliance Notation	8
3.2 Acronyms and Abbreviation	8
4. INTRODUCTION	10
5. LAB PERFORMANCE TESTS	11
5.1 Lab Performance - Demodulator	11
5.1.1 Frequency Pull-in range	13
5.1.2 Modes of Configuration	14
5.1.3 Impairment Paths	42
5.1.4 Peak-to-Average Power Ratio	48
5.1.5 Single Frequency Network (SFN)	49
5.2 Lab Performance – System	52
5.2.1 AGC Dynamic Range	53
5.2.2 Frequency Range	55
5.2.3 Phase Noise	56
5.2.4 Impulse Noise	57
5.2.5 AWGN with Power Levels: Weak, Moderate, Strong	62
5.2.6 Interference with ACI, CCI, etc.	62
ANNEX A : RF CHANNEL PROFILE DESCRIPTIONS	66
A.1 Two Path Ensemble	66
A.2 Brazil Ensembles	66
A.2.1 Brazil E	66
A.2.2 Brazil C Modified	66
A.3 Communications Research Centre Canada (CRC) Ensembles	67
A.3.1 CRC Modified #1 (5 Hz)	67
A.3.2 CRC Modified #2 (5 Hz)	67
A.3.3 CRC Modified #3 (5 Hz)	67
A.4 Rayleigh Ensembles	67
A.4.1 Single Path Rayleigh	68
A.5 Typical Urban Ensemble	68
A.5.1 TU-6	68
A.6 Handheld Ensembles	68
A.6.1 Portable Indoor Ensemble	68
A.6.2 Portable Outdoor Ensemble	69
A.7 Pedestrian Ensembles	69
A.7.1 Pedestrian A Ensemble	69
A.7.2 Pedestrian B Ensemble	69
A.8 Vehicular Ensembles	69

A.8.1	Vehicular A Ensemble	69
A.8.2	Vehicular B Ensemble	70
A.9	ATSC Ensembles	70
A.9.1	ATSC R1 Static Dynamic Echo Ensemble	70
A.9.2	ATSC R2.1 Multiple Dynamic Echo Ensemble	70
A.9.3	ATSC R2.2 Multiple Dynamic Echo Ensemble	70
ANNEX B EXAMPLE CONFIGURATION SETTINGS		71
B.1	Device Under Test Configurations	71

Index of Figures and Tables

Figure 4.1 Example system diagram.	10
Figure 5.1 Channel impairment test setup.	11
Figure 5.2 Physical Layer packet lengths.	12
Figure 5.3 Peak-to-Average Power Ratio test setup	49
Figure 5.4 SFN test setup.	50
Figure 5.5 Lab Performance system setup.	53
Figure 5.6 Impulse noise test setup.	58
Figure 5.7 Classic gated AWGN test waveform.	59
Figure 5.8 Gated squared AWGN test waveform.	60
Figure 5.9 ACI/CCI test setup.	63
Table 5.1 Frequency Pull-in Test Results	14
Table 5.2 Gaussian Channel 8K FFT Configuration Mode Test Results	15
Table 5.3 Gaussian Channel 16K FFT Configuration Mode Test Results	19
Table 5.4 Gaussian Channel 32K FFT Configuration Mode Test Results	24
Table 5.5 Rayleigh Channel 8K FFT Configuration Mode Test Results	29
Table 5.6 Rayleigh Channel 16K FFT Configuration Mode Test Results	32
Table 5.7 Rayleigh Channel 32K FFT Configuration Mode Test Results	37
Table 5.8 AWGN Channel Test Results	43
Table 5.9 TU-6 Channel Test Results	43
Table 5.10 Single Path Rayleigh Channel Test Results	44
Table 5.11 Pedestrian B Channel Test Results	45
Table 5.12 Single 0 dB Echo Channel Test Results	46
Table 5.13 Long Multipath Channel Test Results	46
Table 5.14 Single Dynamic Echo Channel Test Results	47
Table 5.15 Multiple Dynamic Echo Channel Test Results	48
Table 5.16 Peak-to-Average Power Ratio Results	49
Table 5.17 SFN 2-path Channel Results	51
Table 5.18 SFN Channel Test Results	52
Table 5.19 AGC Dynamic Range Test Results	55
Table 5.20 Channel Band Frequencies for the United States	55
Table 5.21 Frequency Range Test Results	56
Table 5.22 Phase Noise Results	57
Table 5.23 Impulse Noise Pulse Patterns	59
Table 5.24 Impulse Noise Test Results	61
Table 5.25 AWGN Channel Test Results	62
Table 5.26 Digital ACI Test Results	64

Table 5.27 LTE ACI Test Results	64
Table 5.28 Digital CCI Test Results	65
Table A.1.1 Two Path Ensemble	66
Table A.2.1 Brazil E Ensemble	66
Table A.2.2 Brazil C Modified Ensemble	66
Table A.3.1 CRC Modified #1 (5 Hz)	67
Table A.3.2 CRC Modified #2 (5 Hz)	67
Table A.3.3 CRC Modified #3 (5 Hz)	67
Table A.4.1 Single Path Rayleigh	68
Table A.5.1 TU-6 Ensemble	68
Table A.6.1 Portable Indoor Ensemble	68
Table A.6.2 Portable Outdoor Ensemble	69
Table A.7.1 Pedestrian A Ensemble	69
Table A.7.2 Pedestrian B Ensemble	69
Table A.8.1 Vehicular A Ensemble	69
Table A.8.2 Vehicular B Ensemble	70
Table A.9.1 ATSC R1 Ensemble	70
Table A.9.2 ATSC R2.1 Ensemble	70
Table A.9.3 ATSC R2.2 Ensemble	70
Table B.1.1 Example DUT Configurations	71

ATSC Recommended Practice: ATSC 3.0 PHY Lab Performance Test Plan

1. SCOPE

This document summarizes processes used to test the RF performance of ATSC 3.0 in a laboratory environment. The intention of this document is to describe test processes and test results for manufacturers attempting to verify RF performance of their receiver's physical layer designs. This document should be used by manufacturers to ensure their lab testing is conducted consistently and can be independently verified by the ATSC 3.0 development team.

Following is a listing of all tests recommended to verify the performance of ATSC 3.0 receiver designs. Each test process includes a diagram of the interconnection required to perform the test, the parameters under which the connecting devices are configured, and the expected results generated by a device under test when connected as demonstrated herein.

1.1 Introduction and Background

The physical layer has many configurations and some strenuous tests will only use selected configurations. Results of these tests will indicate realistic performance levels of devices in the market, and will also aid broadcasters in their network planning efforts.

Device Under Test will also have different device types, ranging from experimental implementations to fully integrated units with display screens, and can include both professional and consumer products. Tests in this document should accommodate all device types, and thresholds can be determined with different measurements of bits or packets or observable errors in motion pictures.

1.2 Organization

This document is organized as follows:

- Section 1 – Outlines the scope of this document and provides a general introduction.
- Section 2 – Lists references and applicable documents.
- Section 3 – Provides a definition of terms, acronyms, and abbreviations for this document.
- Section 4 – Introduction to Lab Performance Testing System
- Section 5 – Lab Performance test description, technique and results
- Annex A – RF Channel Profiles
- Annex B – Device Under Test Configurations

2. REFERENCES

All referenced documents are subject to revision. Users of this Recommended Practice are cautioned that newer editions might or might not be compatible.

2.1 Informative References

The following documents contain information that may be helpful in applying this Recommended Practice.

- [1] IEEE: "Use of the International Systems of Units (SI): The Modern Metric System," Doc. SI 10, Institute of Electrical and Electronics Engineers, New York, NY.

- [2] FCC/OET, “Measurements of LTE into DTV Interference,” FCC Office of Engineering and Technology, Report TA-2014-01, January 2014.
- [3] Nordig, “NorDig-Unified_Test_plan_ver_2.5.0,” Nordig Organization, January 2016.
- [4] ATSC: “ATSC System Discovery and Signaling,” Doc. A/321:2026-04, ATSC, Washington, DC, 14 April 2026.
- [5] ATSC: “ATSC Standard: Physical Layer Protocol,” Doc. A/322:2026-04, ATSC, Washington, DC, 14 April 2026.
- [6] ITU-R: “Measurements of protection ratios and overload thresholds for broadcast TV receivers,” Report ITU-R BT.2215-6, February 2016.
- [7] J. Lago-Fernandez and J. Salter, “Modelling impulsive interference in DVB-T – statistical analysis, test waveforms and receiver performance,” *EBU Technical Review*, July 2004.
- [8] NIST: “Calibration Uncertainty for the NIST PM/AM Noise Standards,” Special Publication 250-90, National Institute of Standards and Technology, U.S. Department of Commerce, Boulder, Colorado, July 2012.
- [9] FCC/OET-74, “Longley-Rice Methodology for Predicting Inter-Service Interference to Broadcast Television from Mobile Wireless Broadband Services in the UHF Band,” FCC Office of Engineering and Technology, 26 October 2015.
- [10] ATSC: “ATSC Recommended Practice: Receiver Performance Guidelines,” Doc. A/74:2010, ATSC, Washington, DC, 7 April 2010.

3. DEFINITION OF TERMS

With respect to definition of terms, abbreviations, and units, the practice of the Institute of Electrical and Electronics Engineers (IEEE) as outlined in the Institute’s published standards [1] is used. Where an abbreviation is not covered by IEEE practice or industry practice differs from IEEE practice, the abbreviation in question will be described in Section 3.2 of this document.

3.1 Compliance Notation

This section defines compliance terms for use by this document:

should – This word indicates that a certain course of action is preferred but not necessarily required.

should not – This phrase means a certain possibility or course of action is undesirable but not prohibited.

3.2 Acronyms and Abbreviation

The following acronyms and abbreviations are used within this document.

A/D	Analog to Digital
ACATS	Advisory Committee on Advanced Television Service
ACI	Adjacent Channel Interference
AGC	Automatic Gain Control
ALC	Asynchronous Layered Coding
ALP	ATSC 3.0 Link-Layer Protocol
AWGN	Additive White Gaussian Noise
BCH	Bose-Chaudhuri-Hocquenghem
BER	Bit Error Rate

BS	Bootstrap
BSR	Baseband Sample Rate
BTC	Broadcast Test Center
C/I	Carrier to Interference ratio
C/N	Carrier to Noise
CCI	Co-Channel Interference
CFO	Center Frequency Offset
CRC	Cyclic Redundancy Check
CTI	Convolutional Time Interleaver
D/A	Digital to Analog
D/U	Desired / Undesired
dB	decibel
dBm	decibels referenced to 1 milliwatt
DUT	Device Under Test
EMI	Electromagnetic Interference
ESR₅	Erroneous-Second Ratio
FCC	Federal Communications Commission
FEC	Forward Error Correction
FFT	Fast Fourier Transform
GI	Guard Interval
HTI	Hybrid Time Interleaver
Hz	Hertz
I/Q	In-phase / Quadrature
IF	Intermediate Frequency
IP	Internet Protocol
kHz	kilo Hertz
LAPR	Licensed to Average Power Ratio
LCT	Layered Coding Transport
LDM	Layered Division Multiplexing
LDPC	Low Density Parity Check
LED	Light Emitting Diode
LTE	Long Term Evolution
MHz	Mega Hertz
MISO	Multiple Input Single Output
μsec	microsecond
N/A	Not Applicable
NoC	Number of Carriers
nsec	nanosecond
NUC	Non Uniform Constellation
OFDM	Orthogonal Frequency Division Multiplexing
PC	Personal Computer
PER	Packet Error Rate

PHY	Physical Layer
PLP	Physical Layer Pipe
PRBS	Pseudo-Random Bit Sequence
Pre	Preamble
QAM	Quadrature Amplitude Modulation
QPSK	Quadrature Phase Shift Keying
RF	Radio Frequency
RMS	Root Mean Square
ROUTE	Real-Time Object Delivery over Unidirectional Transport
RTP	Real Time Protocol
Rx	Receiver
SFN	Single Frequency Network
SISO	Single Input Single Output
SNR	Signal to Noise Ratio
SP	Scattered Pilot
SPLP	Single Physical Layer Pipe
STL	Studio Transmitter Link
TCP	Transmission Control Protocol
TDCFS	Time Diversity Code Filter Set
TDM	Time Division Multiplexing
TI	Time Interleaver
TOV	Threshold of Visibility
Tx	Transmitter
UDP	User Datagram Protocol
UHF	Ultra High Frequency
VHF	Very High Frequency

4. INTRODUCTION

Lab tests attempt to encompass as much real world environment as possible. To debug possible issues in the receiver, separate pieces of tuner and demodulator are tested individually. An example overview of the test system setup is shown in Figure 4.1.

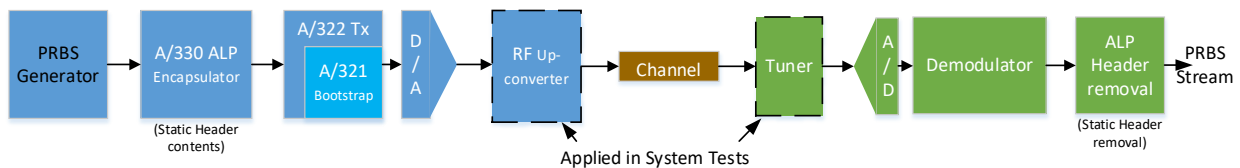

Figure 4.1 Example system diagram.

Section 5.1 focuses on demodulator performance only (i.e., no transmitter up-converter or receiver tuner). Section 5.2 focuses on the entire system performance that includes a transmitter RF up-converter and a receiver tuner. Tests are separated between the two test setups based on relevance of results for each specific test. Receiver demodulators will have different forms, and

outputs may or may not include ALP packets. Procedures for testing are general enough to account for these differences, and results tables can be filled in for a variety of demodulator types.

5. LAB PERFORMANCE TESTS

Lab performance is tested with two methods, one without a tuner and one with a tuner. Lab tests without a tuner are labeled Lab Performance – Demodulator to exercise the demodulation of the waveform and lab tests with a tuner are labeled Lab Performance – System to account for both tuner and demodulator effects.

5.1 Lab Performance - Demodulator

General Lab setup for channel impairment testing without tuners may be found below in Figure 5.1. No transmitter upconverter or receiver tuner is intended to be used but rather an IF signal is used to perform this test. These tests may also be used with a tuner using RF channel amplitude of -53 dBm.

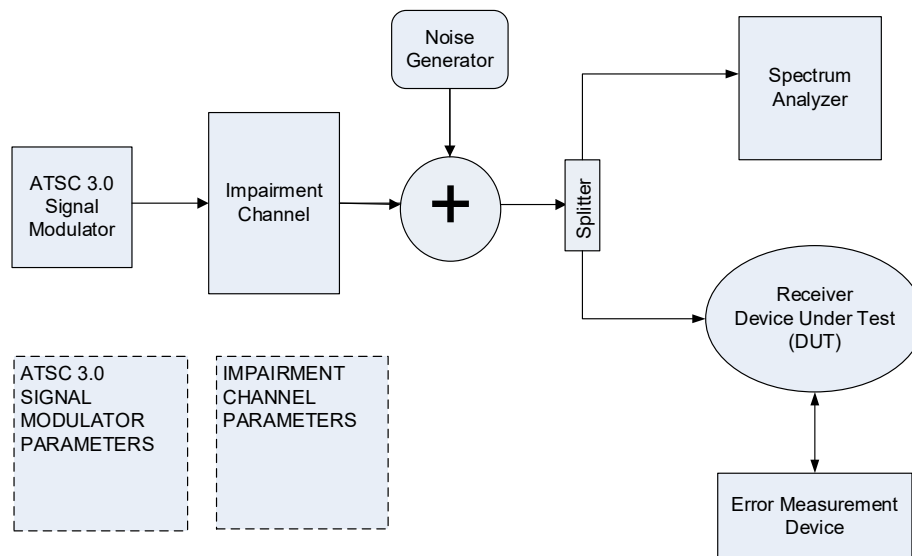

Figure 5.1 Channel impairment test setup.

Test procedures have 3 steps: 1) setup, 2) measurement technique, and 3) results reporting. The Device Under Test (DUT) will be probed at the FEC outer decoder (BCH / CRC) output; i.e., ALP packets, and appropriate internal registers that may exist.

Moderate signal level should be used that is 20 to 30 dB above the threshold of visibility of a Rx. This provides more D/U range for tests to be conducted without running into hardware limitations. A value of -53 dBm is typically used elsewhere, and will be used here as well for power levels of the desired signals.

Tests should be performed objectively by observing Bit Error Rate (BER) using PRBS test sequences or Packet Error Rate (PER) for implementation of C/N measurements or Erroneous-Second Ratio (ESR₅) for quality of service at the output of the receiver, depending on the device type. ESR₅ is defined in [6]. Zero errors is a useful metric for determining demodulator performance. Zero errors is defined as all measured samples within a defined time window

resulting in a BER or PER below a defined negligible threshold. See footnote number 2 for further threshold definition.

The transmitter has an interface at the ALP construction point and there is likely a receiver exit point with ALP packets. This may make for an easy access test point. Datagrams of up to 1500 bytes can be long enough to not have difference between BER and PER per the criteria being tested.

PHY has FEC frames which may produce BER, but at the transport layer there are only packets. If packet errors occur in packet header, the entire packet will be lost. If packet errors occur in data, there is a corrupted packet. (lost packets vs. packet errors). Packet lengths and relation to frames at important steps of physical layer frame construction are given in Figure 5.2.

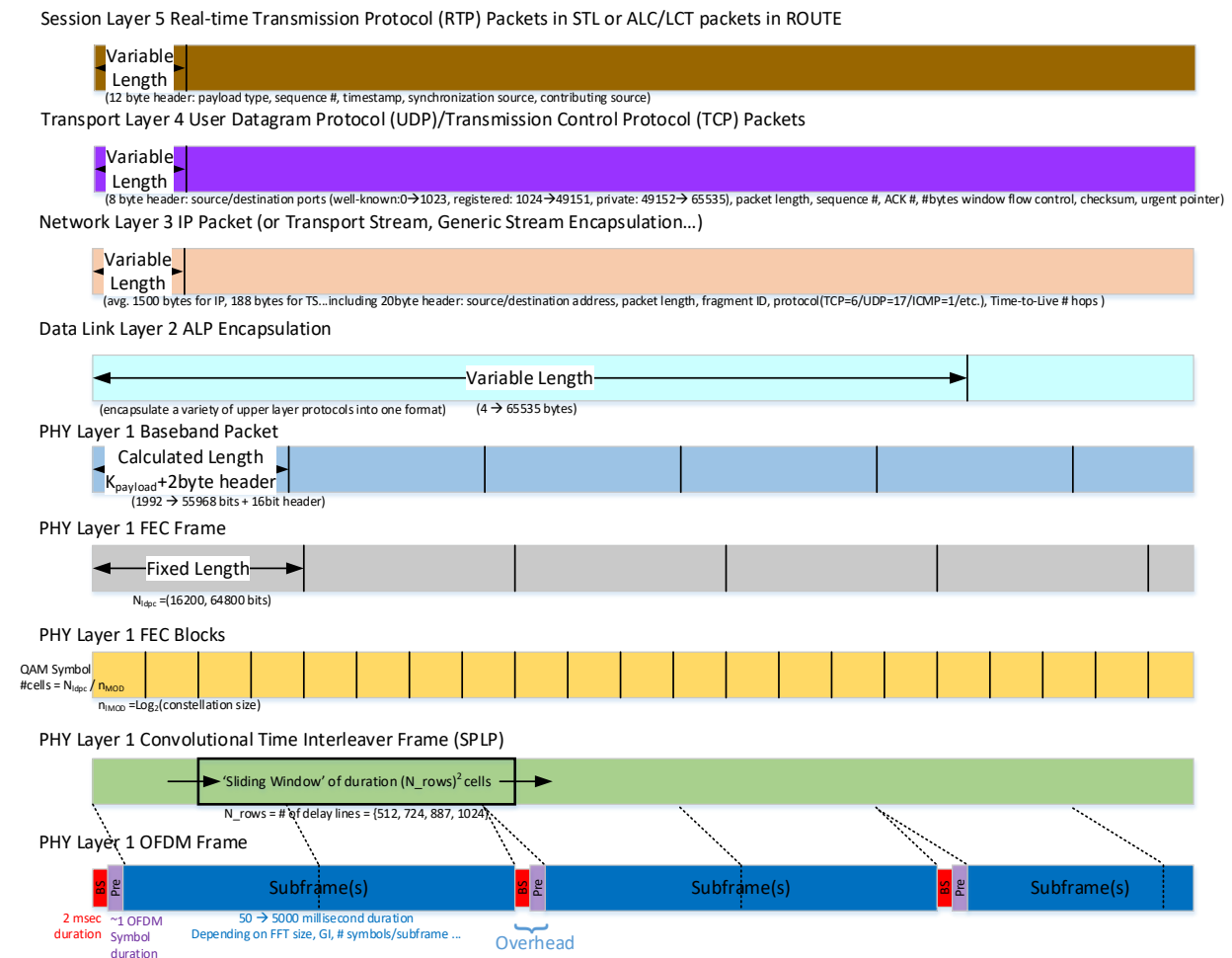

Figure 5.2 Physical Layer packet lengths.

Physical layer OFDM frames have bootstrap (BS) and preamble (Pre) symbols as overhead to the data symbols that contain multiplexed time interleaved QAM symbol cells. Errors are equally likely to occur in the overhead and subframe(s) sections. If an error occurs in any of the four bootstrap symbols, the entire frame (all blue subframes after that bootstrap) may be lost. If an error occurs in the (usually) one preamble symbol, the subframe data may or may not be affected, depending on severity of the echo or signal loss.

Bootstrap symbols are designed to be the most robust part of the physical layer transmission and show error resiliency below -6 dB C/N in Rayleigh channels. To affect those bootstrap symbols, signal energy loss must be lower than 4x the environment noise level. Preamble symbols are less robust than bootstrap symbols but more robust than data payload symbols. There are several selections of robustness levels for preamble symbols. There are also 3 FFT sizes combined with various combinations of different guard intervals and pilot patterns yielding 160 cases of preamble operation. SNR data threshold is estimated to range from around -6 dB to 25 dB for those preamble symbols in Rayleigh channels. To affect the preamble symbols signal energy loss must be greater than the estimated SNR threshold for that mode selected. Data payload symbols have the largest range of SNR depending on the mode of operation (i.e., the selected FEC and modulation parameters).

In summary, there are 4 very robust bootstrap symbols, (usually) 1 robust preamble symbol and a large number of data payload symbols. Symbol errors are statistically equally likely to occur in each of them, but the effect depends on the robustness of that affected symbol. Data symbol loss will be affected first when testing echoes of a certain power as they are the least robust. That data symbol loss translates to ALP packet (data and header) loss. ALP headers contain information regarding packet type and length and whether there is segmentation / concatenation. ALP header contents are expected to be static; i.e., they are not likely to change during Lab Performance testing, and packet lengths and types can therefore be expected to be a fixed size for the length of each test. With constant expected data in ALP headers, ALP packets may be used for Lab Performance testing as Devices Under Test (DUT) may use expected settings.

Procedures for each test are general enough to apply to all device types (e.g., hardware prototypes, chips, devices, integrated products with video screens only) and results have respective metrics to apply to different scopes of devices.

ATSC 3.0 Signal Modulator Parameters are a list of configuration settings from [4] which are useful for lab testing. There are many settings and only a select few are chosen for lab performance testing to satisfy configurations of interest to broadcasters as well as testing enough settings for confidence. A list of those settings used is given in Appendix B.1.

Measurement testing bandwidths use channel bandwidths. ATSC 3.0 offers different signal bandwidths with certain number of carriers and other parameter choices, so to compare performance across many parameter selections, channel bandwidth (e.g., 6 MHz) should be used.

5.1.1 Frequency Pull-in range

5.1.1.1 Frequency Pull-in Description

For each channel bandwidth, center frequency offsets from tuners need to be accounted for in demodulators. This test measures the maximum frequency offset tolerated by the DUT.

5.1.1.2 Frequency Pull-in Measurement Technique

Steps:

- 1) Set up test equipment as shown in Figure 5.1 with no Impairment Channel. (clean channel with no ghost or added noise).
- 2) Use ATSC 3.0 Modulator parameters of Configuration 1 in Annex B.1.
- 3) Set received input signal strength to -53 dBm RF channel input, or appropriate IF signal amplitude for DUT (verify with Spectrum Analyzer).
- 4) Start with DUT intermediate frequency pull-in with no offset.
- 5) Tune DUT to signal and verify clean reception.

- 6) Increase frequency offset until errors appear in the data stream¹.
- 7) Log results of total clean data (1 less step than threshold point) in Table 5.1.
- 8) Repeat test with increasing frequency offsets until L1-Detail, L1-Basic and the Bootstrap reach error threshold.

5.1.1.3 Frequency Pull-in Results

Table 5.1 Frequency Pull-in Test Results

Parameter	Measured Channel Power	Frequency offset
Desired Signal Level	-53 dBm or IF level	
Frequency offset at stream error threshold ²		
Frequency offset at L1-Detail error threshold		
Frequency offset at L1-Basic error threshold		
Frequency offset at Bootstrap error threshold		

5.1.2 Modes of Configuration

5.1.2.1 Configuration Modes Description

There are many modes of operation to allow for broadcaster optimization of their channel for their market environment and business goals. Each mode should be tested to verify correct operation at the designed SNR threshold points. This test looks at Gaussian and Rayleigh channels for payload data only, not focusing on preamble or bootstrap performance. The DUT should automatically detect each configuration mode.

5.1.2.2 Configuration modes Measurement Technique

Steps:

- 1) Set up test equipment as shown in Figure 5.1 with no Impairment Channel. (clean channel with no ghost or added noise).
- 2) Use ATSC 3.0 Modulator with 6 MHz bandwidth and parameters as indicated in Table 5.2 through Table 5.4 with scattered pilot patterns indicated by D_x with D_y of 4 and a single PLP configuration.
- 3) Set received input signal strength to -53 dBm RF channel input, or appropriate IF signal amplitude for DUT. (Verify with Spectrum Analyzer.)
- 4) Tune DUT to signal and verify clean reception.

¹ Errors may be measured by different means depending on the Error Measurement Device used in Figure 5.1.

ALP analysis enables bit error measurements, but only for the stream data.

A PC connection may interrogate receiver registers to determine BCH or LDPC failures for the data stream.

A PC may interrogate internal registers for CRC errors in L1-Detail and L1-Basic.

A PC may interrogate internal registers for CFO lock for the Bootstrap.

For a black box approach, the video or audio can be monitored for errors as a check on the stream data. A moving zone plate for the video would provide the most sensitive measurement due to its resiliency against video error concealment.

² Threshold may be defined as clean reception where no errors are present in at least two of three consecutive 20 second intervals.

- 5) Set Noise Generator output power to -90 dBm (with Gaussian noise distribution).
- 6) Determine the noise power setting at which errors begin in the data stream, a Threshold of Visibility (TOV), with a resolution of 0.1dB. One method of accomplishing this would be to use a large step size in the noise power to identify the waterfall region and then switch to smaller step sizes to identify the exact TOV point.
- 7) Remove modulated signal and measure the noise power in the channel.
- 8) Calculate the resulting C/N and log results in Table 5.2 through Table 5.4.
- 9) Repeat test with a Single Path Rayleigh channel model as in Appendix A.4.1 in Step 1 and log in Table 5.5 through Table 5.7.

5.1.2.3 Configuration Modes Results

This table includes the modes as outlined in Tables 6.12 and 6.13 of [4]. Shaded entries are not mandatory modes per [4].

Table 5.2 Gaussian Channel 8K FFT Configuration Mode Test Results

FFT Size: 8K			GI: 192 samples (D _x =16)	GI: 384 samples (D _x =8)	GI: 512 samples (D _x =6)	GI: 768 samples (D _x =4)	GI: 1024 samples (D _x =3)	GI: 1536 samples (D _x =4)	GI: 2048 samples (D _x =3)
Mod	Code-length	Code rate	Calculated C/N	Calculated C/N	Calculated C/N	Calculated C/N	Calculated C/N	Calculated C/N	Calculated C/N
QPSK	64800	2/15							
		3/15							
		4/15							
		5/15							
		6/15							
		7/15							
		8/15							
		9/15							
		10/15							
		11/15							
		12/15							
		13/15							
		QPSK	16200	2/15					
3/15									
4/15									
5/15									
6/15									
7/15									
8/15									
9/15									
10/15									
11/15									
12/15									
13/15									
16 QAM	64800			2/15					
		3/15							
		4/15							

FFT Size: 8K			GI: 192 samples (D _x =16)	GI: 384 samples (D _x =8)	GI: 512 samples (D _x =6)	GI: 768 samples (D _x =4)	GI: 1024 samples (D _x =3)	GI: 1536 samples (D _x =4)	GI: 2048 samples (D _x =3)
Mod	Code-length	Code rate	Calculated C/N	Calculated C/N	Calculated C/N	Calculated C/N	Calculated C/N	Calculated C/N	Calculated C/N
		5/15							
		6/15							
		7/15							
		8/15							
		9/15							
		10/15							
		11/15							
		12/15							
		13/15							
16 QAM	16200	2/15							
		3/15							
		4/15							
		5/15							
		6/15							
		7/15							
		8/15							
		9/15							
		10/15							
		11/15							
		12/15							
		13/15							
64 QAM	64800	2/15							
		3/15							
		4/15							
		5/15							
		6/15							
		7/15							
		8/15							
		9/15							
		10/15							
		11/15							
		12/15							
		13/15							
64 QAM	16200	2/15							
		3/15							
		4/15							
		5/15							
		6/15							
		7/15							
		8/15							
		9/15							

FFT Size: 8K			GI: 192 samples (D _x =16)	GI: 384 samples (D _x =8)	GI: 512 samples (D _x =6)	GI: 768 samples (D _x =4)	GI: 1024 samples (D _x =3)	GI: 1536 samples (D _x =4)	GI: 2048 samples (D _x =3)
Mod	Code-length	Code rate	Calculated C/N	Calculated C/N	Calculated C/N	Calculated C/N	Calculated C/N	Calculated C/N	Calculated C/N
		10/15							
		11/15							
		12/15							
		13/15							
256 QAM	64800	2/15							
		3/15							
		4/15							
		5/15							
		6/15							
		7/15							
		8/15							
		9/15							
		10/15							
		11/15							
		12/15							
		13/15							
256 QAM	16200	2/15							
		3/15							
		4/15							
		5/15							
		6/15							
		7/15							
		8/15							
		9/15							
		10/15							
		11/15							
		12/15							
		13/15							
1024 QAM	64800	2/15							
		3/15							
		4/15							
		5/15							
		6/15							
		7/15							
		8/15							
		9/15							
		10/15							
		11/15							
		12/15							
		13/15							

FFT Size: 8K			GI: 192 samples (D _x =16)	GI: 384 samples (D _x =8)	GI: 512 samples (D _x =6)	GI: 768 samples (D _x =4)	GI: 1024 samples (D _x =3)	GI: 1536 samples (D _x =4)	GI: 2048 samples (D _x =3)
Mod	Code-length	Code rate	Calculated C/N	Calculated C/N	Calculated C/N	Calculated C/N	Calculated C/N	Calculated C/N	Calculated C/N
4096 QAM	64800	2/15							
		3/15							
		4/15							
		5/15							
		6/15							
		7/15							
		8/15							
		9/15							
		10/15							
		11/15							
		12/15							
		13/15							

Table 5.3 Gaussian Channel 16K FFT Configuration Mode Test Results

FFT Size: 16K			GI: 192 samples (Dx=32)	GI: 384 samples (Dx=16)	GI: 512 samples (Dx=12)	GI: 768 samples (Dx=8)	GI: 1024 samples (Dx=6)	GI: 1536 samples (Dx=4)	GI: 2048 samples (Dx=3)	GI: 2432 samples (Dx=3)	GI: 3072 samples (Dx=4)	GI: 3648 samples (Dx=4)	GI: 4096 samples (Dx=3)	
Mod	Code-length	Code rate	Calculated C/N	Calculated C/N	Calculated C/N	Calculated C/N	Calculated C/N	Calculated C/N	Calculated C/N	Calculated C/N	Calculated C/N	Calculated C/N	Calculated C/N	
QPSK	64800	2/15												
		3/15												
		4/15												
		5/15												
		6/15												
		7/15												
		8/15												
		9/15												
		10/15												
		11/15												
		12/15												
		13/15												
		QPSK	16200	2/15										
3/15														
4/15														
5/15														
6/15														
7/15														
8/15														
9/15														
10/15														
11/15														
12/15														
13/15														
16 QAM	64800			2/15										
		3/15												
		4/15												

FFT Size: 16K			GI: 192 samples (D _x =32)	GI: 384 samples (D _x =16)	GI: 512 samples (D _x =12)	GI: 768 samples (D _x =8)	GI: 1024 samples (D _x =6)	GI: 1536 samples (D _x =4)	GI: 2048 samples (D _x =3)	GI: 2432 samples (D _x =3)	GI: 3072 samples (D _x =4)	GI: 3648 samples (D _x =4)	GI: 4096 samples (D _x =3)
Mod	Code-length	Code rate	Calculated C/N	Calculated C/N	Calculated C/N	Calculated C/N	Calculated C/N	Calculated C/N	Calculated C/N	Calculated C/N	Calculated C/N	Calculated C/N	Calculated C/N
		5/15											
		6/15											
		7/15											
		8/15											
		9/15											
		10/15											
		11/15											
		12/15											
		13/15											
16 QAM	16200	2/15											
		3/15											
		4/15											
		5/15											
		6/15											
		7/15											
		8/15											
		9/15											
		10/15											
		11/15											
		12/15											
		13/15											
64 QAM	64800	2/15											
		3/15											
		4/15											
		5/15											
		6/15											
		7/15											
		8/15											

FFT Size: 16K			GI: 192 samples (D _x =32)	GI: 384 samples (D _x =16)	GI: 512 samples (D _x =12)	GI: 768 samples (D _x =8)	GI: 1024 samples (D _x =6)	GI: 1536 samples (D _x =4)	GI: 2048 samples (D _x =3)	GI: 2432 samples (D _x =3)	GI: 3072 samples (D _x =4)	GI: 3648 samples (D _x =4)	GI: 4096 samples (D _x =3)
Mod	Code-length	Code rate	Calculated C/N	Calculated C/N	Calculated C/N	Calculated C/N	Calculated C/N	Calculated C/N	Calculated C/N	Calculated C/N	Calculated C/N	Calculated C/N	Calculated C/N
		9/15											
		10/15											
		11/15											
		12/15											
		13/15											
64 QAM	16200	2/15											
		3/15											
		4/15											
		5/15											
		6/15											
		7/15											
		8/15											
		9/15											
		10/15											
		11/15											
		12/15											
		13/15											
256 QAM	64800	2/15											
		3/15											
		4/15											
		5/15											
		6/15											
		7/15											
		8/15											
		9/15											
		10/15											
		11/15											
		12/15											

FFT Size: 16K			GI: 192 samples (D _x =32)	GI: 384 samples (D _x =16)	GI: 512 samples (D _x =12)	GI: 768 samples (D _x =8)	GI: 1024 samples (D _x =6)	GI: 1536 samples (D _x =4)	GI: 2048 samples (D _x =3)	GI: 2432 samples (D _x =3)	GI: 3072 samples (D _x =4)	GI: 3648 samples (D _x =4)	GI: 4096 samples (D _x =3)	
Mod	Code-length	Code rate	Calculated C/N	Calculated C/N	Calculated C/N	Calculated C/N	Calculated C/N	Calculated C/N	Calculated C/N	Calculated C/N	Calculated C/N	Calculated C/N	Calculated C/N	
		13/15												
256 QAM	16200	2/15												
		3/15												
		4/15												
		5/15												
		6/15												
		7/15												
		8/15												
		9/15												
		10/15												
		11/15												
		12/15												
		13/15												
		1024 QAM	64800	2/15										
3/15														
4/15														
5/15														
6/15														
7/15														
8/15														
9/15														
10/15														
11/15														
12/15														
13/15														
4096 QAM	64800			2/15										
		3/15												
		4/15												

FFT Size: 16K			GI: 192 samples (D _x =32)	GI: 384 samples (D _x =16)	GI: 512 samples (D _x =12)	GI: 768 samples (D _x =8)	GI: 1024 samples (D _x =6)	GI: 1536 samples (D _x =4)	GI: 2048 samples (D _x =3)	GI: 2432 samples (D _x =3)	GI: 3072 samples (D _x =4)	GI: 3648 samples (D _x =4)	GI: 4096 samples (D _x =3)
Mod	Code-length	Code rate	Calculated C/N	Calculated C/N	Calculated C/N	Calculated C/N	Calculated C/N	Calculated C/N	Calculated C/N	Calculated C/N	Calculated C/N	Calculated C/N	Calculated C/N
		5/15											
		6/15											
		7/15											
		8/15											
		9/15											
		10/15											
		11/15											
		12/15											
		13/15											

Table 5.4 Gaussian Channel 32K FFT Configuration Mode Test Results

FFT Size: 32K			GI: 192 samples (D _x =32)	GI: 384 samples (D _x =32)	GI: 512 samples (D _x =24)	GI: 768 samples (D _x =16)	GI: 1024 samples (D _x =12)	GI: 1536 samples (D _x =8)	GI: 2048 samples (D _x =6)	GI: 2432 samples (D _x =6)	GI: 3072 samples (D _x =8,3)	GI: 3648 samples (D _x =8,3)	GI: 4096 samples (D _x =3)	GI: 4864 samples (D _x =3)
Mod	Code-length	Code rate	Calculated C/N	Calculated C/N	Calculated C/N	Calculated C/N	Calculated C/N	Calculated C/N	Calculated C/N	Calculated C/N	Calculated C/N	Calculated C/N	Calculated C/N	Calculated C/N
QPSK	64800	2/15												
		3/15												
		4/15												
		5/15												
		6/15												
		7/15												
		8/15												
		9/15												
		10/15												
		11/15												
		12/15												
		13/15												
		QPSK	16200	2/15										
3/15														
4/15														
5/15														
6/15														
7/15														
8/15														
9/15														
10/15														
11/15														
12/15														
13/15														
16 QAM	64800			2/15										
		3/15												
		4/15												
		5/15												

FFT Size: 32K			GI: 192 samples (D _x =32)	GI: 384 samples (D _x =32)	GI: 512 samples (D _x =24)	GI: 768 samples (D _x =16)	GI: 1024 samples (D _x =12)	GI: 1536 samples (D _x =8)	GI: 2048 samples (D _x =6)	GI: 2432 samples (D _x =6)	GI: 3072 samples (D _x =8,3)	GI: 3648 samples (D _x =8,3)	GI: 4096 samples (D _x =3)	GI: 4864 samples (D _x =3)
Mod	Code-length	Code rate	Calculated C/N	Calculated C/N	Calculated C/N	Calculated C/N	Calculated C/N	Calculated C/N	Calculated C/N	Calculated C/N	Calculated C/N	Calculated C/N	Calculated C/N	Calculated C/N
		6/15												
		7/15												
		8/15												
		9/15												
		10/15												
		11/15												
		12/15												
		13/15												
16 QAM	16200	2/15												
		3/15												
		4/15												
		5/15												
		6/15												
		7/15												
		8/15												
		9/15												
		10/15												
		11/15												
		12/15												
		13/15												
64 QAM	64800	2/15												
		3/15												
		4/15												
		5/15												
		6/15												
		7/15												
		8/15												
		9/15												

FFT Size: 32K			GI: 192 samples (D _x =32)	GI: 384 samples (D _x =32)	GI: 512 samples (D _x =24)	GI: 768 samples (D _x =16)	GI: 1024 samples (D _x =12)	GI: 1536 samples (D _x =8)	GI: 2048 samples (D _x =6)	GI: 2432 samples (D _x =6)	GI: 3072 samples (D _x =8,3)	GI: 3648 samples (D _x =8,3)	GI: 4096 samples (D _x =3)	GI: 4864 samples (D _x =3)
Mod	Code-length	Code rate	Calculated C/N	Calculated C/N	Calculated C/N	Calculated C/N	Calculated C/N	Calculated C/N	Calculated C/N	Calculated C/N	Calculated C/N	Calculated C/N	Calculated C/N	Calculated C/N
		10/15												
		11/15												
		12/15												
		13/15												
64 QAM	16200	2/15												
		3/15												
		4/15												
		5/15												
		6/15												
		7/15												
		8/15												
		9/15												
		10/15												
		11/15												
		12/15												
		13/15												
256 QAM	64800	2/15												
		3/15												
		4/15												
		5/15												
		6/15												
		7/15												
		8/15												
		9/15												
		10/15												
		11/15												
		12/15												
		13/15												

FFT Size: 32K			GI: 192 samples (D _x =32)	GI: 384 samples (D _x =32)	GI: 512 samples (D _x =24)	GI: 768 samples (D _x =16)	GI: 1024 samples (D _x =12)	GI: 1536 samples (D _x =8)	GI: 2048 samples (D _x =6)	GI: 2432 samples (D _x =6)	GI: 3072 samples (D _x =8,3)	GI: 3648 samples (D _x =8,3)	GI: 4096 samples (D _x =3)	GI: 4864 samples (D _x =3)
Mod	Code-length	Code rate	Calculated C/N	Calculated C/N	Calculated C/N	Calculated C/N	Calculated C/N	Calculated C/N	Calculated C/N	Calculated C/N	Calculated C/N	Calculated C/N	Calculated C/N	Calculated C/N
256 QAM	16200	2/15												
		3/15												
		4/15												
		5/15												
		6/15												
		7/15												
		8/15												
		9/15												
		10/15												
		11/15												
		12/15												
		13/15												
		1024 QAM	64800	2/15										
3/15														
4/15														
5/15														
6/15														
7/15														
8/15														
9/15														
10/15														
11/15														
12/15														
13/15														
4096 QAM	64800			2/15										
		3/15												
		4/15												
		5/15												

FFT Size: 32K			GI: 192 samples (D _x =32)	GI: 384 samples (D _x =32)	GI: 512 samples (D _x =24)	GI: 768 samples (D _x =16)	GI: 1024 samples (D _x =12)	GI: 1536 samples (D _x =8)	GI: 2048 samples (D _x =6)	GI: 2432 samples (D _x =6)	GI: 3072 samples (D _x =8,3)	GI: 3648 samples (D _x =8,3)	GI: 4096 samples (D _x =3)	GI: 4864 samples (D _x =3)
Mod	Code-length	Code rate	Calculated C/N	Calculated C/N	Calculated C/N	Calculated C/N	Calculated C/N	Calculated C/N	Calculated C/N	Calculated C/N	Calculated C/N	Calculated C/N	Calculated C/N	Calculated C/N
		6/15												
		7/15												
		8/15												
		9/15												
		10/15												
		11/15												
		12/15												
		13/15												

Table 5.5 Rayleigh Channel 8K FFT Configuration Mode Test Results

FFT Size: 8K			GI: 192 samples (D _x =16)	GI: 384 samples (D _x =8)	GI: 512 samples (D _x =6)	GI: 768 samples (D _x =4)	GI: 1024 samples (D _x =3)	GI: 1536 samples (D _x =4)	GI: 2048 samples (D _x =3)
Mod	Code-length	Code rate	Calculated C/N	Calculated C/N	Calculated C/N	Calculated C/N	Calculated C/N	Calculated C/N	Calculated C/N
QPSK	64800	2/15							
		3/15							
		4/15							
		5/15							
		6/15							
		7/15							
		8/15							
		9/15							
		10/15							
		11/15							
		12/15							
		13/15							
		QPSK	16200	2/15					
3/15									
4/15									
5/15									
6/15									
7/15									
8/15									
9/15									
10/15									
11/15									
12/15									
13/15									
16 QAM	64800			2/15					
		3/15							
		4/15							
		5/15							
		6/15							
		7/15							
		8/15							
		9/15							
		10/15							
		11/15							
		12/15							
		13/15							
		16 QAM	16200	2/15					
3/15									
4/15									

FFT Size: 8K			GI: 192 samples (D _x =16)	GI: 384 samples (D _x =8)	GI: 512 samples (D _x =6)	GI: 768 samples (D _x =4)	GI: 1024 samples (D _x =3)	GI: 1536 samples (D _x =4)	GI: 2048 samples (D _x =3)
Mod	Code-length	Code rate	Calculated C/N	Calculated C/N	Calculated C/N	Calculated C/N	Calculated C/N	Calculated C/N	Calculated C/N
		5/15							
		6/15							
		7/15							
		8/15							
		9/15							
		10/15							
		11/15							
		12/15							
		13/15							
64 QAM	64800	2/15							
		3/15							
		4/15							
		5/15							
		6/15							
		7/15							
		8/15							
		9/15							
		10/15							
		11/15							
		12/15							
		13/15							
64 QAM	16200	2/15							
		3/15							
		4/15							
		5/15							
		6/15							
		7/15							
		8/15							
		9/15							
		10/15							
		11/15							
		12/15							
		13/15							
256 QAM	64800	2/15							
		3/15							
		4/15							
		5/15							
		6/15							
		7/15							
		8/15							
		9/15							

FFT Size: 8K			GI: 192 samples (D _x =16)	GI: 384 samples (D _x =8)	GI: 512 samples (D _x =6)	GI: 768 samples (D _x =4)	GI: 1024 samples (D _x =3)	GI: 1536 samples (D _x =4)	GI: 2048 samples (D _x =3)
Mod	Code-length	Code rate	Calculated C/N	Calculated C/N	Calculated C/N	Calculated C/N	Calculated C/N	Calculated C/N	Calculated C/N
		10/15							
		11/15							
		12/15							
		13/15							
256 QAM	16200	2/15							
		3/15							
		4/15							
		5/15							
		6/15							
		7/15							
		8/15							
		9/15							
		10/15							
		11/15							
		12/15							
		13/15							
1024 QAM	64800	2/15							
		3/15							
		4/15							
		5/15							
		6/15							
		7/15							
		8/15							
		9/15							
		10/15							
		11/15							
		12/15							
		13/15							
4096 QAM	64800	2/15							
		3/15							
		4/15							
		5/15							
		6/15							
		7/15							
		8/15							
		9/15							
		10/15							
		11/15							
		12/15							
		13/15							

Table 5.6 Rayleigh Channel 16K FFT Configuration Mode Test Results

FFT Size: 16K			GI: 192 samples (D _x =32)	GI: 384 samples (D _x =16)	GI: 512 samples (D _x =12)	GI: 768 samples (D _x =8)	GI: 1024 samples (D _x =6)	GI: 1536 samples (D _x =4)	GI: 2048 samples (D _x =3)	GI: 2432 samples (D _x =3)	GI: 3072 samples (D _x =4)	GI: 3648 samples (D _x =4)	GI: 4096 samples (D _x =3)
Mod	Code-length	Code rate	Calculated C/N	Calculated C/N	Calculated C/N	Calculated C/N	Calculated C/N	Calculated C/N	Calculated C/N	Calculated C/N	Calculated C/N	Calculated C/N	Calculated C/N
QPSK	64800	2/15											
		3/15											
		4/15											
		5/15											
		6/15											
		7/15											
		8/15											
		9/15											
		10/15											
		11/15											
		12/15											
		13/15											
		QPSK	16200	2/15									
3/15													
4/15													
5/15													
6/15													
7/15													
8/15													
9/15													
10/15													
11/15													
12/15													
13/15													
16 QAM	64800			2/15									
		3/15											
		4/15											

FFT Size: 16K			GI: 192 samples (D _x =32)	GI: 384 samples (D _x =16)	GI: 512 samples (D _x =12)	GI: 768 samples (D _x =8)	GI: 1024 samples (D _x =6)	GI: 1536 samples (D _x =4)	GI: 2048 samples (D _x =3)	GI: 2432 samples (D _x =3)	GI: 3072 samples (D _x =4)	GI: 3648 samples (D _x =4)	GI: 4096 samples (D _x =3)
Mod	Code-length	Code rate	Calculated C/N	Calculated C/N	Calculated C/N	Calculated C/N	Calculated C/N	Calculated C/N	Calculated C/N	Calculated C/N	Calculated C/N	Calculated C/N	Calculated C/N
		5/15											
		6/15											
		7/15											
		8/15											
		9/15											
		10/15											
		11/15											
		12/15											
		13/15											
16 QAM	16200	2/15											
		3/15											
		4/15											
		5/15											
		6/15											
		7/15											
		8/15											
		9/15											
		10/15											
		11/15											
		12/15											
		13/15											
64 QAM	64800	2/15											
		3/15											
		4/15											
		5/15											
		6/15											
		7/15											
		8/15											

FFT Size: 16K			GI: 192 samples (D _x =32)	GI: 384 samples (D _x =16)	GI: 512 samples (D _x =12)	GI: 768 samples (D _x =8)	GI: 1024 samples (D _x =6)	GI: 1536 samples (D _x =4)	GI: 2048 samples (D _x =3)	GI: 2432 samples (D _x =3)	GI: 3072 samples (D _x =4)	GI: 3648 samples (D _x =4)	GI: 4096 samples (D _x =3)
Mod	Code-length	Code rate	Calculated C/N	Calculated C/N	Calculated C/N	Calculated C/N	Calculated C/N	Calculated C/N	Calculated C/N	Calculated C/N	Calculated C/N	Calculated C/N	Calculated C/N
		9/15											
		10/15											
		11/15											
		12/15											
		13/15											
64 QAM	16200	2/15											
		3/15											
		4/15											
		5/15											
		6/15											
		7/15											
		8/15											
		9/15											
		10/15											
		11/15											
		12/15											
		13/15											
256 QAM	64800	2/15											
		3/15											
		4/15											
		5/15											
		6/15											
		7/15											
		8/15											
		9/15											
		10/15											
		11/15											
		12/15											

FFT Size: 16K			GI: 192 samples (D _x =32)	GI: 384 samples (D _x =16)	GI: 512 samples (D _x =12)	GI: 768 samples (D _x =8)	GI: 1024 samples (D _x =6)	GI: 1536 samples (D _x =4)	GI: 2048 samples (D _x =3)	GI: 2432 samples (D _x =3)	GI: 3072 samples (D _x =4)	GI: 3648 samples (D _x =4)	GI: 4096 samples (D _x =3)	
Mod	Code-length	Code rate	Calculated C/N	Calculated C/N	Calculated C/N	Calculated C/N	Calculated C/N	Calculated C/N	Calculated C/N	Calculated C/N	Calculated C/N	Calculated C/N	Calculated C/N	
		13/15												
256 QAM	16200	2/15												
		3/15												
		4/15												
		5/15												
		6/15												
		7/15												
		8/15												
		9/15												
		10/15												
		11/15												
		12/15												
		13/15												
		1024 QAM	64800	2/15										
3/15														
4/15														
5/15														
6/15														
7/15														
8/15														
9/15														
10/15														
11/15														
12/15														
13/15														
4096 QAM	64800			2/15										
		3/15												
		4/15												

FFT Size: 16K			GI: 192 samples (D _x =32)	GI: 384 samples (D _x =16)	GI: 512 samples (D _x =12)	GI: 768 samples (D _x =8)	GI: 1024 samples (D _x =6)	GI: 1536 samples (D _x =4)	GI: 2048 samples (D _x =3)	GI: 2432 samples (D _x =3)	GI: 3072 samples (D _x =4)	GI: 3648 samples (D _x =4)	GI: 4096 samples (D _x =3)
Mod	Code-length	Code rate	Calculated C/N	Calculated C/N	Calculated C/N	Calculated C/N	Calculated C/N	Calculated C/N	Calculated C/N	Calculated C/N	Calculated C/N	Calculated C/N	Calculated C/N
		5/15											
		6/15											
		7/15											
		8/15											
		9/15											
		10/15											
		11/15											
		12/15											
		13/15											

Table 5.7 Rayleigh Channel 32K FFT Configuration Mode Test Results

FFT Size: 32K			GI: 192 samples (D _x =32)	GI: 384 samples (D _x =32)	GI: 512 samples (D _x =24)	GI: 768 samples (D _x =16)	GI: 1024 samples (D _x =12)	GI: 1536 samples (D _x =8)	GI: 2048 samples (D _x =6)	GI: 2432 samples (D _x =6)	GI: 3072 samples (D _x =8,3)	GI: 3648 samples (D _x =8,3)	GI: 4096 samples (D _x =3)	GI: 4864 samples (D _x =3)
Mod	Code-length	Code rate	Calculated C/N	Calculated C/N	Calculated C/N	Calculated C/N	Calculated C/N	Calculated C/N	Calculated C/N	Calculated C/N	Calculated C/N	Calculated C/N	Calculated C/N	Calculated C/N
QPSK	64800	2/15												
		3/15												
		4/15												
		5/15												
		6/15												
		7/15												
		8/15												
		9/15												
		10/15												
		11/15												
		12/15												
		13/15												
		QPSK	16200	2/15										
3/15														
4/15														
5/15														
6/15														
7/15														
8/15														
9/15														
10/15														
11/15														
12/15														
13/15														
16 QAM	64800			2/15										
		3/15												
		4/15												
		5/15												

FFT Size: 32K			GI: 192 samples (D _x =32)	GI: 384 samples (D _x =32)	GI: 512 samples (D _x =24)	GI: 768 samples (D _x =16)	GI: 1024 samples (D _x =12)	GI: 1536 samples (D _x =8)	GI: 2048 samples (D _x =6)	GI: 2432 samples (D _x =6)	GI: 3072 samples (D _x =8,3)	GI: 3648 samples (D _x =8,3)	GI: 4096 samples (D _x =3)	GI: 4864 samples (D _x =3)
Mod	Code-length	Code rate	Calculated C/N	Calculated C/N	Calculated C/N	Calculated C/N	Calculated C/N	Calculated C/N	Calculated C/N	Calculated C/N	Calculated C/N	Calculated C/N	Calculated C/N	Calculated C/N
		6/15												
		7/15												
		8/15												
		9/15												
		10/15												
		11/15												
		12/15												
		13/15												
16 QAM	16200	2/15												
		3/15												
		4/15												
		5/15												
		6/15												
		7/15												
		8/15												
		9/15												
		10/15												
		11/15												
		12/15												
		13/15												
64 QAM	64800	2/15												
		3/15												
		4/15												
		5/15												
		6/15												
		7/15												
		8/15												
		9/15												

FFT Size: 32K			GI: 192 samples (D _x =32)	GI: 384 samples (D _x =32)	GI: 512 samples (D _x =24)	GI: 768 samples (D _x =16)	GI: 1024 samples (D _x =12)	GI: 1536 samples (D _x =8)	GI: 2048 samples (D _x =6)	GI: 2432 samples (D _x =6)	GI: 3072 samples (D _x =8,3)	GI: 3648 samples (D _x =8,3)	GI: 4096 samples (D _x =3)	GI: 4864 samples (D _x =3)
Mod	Code-length	Code rate	Calculated C/N	Calculated C/N	Calculated C/N	Calculated C/N	Calculated C/N	Calculated C/N	Calculated C/N	Calculated C/N	Calculated C/N	Calculated C/N	Calculated C/N	Calculated C/N
		10/15												
		11/15												
		12/15												
		13/15												
64 QAM	16200	2/15												
		3/15												
		4/15												
		5/15												
		6/15												
		7/15												
		8/15												
		9/15												
		10/15												
		11/15												
		12/15												
		13/15												
256 QAM	64800	2/15												
		3/15												
		4/15												
		5/15												
		6/15												
		7/15												
		8/15												
		9/15												
		10/15												
		11/15												
		12/15												
		13/15												

FFT Size: 32K			GI: 192 samples (D _x =32)	GI: 384 samples (D _x =32)	GI: 512 samples (D _x =24)	GI: 768 samples (D _x =16)	GI: 1024 samples (D _x =12)	GI: 1536 samples (D _x =8)	GI: 2048 samples (D _x =6)	GI: 2432 samples (D _x =6)	GI: 3072 samples (D _x =8,3)	GI: 3648 samples (D _x =8,3)	GI: 4096 samples (D _x =3)	GI: 4864 samples (D _x =3)
Mod	Code-length	Code rate	Calculated C/N	Calculated C/N	Calculated C/N	Calculated C/N	Calculated C/N	Calculated C/N	Calculated C/N	Calculated C/N	Calculated C/N	Calculated C/N	Calculated C/N	Calculated C/N
256 QAM	16200	2/15												
		3/15												
		4/15												
		5/15												
		6/15												
		7/15												
		8/15												
		9/15												
		10/15												
		11/15												
		12/15												
		13/15												
		1024 QAM	64800	2/15										
3/15														
4/15														
5/15														
6/15														
7/15														
8/15														
9/15														
10/15														
11/15														
12/15														
13/15														
4096 QAM	64800			2/15										
		3/15												
		4/15												
		5/15												

FFT Size: 32K			GI: 192 samples (D _x =32)	GI: 384 samples (D _x =32)	GI: 512 samples (D _x =24)	GI: 768 samples (D _x =16)	GI: 1024 samples (D _x =12)	GI: 1536 samples (D _x =8)	GI: 2048 samples (D _x =6)	GI: 2432 samples (D _x =6)	GI: 3072 samples (D _x =8,3)	GI: 3648 samples (D _x =8,3)	GI: 4096 samples (D _x =3)	GI: 4864 samples (D _x =3)
Mod	Code-length	Code rate	Calculated C/N	Calculated C/N	Calculated C/N	Calculated C/N	Calculated C/N	Calculated C/N	Calculated C/N	Calculated C/N	Calculated C/N	Calculated C/N	Calculated C/N	Calculated C/N
		6/15												
		7/15												
		8/15												
		9/15												
		10/15												
		11/15												
		12/15												
		13/15												

5.1.3 Impairment Paths

Impairment paths are lab-generated signals that are intended to simulate various challenging RF environment conditions. These signals are combined with other signals to investigate how the demodulator, or complete tuner, performs under scenarios that are more realistic than those generated in a controlled laboratory. Several useful impairment paths are the primary differentiator in the various tests that are described in the following subsections.

5.1.3.1 AWGN

5.1.3.1.1 AWGN Channel Description

AWGN testing will show minimum signal to noise (SNR) levels for specific modulation configuration settings in a Gaussian distributed noise environment. Only the noise generator will be supplied to the channel and all other impairments will not be applied.

Some combinations of receiver types and path impairments are less realistic and can be skipped if desired, but they are informative.

5.1.3.1.2 AWGN Channel Measurement Technique

Steps:

- 1) Set up test equipment as shown in Figure 5.1 with no Impairment Channel. (clean channel with no ghost or added noise).
- 2) Use ATSC 3.0 Modulator parameters of Configuration 1 in Annex B.1.
- 3) Set received input signal strength to -53dBm RF channel input, or appropriate IF signal amplitude for DUT. (Verify with Spectrum Analyzer.)
- 4) Tune DUT to signal and verify clean reception.
- 5) Set Noise Generator output power to -90 dBm.
- 6) Raise noise power until errors begin in the data stream.
- 7) Remove modulated signal and measure the noise power in the channel.
- 8) Log results in Table 5.8.
- 9) Remove noise and insert desired signal.
- 10) Raise noise power until L1-Detail errors appear.
- 11) Remove modulated signal and measure noise power in the channel.
- 12) Log results in Table 5.8.
- 13) Remove noise and insert desired signal.
- 14) Raise noise power until L1-Basic errors appear.
- 15) Remove modulated signal and measure noise power in the channel.
- 16) Log results in Table 5.8.
- 17) Remove noise and insert desired signal.
- 18) Raise noise power until Bootstrap recovery fails.
- 19) Remove modulated signal and measure noise power in the channel.
- 20) Log results in Table 5.8.

If a waterfall chart is desired, the measured error may be recorded for each 0.1 dB step of the noise generator.

5.1.3.1.3 AWGN Channel Results

Table 5.8 AWGN Channel Test Results

Parameter	Measured Channel Power	Calculated C/N
Desired Signal Level	-53 dBm or IF level:	
Noise power at stream error threshold		
Noise power at L1-Detail error threshold		
Noise power at L1-Basic error threshold		
Noise power at Bootstrap error threshold		

Note: BER and PER values are average results with one second periods.

5.1.3.2 TU-6 (Doppler @ 200km/hr at 695 MHz RF)

5.1.3.2.1 TU-6 Channel Description

Typical Urban 6 path channel testing will show minimum signal to noise (SNR) levels for specific modulation configuration settings in a typical urban mobile channel environment of 6 paths.

5.1.3.2.2 TU-6 Channel Measurement Technique

Steps:

- 1) Set up test equipment as shown in Figure 5.1 with Impairment Channel configured for TU-6 channel model as shown in Appendix A.5.
- 2) Use ATSC 3.0 Modulator parameters of Configuration 1 in Annex B.1.
- 3) Set received input signal strength to -53 dBm RF channel input, or appropriate IF signal amplitude for DUT. (Verify with Spectrum Analyzer.)
- 4) Tune DUT to signal and verify clean reception.
- 5) Set Noise Generator output power to -90 dBm.
- 6) Raise noise power until errors begin in the data stream.
- 7) Remove modulated signal and measure the noise power in the channel.
- 8) Log results in Table 5.9.
- 9) Re-insert desired signal.
- 10) Repeat steps 6 through 8 until L1-Detail errors appear and again until L1-Basic errors appear and again until Bootstrap recovery fails.
- 11) Also repeat test for ATSC 3.0 Modulator configurations in Annex B.1 with 8K and 16K FFT sizes. (129Hz Doppler criteria).

5.1.3.2.3 TU-6 Channel Results

Table 5.9 TU-6 Channel Test Results

Parameter	Measured Channel Power	Calculated C/N
Desired Signal Level	-53 dBm or IF level:	
Noise power at stream error threshold		
Noise power at L1-Detail error threshold		
Noise power at L1-Basic error threshold		
Noise power at Bootstrap error threshold		

Note: BER and PER values are average results with one second periods.

5.1.3.3 Single Path Rayleigh (Doppler @ 3km/hr at 177 MHz RF)

5.1.3.3.1 Single Path Rayleigh Description

Single Path Rayleigh path channel testing will show minimum signal to noise (SNR) levels for specific modulation configuration settings in a pure Rayleigh pedestrian channel environment.

5.1.3.3.2 Single Path Rayleigh Measurement Technique

Steps:

- 1) Set up test equipment as shown in Figure 5.1 with Impairment Channel configured for Single Path Rayleigh channel model as in Appendix A.4.1.
- 2) Use ATSC 3.0 Modulator parameters of Configuration 1 in Annex B.1.
- 3) Set received input signal strength to -53dBm RF channel input, or appropriate IF signal amplitude for DUT. (Verify with Spectrum Analyzer.)
- 4) Tune DUT to signal and verify clean reception.
- 5) Set Noise Generator output power to -90 dBm.
- 6) Raise noise power until errors begin in the data stream.
- 7) Remove modulated signal and measure the noise power in the channel.
- 8) Log results in Table 5.10.
- 9) Re-insert desired signal.
- 10) Repeat steps 6 through 8 until L1-Detail errors appear and again until L1-Basic errors appear and again until Bootstrap recovery fails.
- 11) Also repeat test for all six ATSC 3.0 Modulator configurations in Annex B.1.

5.1.3.3.3 Single Path Rayleigh Results

Table 5.10 Single Path Rayleigh Channel Test Results

Parameter	Measured Channel Power	Calculated C/N
Desired Signal Level	-53 dBm or IF level:	
Noise power at stream error threshold		
Noise power at L1-Detail error threshold		
Noise power at L1-Basic error threshold		
Noise power at Bootstrap error threshold		

Note: BER and PER values are average results with one second periods.

5.1.3.4 Pedestrian B (Doppler @ 3km/hr operating in the upper VHF (e.g., 177 MHz) and UHF (e.g., 695 MHz) Bands)

5.1.3.4.1 PedB Description

Pedestrian B channel testing will show minimum signal to noise (SNR) levels for specific modulation configuration settings with a person walking in a suburban environment holding a mobile receiver.

5.1.3.4.2 PedB Measurement Technique

Steps:

- 1) Set up test equipment as shown in Figure 5.1 with Impairment Channel configured for Pedestrian B channel model as in Appendix A.7.2.
- 2) Use ATSC 3.0 Modulator parameters of Configuration 1 in Annex B.1.

- 3) Set received input signal strength to -53 dBm RF channel input, or appropriate IF signal amplitude for DUT. (verify with Spectrum Analyzer).
- 4) Tune DUT to signal and verify clean reception.
- 5) Set Noise Generator output power to -90 dBm.
- 6) Raise noise power until errors begin in the data stream.
- 7) Remove modulated signal and measure the noise power in the channel.
- 8) Log results in Table 5.11.
- 9) Re-insert desired signal.
- 10) Repeat steps 6 through 8 until L1-Detail errors appear and again until L1-Basic errors appear and again until Bootstrap recovery fails.
- 11) Also repeat test for all six ATSC 3.0 Modulator configurations in Annex B.1.

5.1.3.4.3 PedB Results

Table 5.11 Pedestrian B Channel Test Results

Parameter	Measured Channel Power	Calculated C/N
Desired Signal Level	-53 dBm or IF level:	
Noise power at stream error threshold		
Noise power at L1-Detail error threshold		
Noise power at L1-Basic error threshold		
Noise power at Bootstrap error threshold		

Note: BER and PER values are average results with one second periods.

5.1.3.5 Single 0 dB echo (impulse function with one impulse delay ranging over 100 μ sec)

5.1.3.5.1 Single 0 dB Echo Description

Single 0 dB echo channel testing will show minimum signal to noise (SNR) levels for specific modulation configuration settings with a strong single multipath echo that varies in delay. This will stress the DUT channel equalization.

5.1.3.5.2 Single 0dB Echo Measurement Technique

Steps:

- 1) Set up test equipment as shown in Figure 5.1 with Impairment Channel configured for Single 0dB Echo channel model as in Appendix A.1.
- 2) Use ATSC 3.0 Modulator parameters of Configuration 1 in Annex B.1.
- 3) Set received input signal strength to -53 dBm RF channel input, or appropriate IF signal amplitude for DUT. (Verify with Spectrum Analyzer.)
- 4) Tune DUT to signal and verify clean reception.
- 5) Set Noise Generator output power to -90 dBm.
- 6) Raise noise power until errors begin in the data stream.
- 7) Remove modulated signal and measure the noise power in the channel.
- 8) Log results in Table 5.12.
- 9) Re-insert desired signal.
- 10) Repeat steps 6 through 8 until L1-Detail errors appear and again until L1-Basic errors appear and again until Bootstrap recovery fails.
- 11) Also repeat test for all six ATSC 3.0 Modulator configurations in Annex B.1.

5.1.3.5.3 Single 0 dB Echo Results

Table 5.12 Single 0 dB Echo Channel Test Results

Parameter	Measured Channel Power	Calculated C/N
Desired Signal Level	-53 dBm or IF level:	
Noise power at stream error threshold		
Noise power at L1-Detail error threshold		
Noise power at L1-Basic error threshold		
Noise power at Bootstrap error threshold		

Note: BER and PER values are average results with one second periods.

5.1.3.6 Long Multipath Tests: Time-Aligned and Symbol-Aligned Tests (Spot-check to detect difference between these two modes.)

5.1.3.6.1 Long Multipath Description

Long multipath channel testing will show minimum signal to noise (SNR) levels for specific modulation configuration settings with strong single multipath echo that varies in delay. This will stress the DUT channel equalization.

5.1.3.6.2 Long Multipath Measurement Technique

Steps:

- 1) Set up test equipment as shown in Figure 5.1 with Impairment Channel configured for 2 path ensemble channel model as in Appendix A.1 with long echo delays (range can be 1.95 μ sec up to 95% of the Guard Interval).
- 2) Use ATSC 3.0 Modulator parameters of Configuration 1 in Annex B.1.
- 3) Set received input signal strength to -53dBm RF channel input, or appropriate IF signal amplitude for DUT. (Verify with Spectrum Analyzer.)
- 4) Tune DUT to signal and verify clean reception.
- 5) Set Noise Generator output power to -90 dBm.
- 6) Raise noise power until errors begin in the data stream.
- 7) Remove modulated signal and measure the noise power in the channel.
- 8) Log results in Table 5.13.
- 9) Re-insert desired signal.
- 10) Repeat steps 6 through 8 until L1-Detail errors appear and again until L1-Basic errors appear and again until Bootstrap recovery fails.
- 11) Also repeat test for all six ATSC 3.0 Modulator configurations in Annex B.1.

5.1.3.6.3 Long Multipath Results

Table 5.13 Long Multipath Channel Test Results

Parameter	Measured Channel Power	Calculated C/N
Desired Signal Level	-53 dBm or IF level:	
Noise power at stream error threshold		
Noise power at L1-Detail error threshold		
Noise power at L1-Basic error threshold		
Noise power at Bootstrap error threshold		

Note: BER and PER values are average results with one second periods.

5.1.3.7 Single Dynamic Echo

5.1.3.7.1 Single Dynamic Echo Description

Single dynamic echo channel testing will show the capability to maintain synchronization with a channel that has alternating pre- and post-echoes from the main path in the presence of noise. This will stress the DUT channel tracking capability.

5.1.3.7.2 Single Dynamic Echo Measurement Technique

Steps:

- 1) Set up test equipment as shown in Figure 5.1 with Impairment Channel configured for Single Dynamic Echo channel model as in Appendix A.9.1 with no added white noise.
- 2) Vary delay of paths 2 and 3 between 0 and 2 μ sec.
- 3) Vary path 3 Doppler between 0 and 2 Hz.
- 4) Use ATSC 3.0 Modulator parameters of Configuration 1 in Annex B.1.
- 5) Set received input signal strength to -53 dBm RF channel input, or appropriate IF signal amplitude for DUT. (Verify with Spectrum Analyzer.)
- 6) Tune DUT to signal and verify clean reception.
- 7) Start with paths 2 and 3 at -7 dB power relative to path 1 and increase until errors begin in the data stream.
- 8) Log results of power difference between paths 2 (and 3) and path 1 in Table 5.14.
- 9) Increase paths 2 and 3 power until L1-Detail errors appear and again until L1-Basic errors appear and again until Bootstrap recovery fails.
- 10) Repeat test until full range of delay and Doppler in steps 2 and 3 are complete.
- 11) Also repeat test for all six ATSC 3.0 Modulator configurations in Annex B.1.

5.1.3.7.3 Single Dynamic Echo Results

Table 5.14 Single Dynamic Echo Channel Test Results

Doppler: (0 to 2 Hz)	Path 2 and 3 Delay (μ sec)		
	0 μ sec	...	2 μ sec
Power difference (dB) between path 1 and 2 at stream error threshold			
Power difference (dB) between path 1 and 2 at L1-Detail error threshold			
Power difference (dB) between path 1 and 2 at L1-Basic error threshold			
Power difference (dB) between path 1 and 2 at Bootstrap error threshold			

Table entries can be BER, PER values averaged with one second periods, ESR₅, Freq Lock, Timing Lock, AGC Levels or C/N estimates, etc., for each Doppler value.

5.1.3.8 Multiple Dynamic Echo

5.1.3.8.1 Multiple Dynamic Echo Description

Multiple dynamic echo channel testing will show the capability to maintain synchronization with a channel that has dynamic echoes in the presence of noise. This will stress the DUT channel tracking capability.

5.1.3.8.2 Multiple Dynamic Echo Measurement Technique

Steps:

- 1) Set up test equipment as shown in Figure 5.1 with Impairment Channel configured for Multiple Dynamic Echo channel model as in Appendix A.9.2.

- 2) Select a value for path 5 Doppler between 0 and 5 Hz.
- 3) Use ATSC 3.0 Modulator parameters of Configuration 1 in Annex B.1.
- 4) Set received input signal strength to -53 dBm RF channel input, or appropriate IF signal amplitude for DUT. (Verify with Spectrum Analyzer.)
- 5) Tune DUT to signal and verify clean reception.
- 6) Start with path 5 at -7 dB power relative to path 1 and increase until errors begin in the data stream.
- 7) Log results of path 5 power for each Doppler of path 5 in Table 5.15.
- 8) Increase path 5 power until L1-Detail errors appear and again until L1-Basic errors appear and again until Bootstrap recovery fails.
- 9) Repeat test until full range of power and Doppler in steps 2 and 6 are complete.
- 10) Also repeat test for all six ATSC 3.0 Modulator configurations in Annex B.1.

5.1.3.8.3 Multiple Dynamic Echo Results

Table 5.15 Multiple Dynamic Echo Channel Test Results

Parameter	Doppler (Hz)		
	0 Hz	...	5Hz
Path 5 power (dB) at stream error threshold	...		
Path 5 power (dB) at L1-Detail error threshold			
Path 5 power (dB) at L1-Basic error threshold			
Path 5 power (dB) at Bootstrap error threshold			

Table entries can be BER, PER values averaged with one second periods, ESR₅, Freq Lock, Timing Lock, AGC Levels or C/N estimates, etc. for each Doppler value.

5.1.4 Peak-to-Average Power Ratio

5.1.4.1 Peak-to-Average Power Ratio Description

The average power of a digitally modulated OFDM signal is of importance, since it determines the transmission range and most interference characteristics. For most of the system to be tested, the average power is constant (i.e., independent of scene content and motion). However, the peak power, in the form of transients, is data dependent and is greater than the maximum symbol power in a band-limited signal. The transient peak power is of concern in the design of transmitters and such high-power RF components as feed lines and transmitting antennas, due to the voltage stress imposed upon them. Efficient operation of high-power transmitters may require that some transients drive the transmitter toward saturation, resulting in compression of these peaks. Interference into adjacent channels may then result from third-order intermodulation due to AM/AM conversion (differential gain).

The frequency of occurrence of transient peaks above a specified level is statistical. The method described in this section should be used to determine the statistical transient peak-to-average power ratio for digital OFDM systems. This method provides the relative frequency of occurrence of transient peaks with respect to the average power. Note that the method cannot guarantee that a transient peak will never occur above the highest level measured. Also, note that in a practical situation in which some compression of peaks is occurring, the transient peak-to-average power ratio will be lower than the value resulting from laboratory testing using a highly linear RF test bed.

5.1.4.2 Peak-to-Average Power Ratio Measurement Technique

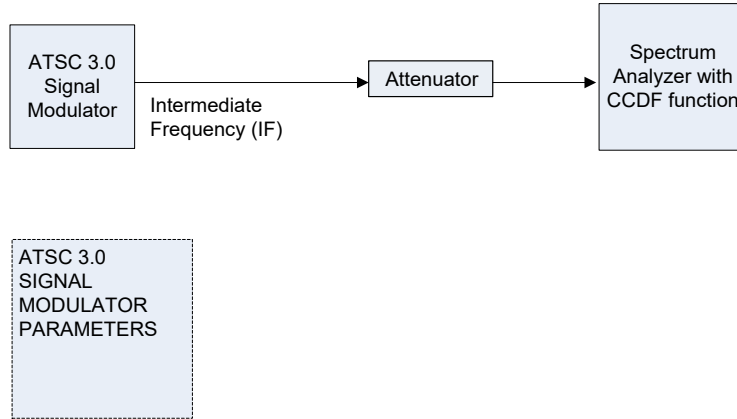

Figure 5.3 Peak-to-Average Power Ratio test setup

Steps:

- 1) Set up test equipment as shown in Figure 5.3.
- 2) Set the output of the ATSC 3.0 Modulator to use parameters of interest (e.g., Configuration 5 in Annex B.1 which has 32K FFT with 256 QAM, 64800 LDPC with 10/15 code rate)
- 3) Set input power level of Spectrum Analyzer to -30 dBm.
- 4) Set spectrum analyzer to sample at least 5 million samples with resolution bandwidth of 10 MHz.
- 5) Use Complementary Cumulative Distribution Function (CCDF) application within the spectrum analyzer to measure PAPR at a desired probability (e.g., 10^{-1} to 10^{-5}).
- 6) Repeat to verify stable measurements.
- 7) Tabulate results as a function of probability.

5.1.4.3 Peak-to-Average Power Ratio Results

Table 5.16 Peak-to-Average Power Ratio Results

Probability level (%)	dB above average

5.1.5 Single Frequency Network (SFN)

Lab setup for SFN testing may be found below in Figure 5.4.

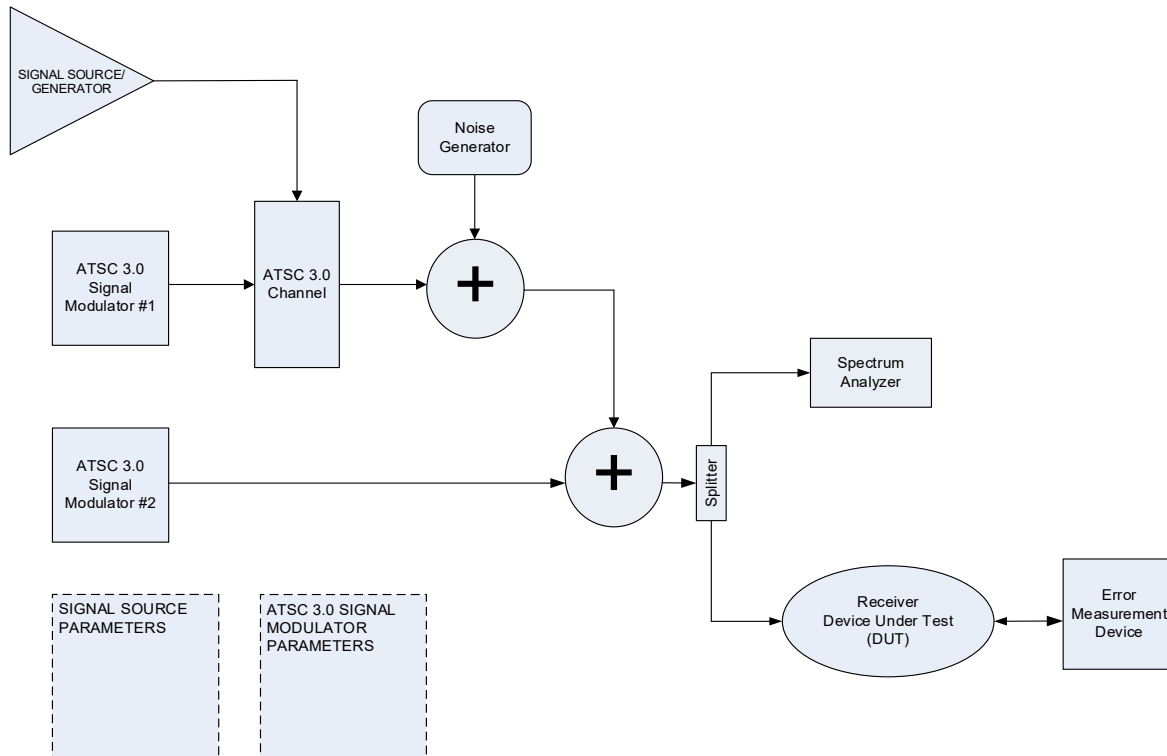

Figure 5.4 SFN test setup.

5.1.5.1 SFN 2-path Channel Description

The SFN 2-path channel test involves a desired signal and a copy of the desired signal that has been shifted in time by a number of microseconds from the desired signal. The desired signal should contain content exhibiting enough movement/action to clearly determine the point at which noticeable degradation in the video output of the device has occurred. The undesired signal, or time-shifted copy of the desired signal, in the SFN 2-path channel test is the echo. The echo is set to one of several power levels relative to the desired signal, thus creating a signal-to-echo ratio (S/E), as the time shift is extended in microseconds until TOV is detected. Due to the assumption that the strongest received signal is the most desired and a device would be oriented accordingly, there is no need to test a negative S/E ratio. The time shift is extended both by positive (lagging) and by negative (leading) microseconds from time zero, relative to the desired signal arrival time. The output of the SFN 2-path channel test is delay in microseconds versus S/E ratio curves.

5.1.5.2 SFN 2-path Channel Measurement Technique

Steps:

- 1) Set up test equipment as shown in Figure 5.4.
- 2) Use ATSC 3.0 Modulator parameters of Configuration 5 (MISO) in Annex B.1 for both modulators (TDCFS #1 applied to Modulator #1, TDCFS #2 applied to Modulator #2) and the Signal Source Generator configured with three paths.
 - a. Path 1: 0 dB power at 0 μ sec delay with 0 Hz Doppler
 - b. Path 2: 0 dB power at 0 μ sec delay with 0 Hz Doppler

- 3) Set desired received input signal strength to -28 dBm RF channel input, or appropriate IF signal amplitude for DUT. (Verify with Spectrum Analyzer.)
- 4) Set Noise Generator output power to -90 dBm.
- 5) Tune DUT to signal and verify clean reception.
- 6) Starting at a S/E ratio of 0 dB between the two paths, increase the delay (μsec) on path 2 until TOV.
- 7) Log results in Table 5.17.
- 8) Repeat steps 2 through 7 until L1-Detail errors appear and again until L1-Basic errors appear and again until Bootstrap recovery fails.
- 9) Increment the S/E ratio by 1 dB (set path 2 to -1 dB) and repeat steps 6 through 8 (continue repeating until incrementing the echo no longer affects the signal).
- 10) Repeat steps 2 through 10 for each of the other desired RF signal levels (-53 dBm, -68 dBm & TOV+3 dB). These are the results (μsec) for a leading echo.
- 11) Repeat steps 2 through 9 replacing path 1 with path 2. These are the results (μsec) for the lagging echo.
- 12) Also repeat test for all six ATSC 3.0 Modulator configurations in Annex B.1.

5.1.5.3 SFN 2-path Channel Results

Table 5.17 SFN 2-path Channel Results

Configuration	Desired Signal Level (dBm)	S/E (dB)	Frame Component	Echo Delay (μs)		
				Leading Echo (-)	Lagging Echo (+)	
1	-28	0	payload			
			L1-Detail			
			L1-Basic			
			bootstrap			
	1			payload		
				L1-Detail		
				L1-Basic		
				bootstrap		
	2			...		
...	-53	0	payload			
			...			
			...			
2	-28	0	payload			
			...			
...			

5.1.5.4 SFN 3-path Channel Description

SFN testing will show minimum signal to noise (SNR) levels for specific modulation configuration settings in a MISO channel of multiple transmitters and one receiver. This test exercises SFN synchronization of the DUT when two echo signals are present in the SFN environment and any channel pre-coding Time Diversity Code Filter Set (TDCFS) effects, as described in [5].

5.1.5.5 SFN 3-path Channel Measurement Technique

Steps:

- 1) Set up test equipment as shown in Figure 5.4.

- 2) Use ATSC 3.0 Modulator parameters of Configuration 5 (MISO) in Annex B.1 for both modulators (TDCFS #1 applied to Modulator #1, TDCFS #2 applied to Modulator #2) and the Signal Source Generator configured with three paths.
 - a. Path 1: 0 dB power at 0 μ sec delay with 0 Hz Doppler
 - b. Path 2: -21 dB power at -140.0 μ sec delay with 0 Hz Doppler
 - c. Path 3: -15 dB power at +140.0 μ sec delay with 0 Hz Doppler
- 3) Set received input signal strength to -53 dBm RF channel input, or appropriate IF signal amplitude for DUT. (Verify with Spectrum Analyzer.)
- 4) Set Noise Generator output power to -90 dBm.
- 5) Tune DUT to signal and verify clean reception.
- 6) Raise noise power until errors begin in the data stream.
- 7) Remove modulated signal and measure the noise power in the channel.
- 8) Log results in Table 5.18.
- 9) Re-insert ATSC 3.0 signal modulator outputs.
- 10) Repeat steps 6 through 8 until L1-Detail errors appear and again until L1-Basic errors appear and again until Bootstrap recovery fails.
- 11) Also repeat test for all six ATSC 3.0 Modulator configurations in Annex B.1.

5.1.5.6 SFN 3-path Channel Results

Table 5.18 SFN Channel Test Results

Parameter	Measured Channel Power	Calculated C/N
Desired Signal Level	-53 dBm or IF level:	
Noise power at stream error threshold		
Noise power at L1-Detail error threshold		
Noise power at L1-Basic error threshold		
Noise power at Bootstrap error threshold		

Note: BER and PER values are average results with one second periods.

5.2 Lab Performance – System

Lab setup for channel impairment testing may be found below in Figure 5.5. This is very similar to Figure 5.1, but with the RF Up-Converter added, as shown in Figure 4.1, that allows for a complete receiver system (i.e., including a tuner) to be tested.

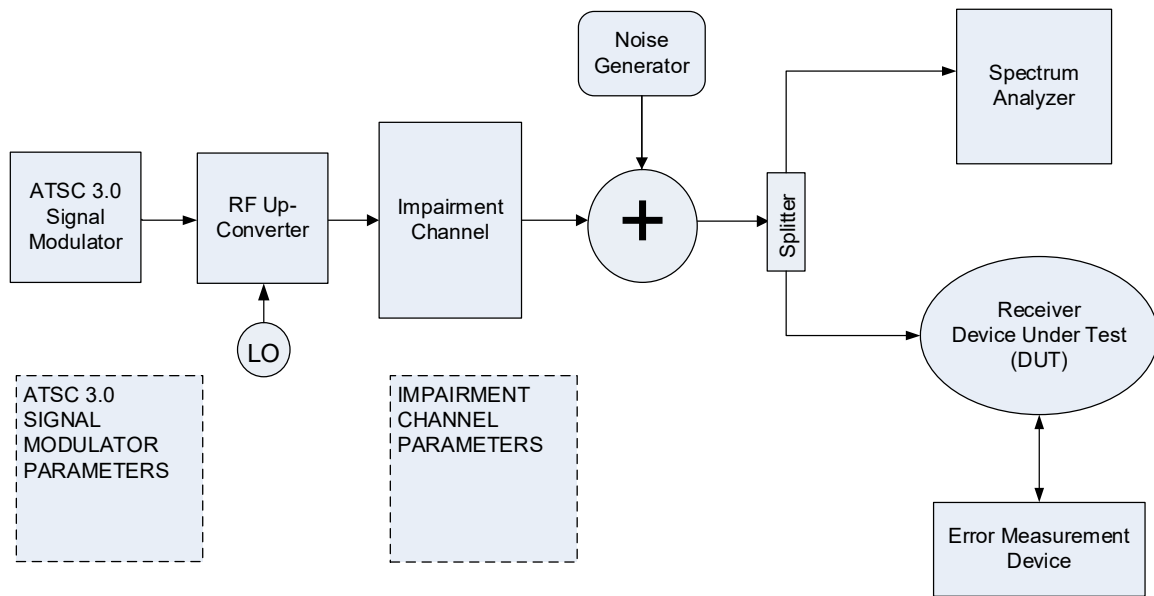

Figure 5.5 Lab Performance system setup.

Tests with a tuner should include weak, moderate, strong, and 3dB over weakest signal TOV (TOV+3 dB) signal levels to account for non-linearities of the tuner. Weak signal levels of -68 dBm, moderate signal levels of -53 dBm and strong signal levels of -28 dBm were typically used in ACATS testing for the desired signals and can be used here again.

5.2.1 AGC Dynamic Range

5.2.1.1 AGC Dynamic Range Description

Receiver sensitivity will vary depending on architecture, device type, tuner noise figure, self-inflicted tuner front-end electromagnetic interference (EMI), and many other factors. For broadcasting, the receiver range of operation can start from the system noise floor up to full power reception close to a transmitter. First, the receiver noise input power (P_N) needs to be found.

Receiver noise input power is determined from the thermal noise power equation plus a tuner noise figure (F). Thermal noise power is:

$$N_o = k * T * B \text{ [Watts]}$$

where,

$$k = \text{Boltzmann's constant} = 1.3807 * 10^{-23} \left[\frac{\text{Joules}}{\text{Kelvin}} \right]$$

$$T = \text{Ambient temperature [Kelvin]}$$

$$B = \text{Bandwidth [Hertz]}$$

Antenna temperature will vary depending on location (outside or inside) and time of the year. On average, the ambient temperature can be 290 Kelvin (62.33° Fahrenheit).

Bandwidth is the signal bandwidth within 6, 7, or 8 MHz channels, and for example calculations the signal bandwidth of Configuration 6 in Appendix B.1 is 5.83 MHz.

Thus the noise floor of an antenna is

$$N_o = 1.3807 * 10^{-23} * 290 * 5832000 [Watts]$$

$$N_o = 2.335150 * 10^{-14} [Watts]$$

Putting into decibels,

$$N_o = 10 * \text{Log}_{10}(2.335150 * 10^{-14}) = -136.3169 [dBW]$$

$$N_o = -106.3169 [dBm]$$

This is the thermal noise floor, adding in tuner noise figure of 6dB (typically used in other systems) gives receiver noise input power (P_N).

$$P_N = F_{tuner} + 10 * \log_{10}(k * T * B)$$

$$P_N = 6 - 106.3169 [dBm] = -100.3169 [dBm]$$

System noise needs to add other factors like tuner noise figure (F_{tuner}) and implementation loss $L_{implementation}$ regarding digital implementation of A/D, demodulation algorithms, bit widths carried in demodulators, etc.

$$N_{system} = N_o + F_{tuner} + L_{implementation}$$

ATSC 3.0 can operate data payloads at -6 dB SNR, which are signal powers below system noise levels, but for AGC dynamic range only the system noise level will be seen. RF input levels are expected to range from at least the ‘Strong’ signal level (typically defined as -28 dBm) down to the noise floor of the system near -100 dBm, which is just over 70 dB of dynamic range. Tuner noise figures and implementation loss impact the operating points starting at -6 dB SNR, but the test can begin at -100 dBm. Stronger RF signal levels above -28 dBm (e.g., -8 dBm, as recommended by ATSC) can be expected if receivers are close to transmitters (or repeaters).

Gain control of this RF signal level needs to be quick enough to avoid errors in output data during fast dynamic signal conditions and therefore automatic gain control is anticipated. There are likely to be two stages of gain control due to need of greater than 70 dB dynamic range; one may be in the tuner and one may be in the demodulator. Feedback loop design should compensate for correct overlap of these two feedback loops to avoid gaps in the system gain curve (of V_{out} / V_{in}).

5.2.1.2 AGC Dynamic Range Measurement Technique

Steps:

- 1) Set up test equipment as shown in Figure 5.5 with no Impairment Channel. (clean channel with no ghost or added noise).
- 2) Use ATSC 3.0 Modulator parameters of Configuration 6 in Annex B.1.
- 3) Set received input signal strength to -66 dBm on RF channel 30 (569 MHz center), (verify with Spectrum Analyzer) and add a 40 dB attenuation pad between the splitter and DUT.

- 4) Tune DUT to signal and verify clean reception.
- 5) Log AGC voltage level results in Table 5.19.
- 6) Increase received input signal strength by 1dB.
- 7) Repeat steps 4 through 6 to find full dynamic range (removing 40dB attenuation pad when appropriate).

5.2.1.3 AGC Dynamic Range Results

Table 5.19 AGC Dynamic Range Test Results

Desired Signal Level	Measured AGC Level
-106 dBm	
-105 dBm	
-104 dBm	
...	

Note: measured AGC value can be percentage, or voltage value or any register reading depending on device type.

5.2.2 Frequency Range

5.2.2.1 Frequency Range Description

ATSC 3.0 receivers should be able to tune to all available low VHF, high VHF and UHF channels currently allocated by the FCC. This frequency range is shown in Table 5.20.

Table 5.20 Channel Band Frequencies for the United States

Frequency Band	Frequencies	Channel Center Frequencies
Low Very High Frequency (VHF)	54.0 → 72.0 MHz and 76.0 → 88.0 MHz	{57.0, 63.0, 69.0, 79.0, 85.0} MHz
High Very High Frequency (VHF)	174.0 → 216.0 MHz	{177.0, 183.0...213.0} MHz
Ultra High Frequency (UHF)	470.0 → 698.0 MHz	{473.0, 479.0...695.0} MHz

5.2.2.2 Frequency Range Measurement Technique

Steps:

- 1) Set up test equipment as shown in Figure 5.5 with no Impairment Channel (clean channel with no ghost or added noise).
- 2) Use ATSC 3.0 Modulator parameters of Configuration 6 in Annex B.1.
- 3) Set the RF Up-converter to channel center frequencies indicated in Table 5.20.
- 4) Set received input signal strength to -53dBm RF channel input. (Verify with Spectrum Analyzer.)
- 5) Tune DUT to signal and verify clean reception.
- 6) Log reception capability (yes/no) results in Table 5.21.
- 7) Repeat steps 3 through 6 for all channel center frequencies in the three broadcast bands.

5.2.2.3 Frequency Range Results

Table 5.21 Frequency Range Test Results

6MHz Channel Center Frequencies	Reception (yes/no)
Low VHF Band	
High VHF Band	
UHF Band	

Note: there is variation on this for 7 and 8MHz channel countries and their respective country band plans.

5.2.3 Phase Noise

5.2.3.1 Phase Noise Description

Phase noise relates to short-term frequency deviations of a signal during an observed time window (short). The short term stability (or lack of) will spill energy away from intended standing carrier wave. A common description of phase noise is with single-sideband phase noise which is denoted here as $\mathcal{L}(f)$. Single sideband phase noise is the ratio of power spectral density measured at a certain frequency offset from a carrier tone input to the total power of the carrier signal. As detailed in [8], the phase instability of a signal is characterized in the frequency domain by the power spectral density of instantaneous phase fluctuations $S_\phi(f)$ given by

$$S_\phi(f) = \frac{(\Delta \phi_{rms}(f))^2}{BW}$$

where the numerator term is the mean-square phase fluctuation at an offset frequency f ($0 < f < \infty$) from the carrier frequency f_0 . The denominator term is the equivalent noise bandwidth of the measurement system. This $S_\phi(f)$ is a single-sided double-sideband unit of measure. For the single-sideband measurement form ($\mathcal{L}(f)$),

$$\mathcal{L}(f) = \frac{S_\phi(f)}{2}$$

When $\mathcal{L}(f)$ is expressed in decibels, $10 \cdot \log_{10}(\mathcal{L}(f))$ has units dBc/Hz, that is dB below the carrier in a 1Hz bandwidth. When the integrated phase noise power for offset frequencies $0 < f < \infty$ is less than 0.01 rad^2 , $\mathcal{L}(f)$ can be viewed as the ratio of phase-noise power in a single sideband to the carrier power.

$$\mathcal{L}(f) = \frac{1}{2} S_\phi(f) = \frac{P_{SSB}(f)}{P_C} \Big|_{BW=1Hz}$$

Which is to say

$$\mathcal{L}(f) = \frac{\text{Area of 1Hz bandwidth at offset frequency } f}{\text{Total area under the curve}}$$

The criteria of integrated phase noise power being less than 0.01 rad^2 (0.1 radian phase noise) puts an upper bound on a region of validity for phase noise measurements. The small angle criterion is a line with slope -10 dB/decade passing through a 1 Hz offset at -30 dBc/Hz . This represents a peak phase deviation of approximately 0.1 radians integrated over any one decade of

offset frequency. Any measurement below this upper bound line can have a high degree of confidence. This puts measurements to be below -70 dBc/Hz @ 10 kHz frequency offset for this test methodology.

OFDM systems are sensitive to phase noise because information from a modulation / coding symbol cell translates between carriers in the frequency domain. Phase noise will alter the received amplitude value of carriers throughout the number of active carriers within the FFT. Low phase noise helps accurately capture the amplitudes of each carrier, especially in large FFT sizes and higher order modulations (e.g., 1024 and 4096 QAM). Phase noise will largely come from a tuner, or local oscillator driving demodulation, etc. and the amount of phase noise increases with each frequency conversion that occurs in a receiver. Therefore, it is necessary to determine the effect of phase noise on receiver performance and quantify the amount of randomly injected phase noise modulations required to cause perceptible degradation.

5.2.3.2 Phase Noise Measurement Technique

Steps:

- 1) Set up test equipment as shown in Figure 5.5 with no Impairment Channel (clean channel with no ghost or added noise).
- 2) Set RF up-converter to 569.0 MHz (Channel 30).
- 3) Phase modulate the upconverter local oscillator (LO). There are many profiles of phase noise, but receivers are expected to tolerate phase noise that decays at a rate of 20 dB per decade of frequency offset over a range of at least 500 Hz to 100 kHz, with a value of -80 dBc/Hz at 20 kHz offset, equivalent to the phase noise profile as described in [10]. (Some test equipment have different filter profiles for phase noise generation.)
- 4) Set received input signal strength (of peak) to -53 dBm RF channel input. (Verify with Spectrum Analyzer.)
- 5) Tune DUT to signal.
- 6) Determine the phase noise setting at which errors begin in the data stream, a Threshold of Visibility (TOV), with a resolution of 0.1dB. One method of accomplishing this would be to use a large step size in the phase noise to identify the waterfall region and then switch to smaller step sizes to identify the exact TOV point.
- 7) Log phase noise result in Table 5.22.
- 8) Other RF up-converter values may be used if desired—low VHF (e.g., Channel 3) and high VHF (e.g., Channel 10).

5.2.3.3 Phase Noise Results

Table 5.22 Phase Noise Results

6MHz Channel Center Frequencies	Phase noise (dBc/Hz)
UHF band 569.0 MHz tone	
High VHF band 195.0 MHz tone	
Low VHF band 63.0 MHz tone	

5.2.4 Impulse Noise

Lab setup for impulse noise testing may be found in Figure 5.6.

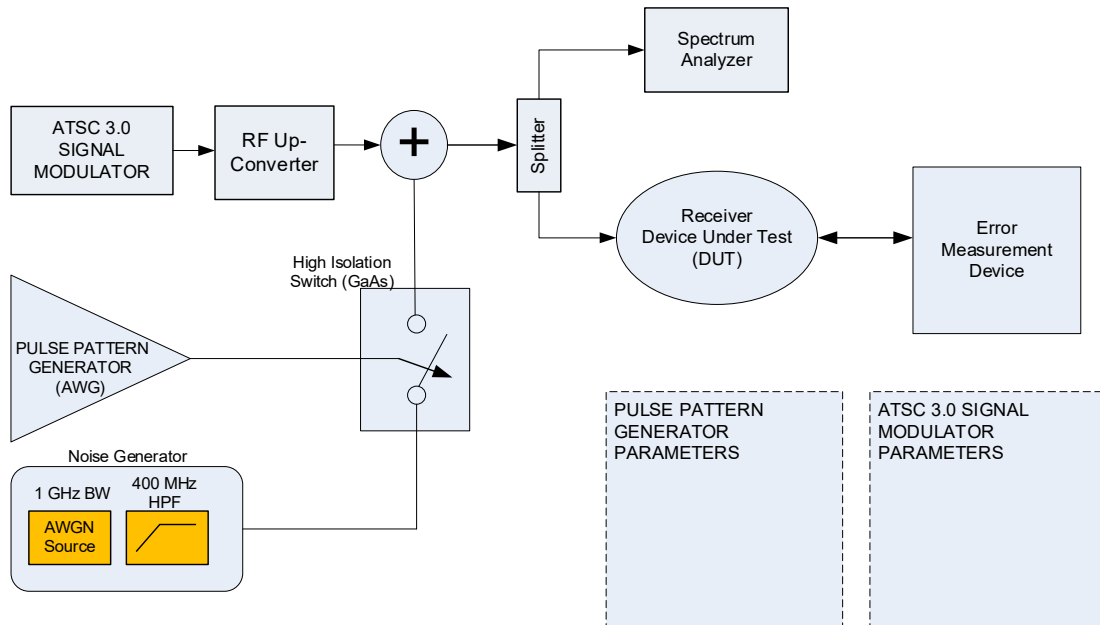

Figure 5.6 Impulse noise test setup.

Burst length and power depends on time interleaver length and FEC. Note that many noise simulation methods exist.

5.2.4.1 Impulse Noise Description

Impulse Noise testing will show tolerance levels to in-band spurious noise for specific modulation configuration settings. This type of noise can come from dishwashers, some LED light bulbs, fluorescent and incandescent light switches being turned on, ignition noise in vehicles, etc.

There are a variety of impulse noise patterns in the environment. One modeling example of that environment was written in paper [7]. A description of impulse noise can be seen in Figure 5.8.

Impulse noise pulse patterns may be programmed into popular broadcast test equipment³, but arbitrary waveform generators with I/Q vectors and RF up-converters may also be used if the waveforms can be verified to match expected pulse patterns. Arbitrary waveform generator pulses of AWGN noise would need to be bandwidth limited to given pulse widths. Also the reference interferer power would need to be determined for the waveform in order to calibrate Desired / Undesired ratios. This reference power would have to be based on the RMS of the active portion of the pulses, but as each pulse is different averaging is needed. Note, it is beneficial to use popular test equipment which automatically adjusts power levels with these considerations. If possible, both methods can be tested on a receiver to verify repeatable results. An example set of pulse patterns for impulse noise are given in Table 5.23.

³ For example, Rohde & Schwarz SFU or Broadcast Test Center (BTC).

Table 5.23 Impulse Noise Pulse Patterns

Noise Type	Model	Pulse Spacing (μsec)	Burst Duration (pulses per burst)	Burst Duration (μsec)	Effective Burst Duration τ_E
N1	Central Heating 2	25 ±10	6	75.25→175.25	1500 nsec
N2	Central Heating 3	2 ±0.5	2	1.75→2.75	500 nsec
N3	Gas Range Ignition	1.5 ±0.5	20	19.25→38.25	5000 nsec
N4	Dishwasher	12.5 ±2.5	10	90.25→135.25	2500 nsec
N5	Fluorescent lights	25 ±20	2	5.25→45.25	500 nsec
N6	Traffic 3A	7.5 ±2.5	2	5.25→10.25	500 nsec
N7	Traffic 3B	N/A	1	N/A	250 nsec

Pulse spacing is given as a mid-range value with a certain ± dither factor.

A description of these parameters is given in Figure 5.7 and Figure 5.8 where a classic gated AWGN signal is used to approximate impulse noise.

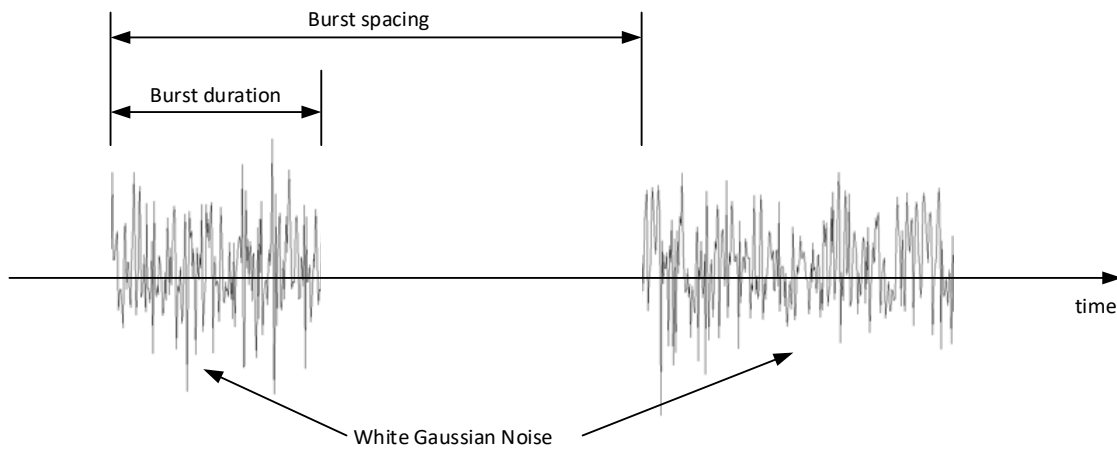

Figure 5.7 Classic gated AWGN test waveform.

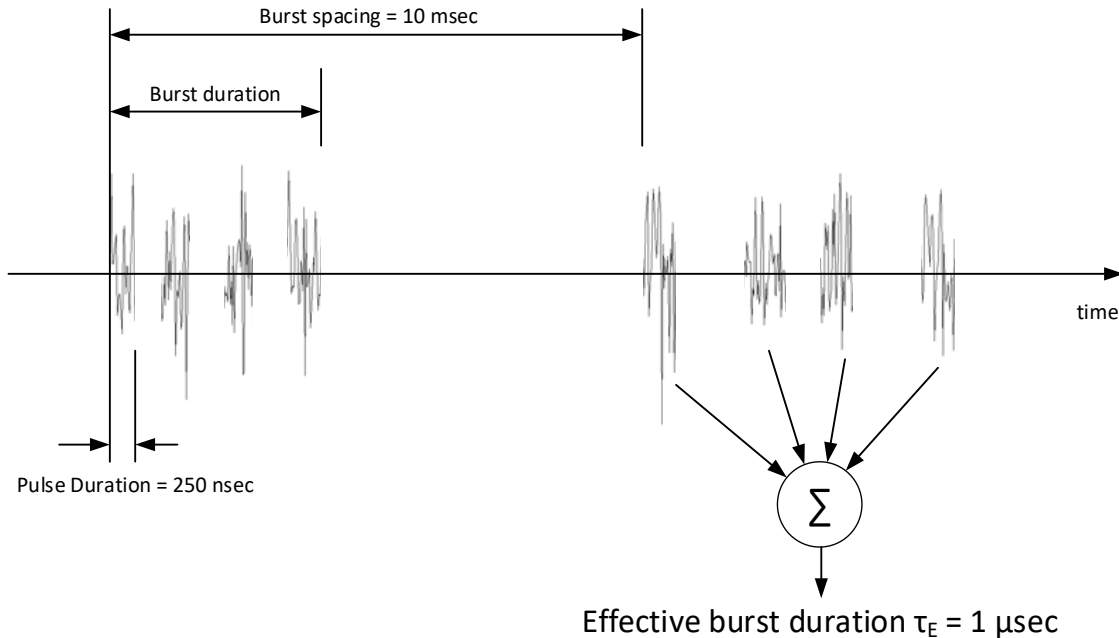

Figure 5.8 Gated squared AWGN test waveform.

5.2.4.2 Impulse Noise Measurement Technique

Steps:

- 1) Set up test equipment as shown in Figure 5.6.
- 2) Use ATSC 3.0 Modulator parameters of Configuration 1 in Annex B.1.
- 3) Set received input signal strength to -53 dBm on RF channel 30 (569 MHz center). (Verify with Spectrum Analyzer.)
- 4) With the high isolation switch closed, set noise pulse amplitude A to level A_{ref} starting point (-90 dBm) and measure corresponding interference level $I = I_{ref}$ within the 6 MHz signal bandwidth with the spectrum analyzer.
- 5) Set pulse duration to constant and fixed 250 nsec.
- 6) Set pulse spacing so it follows a uniform distribution.
- 7) Use Pulse Generator waveform N1 listed in Table 5.23 to gate the noise source.
- 8) Tune DUT to signal and verify clean reception.
- 9) Raise noise pulse amplitude A until errors begin in the data stream.
- 10) Remove modulated signal and measure the noise power in the channel.
- 11) Log results in Table 5.24.
- 12) Re-insert desired signal.
- 13) Increase noise pulse amplitude A until L1-Detail errors appear and again until L1-Basic errors appear and again until Bootstrap recovery fails.
- 14) Repeat test for all Pulse Generator waveforms in Table 5.23 and possibly in RF channel 6 (85 MHz center).

5.2.4.3 Impulse Noise Results

For each noise amplitude level, calculate the theoretical windowed C/I as follows:

$$\left(\frac{C}{I}\right)_W = C - I_{ref} + A - A_{ref} + 10 \log_{10} \left(\frac{T_u}{\tau_E}\right)$$

where T_u is the OFDM symbol duration time. Time interleaver gain may also be added.

Time interleavers spread the noise across symbols and therefore this spreading can be factored into performance. Time interleaver gain, or the amount of time over which symbols are spread can be calculated as:

$$T_{intGain} = 10 * \log_{10} \left(\frac{T_{int}}{T_u}\right)$$

Where T_u is the symbol duration time calculated with:

$$T_u = FFTsize * T$$

Where T is the elementary period = $1/F_s$; e.g., for a sample frequency of 6.912 MHz, the elementary period $T = 0.145 \mu\text{sec}$.

Interleaving time T_{int} can be calculated as

$$T_{int} = T_u * \left[\frac{\left(\frac{FEC \text{ block length}}{\text{bits per cell}}\right) * int \left(\frac{FEC \text{ blocks per int'l frame}}{TI \text{ block per int'l frame}}\right)}{\# \text{ cells per symbol}} \right]$$

The number of cells per symbol comes from Table 7.2, 7.3 and 7.4, 7.5 of [4] and FEC block lengths, TI block lengths are all chosen given the memory constraint of 2^{19} cells. As a result,

$$T_{intGain} = 10 * \log_{10} \left[\frac{\left(\frac{FEC \text{ block length}}{\text{bits per cell}}\right) * int \left(\frac{FEC \text{ blocks per int'l frame}}{TI \text{ block per int'l frame}}\right)}{\# \text{ cells per symbol}} \right]$$

Table 5.24 Impulse Noise Test Results

Parameter	Measured Channel Power	Calculated C/N Threshold
Desired Signal Level	-53dBm or IF level:	
Noise power at stream error threshold		
Noise power at L1-Detail error threshold		
Noise power at L1-Basic error threshold		
Noise power at Bootstrap error threshold		

Note: BER and PER values are average results with one second periods.

Plot C/N vs. windowed (C/I) at the points of DUT failure.

5.2.5 AWGN with Power Levels: Weak, Moderate, Strong

5.2.5.1 AWGN Channel Description

AWGN testing will show minimum signal to noise (SNR) threshold levels for specific modulation configuration settings in a Gaussian distributed noise environment. Only the noise generator will be supplied to the channel and all other impairments will not be applied.

5.2.5.2 AWGN Channel Measurement Technique

Steps:

- 1) Set up test equipment as shown in Figure 5.5 with no Impairment Channel. (clean channel with no ghost or added noise).
- 2) Use ATSC 3.0 Modulator parameters of Configuration 1 in Annex B.1.
- 3) Set received input signal strength to -28 dBm on RF channel 30 (569 MHz center). (Verify with Spectrum Analyzer.)
- 4) Tune DUT to signal and verify clean reception.
- 5) Set Noise Generator output power to -90 dBm.
- 6) Raise noise power until errors begin in the data stream.
- 7) Remove modulated signal and measure the noise power in the channel.
- 8) Log results in Table 5.25.
- 9) Remove noise and insert desired signal.
- 10) Repeat steps 6 through 8 to find preamble and bootstrap error thresholds.
- 11) Also repeat test for -53 dBm and -68 dBm desired power levels.

5.2.5.3 AWGN Channel Results

Table 5.25 AWGN Channel Test Results

Parameter	Measured Channel Power	Calculated C/N
Desired Signal Level	{ $-28, -53, -68$ } dBm	
Noise power at stream error threshold		
Noise power at L1-Detail error threshold		
Noise power at L1-Basic error threshold		
Noise power at Bootstrap error threshold		

Note: BER and PER values are average results with one second periods.

5.2.6 Interference with ACI, CCI, etc.

Lab setup for Adjacent Channel Interference (ACI) / Co-Channel Interference (CCI) testing can be found below in Figure 5.9.

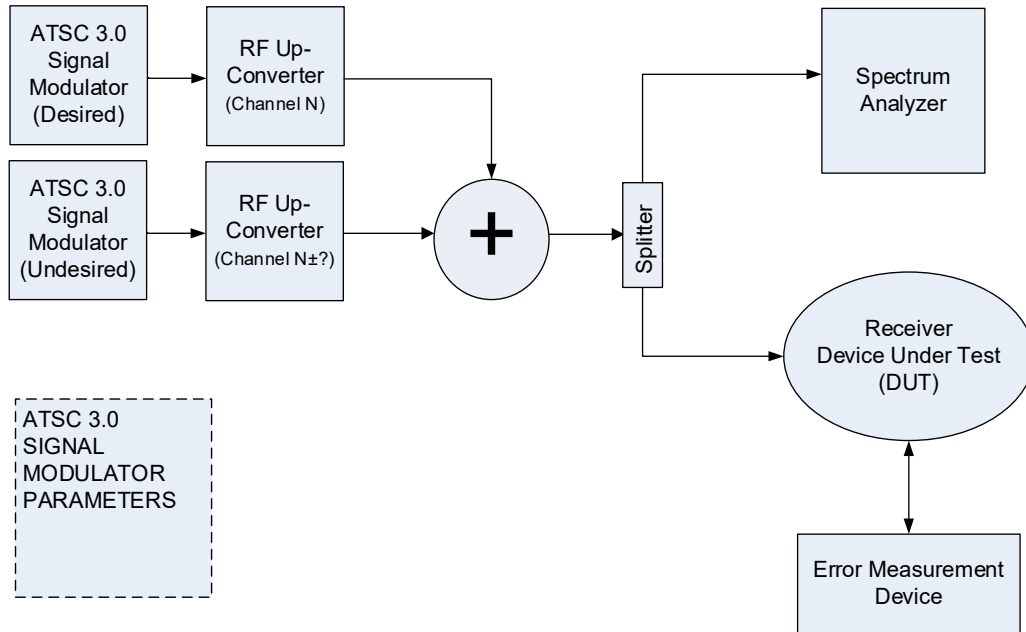

Figure 5.9 ACI/CCI test setup.

Note: Multiple channel impairments ($N \pm 1$, $N \pm 2$, $N \pm 3$, $N + K$, $N + 2K$, etc.) may be of interest.

5.2.6.1 Digital Adjacent Channel Interference Description

Adjacent Channel(s) Interference tests for demodulator DUTs applies for individual $N + 1$ and $N - 1$ signal interferers, and further adjacent channel ($N \pm 2$, $N \pm 3$, $N \pm 4$) interferers. This test looks at undesired digital $N \pm 1$ channel energy interfering with desired channel N energy; i.e., how well the receiver filtering (particularly in the tuner) can reject unwanted adjacent channel energy.

5.2.6.2 Digital ACI Measurement Technique

Steps:

- 1) Set up test equipment as shown in Figure 5.9.
- 2) Use ATSC 3.0 Modulator parameters of Configuration 1 in Annex B.1 for Desired modulator in channel 'N'.
- 3) Set desired channel 'N' to 569.0 MHz (Channel 30).
- 4) Set desired channel 'N' received input signal strength to -53 dBm RF channel input. (Verify with Spectrum Analyzer.)
- 5) Use ATSC 3.0 Modulator parameters of Configuration 1 in Annex B.1 for Undesired modulator in channel ' $N \pm 1$ '.
- 6) Set undesired channel ' $N \pm 1$ ' to 575.0 MHz (i.e., plus one 6 MHz signal bandwidth).
- 7) Set undesired channel ' $N \pm 1$ ' received input signal strength to -33 dBm RF channel input (verify with Spectrum Analyzer).
- 8) Tune DUT to channel 'N' and verify clean reception.
- 9) Reduce desired channel power until errors begin in the data stream.
- 10) Remove undesired modulated signal and measure the desired modulated signal power.
- 11) Log measured results in Table 5.26.

- 12) Re-insert undesired modulated signal.
- 13) Repeat steps 9 through 11 until L1-Detail errors appear and again until L1-Basic errors appear and again until Bootstrap recovery fails.
- 14) Repeat test for other adjacent channels (N-1 or N+1, or further offset channels).

5.2.6.3 Digital ACI Results

Table 5.26 Digital ACI Test Results

Parameter	Measured Channel Power	Calculated D/U
Undesired Signal Level	-33 dBm	-20dB
Desired power at stream error threshold		
Desired power at L1-Detail error threshold		
Desired power at L1-Basic error threshold		
Desired power at Bootstrap error threshold		

Note: BER and PER values are average results with one second periods.

5.2.6.4 Long Term Evolution (LTE) Adjacent Channel Interference Description

Adjacent Channel Interference tests for demodulator DUTs applies for $N + 1$ and $N - 1$, and further adjacent channel ($N \pm 2$, $N \pm 3$, $N \pm 4$) interferences test tuner filters. This test looks at undesired LTE cellphone (upstream) or base station (downstream) $N \pm 1$ channel energy interfering with desired digital channel N energy; i.e., how well the receiver filtering can reject unwanted adjacent channel energy. Three different traffic loads in LTE are used for this test as power levels of LTE signals vary upon traffic loads. The relevant interferer power in these tests is the licensed power rather than the long term RMS power of the signal (which is measured over a period long enough to average out the power fluctuations of the bursts in the LTE signal). The licensed power is the RMS power measured over the highest power burst of the signal. It can be measured with a spectrum analyzer in zero span mode with gated power cursors, or it can be calculated by measuring the long term RMS power of the signal and adding in the relevant licensed to average power ratio (LAPR) which is approximately 8.3 dB for the LTE_BS-idle_V2 signal, 0 dB for the LTE_BS-100pc_V2 signal and 9.7 dB for the LTE_UE_1Mbs_V2 signal. All these signals are based on a 10 MHz LTE channel bandwidth. These vectors of LTE signals are available from NorDig in IQ sample files at https://www.dropbox.com/s/edstt2arhj2v8q6/NorDig_LTE_interference_IQ_files.zip?dl=0.

5.2.6.5 LTE ACI Measurement Technique

Steps: Use test procedure summary of [2].

5.2.6.6 LTE ACI Results

Table 5.27 LTE ACI Test Results

Parameter	Measured Channel Power	Calculated D/U
Undesired Signal Level	-15 dBm	
Desired power at stream error threshold		
Desired power at L1-Detail error threshold		
Desired power at L1-Basic error threshold		
Desired power at Bootstrap error threshold		

Note: BER and PER values are average results with one second periods.

See [9] for acceptable levels of interference according to the FCC OET-74.

5.2.6.7 Digital Co-Channel Interference Description

Co-Channel Interference tests demodulator DUTs for the amount of undesired energy within the signal bandwidth of desired energy. This relates to coverage areas of same frequency transmitters and how far apart they need to be spaced. Results of this test significantly depend on the desired signal configuration parameters.

Note, this test uses ATSC 3.0 signal for undesired energy, but using ATSC 1.0 is also a ‘nice to have’ data point.

5.2.6.8 Digital CCI Measurement Technique

Steps:

- 1) Set up test equipment as shown in Figure 5.9.
- 2) Use ATSC 3.0 Modulator parameters of Configuration 1 in Annex B.1 for Desired modulator in channel ‘N’.
- 3) Set desired channel ‘N’ to 569.0 MHz (Channel 30).
- 4) Set desired channel ‘N’ received input signal strength to –53 dBm RF channel input. (Verify with Spectrum Analyzer.)
- 5) Use ATSC 3.0 Modulator parameters of Configuration 1 in Annex B.1 for Undesired modulator in the same channel ‘N’.
- 6) Set undesired signal to the same channel ‘N’ of 569.0 MHz (Channel 30).
- 7) Set undesired signal strength to –50 dBm RF channel input (verify with Spectrum Analyzer) and insert a 40 dB attenuation pad between the splitter and DUT.
- 8) Tune DUT to channel ‘N’ and verify clean reception.
- 9) Increase undesired signal strength until errors begin in the data stream.
- 10) Remove desired modulated signal and measure the undesired modulated signal power.
- 11) Log measured results in Table 5.28.
- 12) Re-insert the desired modulated signal.
- 13) Repeat steps 9 through 11 until L1Detail errors appear and again until L1Basic errors appear and again until Bootstrap recovery fails.

Note: This test may have varying results from trial to trial. Multiple trials may be needed and report the worst performing trial.

5.2.6.9 Digital CCI Results

Table 5.28 Digital CCI Test Results

Parameter	Measured Channel Power	Calculated D/U
Desired Signal Level	-53dBm	
Undesired power at stream error threshold		
Undesired power at L1-Detail error threshold		
Undesired power at L1-Basic error threshold		
Undesired power at Bootstrap error threshold		

Note: BER and PER values are average results with one second periods.

Annex A: RF Channel Profile Descriptions

A.1 TWO PATH ENSEMBLE

Single 0dB echo profile has one impulse function with one impulse delay ranging from 1 sample delay (flat fade) to 100 μ sec.

Table A.1.1 Two Path Ensemble

Path	Path 1	Path 2	Path 3	Path 4	Path 5	Path 6
Profile	Const Φ	Const Φ	N/A Φ	N/A	N/A	N/A
Path Loss (dB)	0.0	0.0	-	-	-	-
Delay (μ sec)	0.0	variable	-	-	-	-
Phase ($^{\circ}$ deg)	0.0	0.5 Hz	-	-	-	-

Note: to test all phase combinations, a small Doppler is inserted. Impact being the test should run for at least 20 seconds.

ATSC A/74 [10] may also be used by picking outer edge points and 2 inner points.

A.2 BRAZIL ENSEMBLES

A.2.1 Brazil E

Table A.2.1 Brazil E Ensemble

Path	Path 1	Path 2	Path 3	Path 4	Path 5	Path 6
Profile	Const Φ	Const Φ	Const Φ	N/A	N/A	N/A
Path Loss (dB)	0.0	0.0	0.05	-	-	-
Delay (μ sec)	0.0	1.0	2.0	-	-	-
Phase ($^{\circ}$ deg)	0.0	0.5 Hz	0.0	-	-	-

Note: to test all phase combinations, a small Doppler is inserted. Impact being the test should run for at least 20 seconds.

Also to avoid total cancelation, one path is reduced 0.05 dB (Path 3).

A.2.2 Brazil C Modified

Table A.2.2 Brazil C Modified Ensemble

Path	Path 1	Path 2	Path 3	Path 4	Path 5	Path 6
Profile	Const Φ	Const Φ	Const Φ	Doppler	Const Φ	Const Φ
Path Loss (dB)	2.8	0.0	3.8	Variable	2.5	1.3
Delay (μ sec)	0.0	0.089	0.419	1.506	2.322	2.799
Phase ($^{\circ}$ deg or Hz)	0.0	0.0	0.0	0.05Hz	0.0	0.0

A.3 COMMUNICATIONS RESEARCH CENTRE CANADA (CRC) ENSEMBLES

A.3.1 CRC Modified #1 (5 Hz)

Table A.3.1 CRC Modified #1 (5 Hz)

Path	Path 1	Path 2	Path 3	Path 4	Path 5	Path 6
Profile	Const Φ	Const Φ	Const Φ	Const Φ	Doppler	Const Φ
Path Loss (dB)	0.0	15.0	15.0	7.0	7.0	15.0
Delay (μ sec)	0.0	-1.8	0.15	1.8	5.7	39.8
Phase ($^{\circ}$ deg or Hz)	0.0	125.0	80.0	45.0	5Hz	90.0

A.3.2 CRC Modified #2 (5 Hz)

Table A.3.2 CRC Modified #2 (5 Hz)

Path	Path 1	Path 2	Path 3	Path 4	Path 5	Path 6
Profile	Const Φ	Const Φ	Const Φ	Const Φ	Doppler	Const Φ
Path Loss (dB)	0.0	8.0	3.0	4.0	3.0	12.0
Delay (μ sec)	0.0	-1.8	0.15	1.8	5.7	39.8
Phase ($^{\circ}$ deg or Hz)	0.0	125.0	80.0	45.0	5Hz	90.0

A.3.3 CRC Modified #3 (5 Hz)

Table A.3.3 CRC Modified #3 (5 Hz)

Path	Path 1	Path 2	Path 3	Path 4	Path 5	Path 6
Profile	Const Φ	Const Φ	Const Φ	Const Φ	Doppler	Const Φ
Path Loss (dB)	0.0	3.0	1.0	1.0	3.0	9.0
Delay (μ sec)	0.0	-1.8	0.15	1.8	5.7	39.8
Phase ($^{\circ}$ deg or Hz)	0.0	125.0	80.0	45.0	5Hz	90.0

A.4 RAYLEIGH ENSEMBLES

Frequency – Wavelength conversion equation

$$f = \frac{c}{\lambda}; c = \text{speed of light } (3 \times 10^8 \text{ m/s})$$

Step 1: Find wavelength of RF carrier:

$$\text{Wavelength } (\lambda) = c(\text{m/s}) / f(\text{Hz}) = 3 \times 10^8 (\text{m/s}) / \lambda(\text{m})$$

$$\text{Wavelength } (\lambda) = 1.6949 \text{ meters}$$

Step 2: Convert speed S of 3 km/hr to Doppler Hz with that found RF wavelength:

$$\text{Doppler(Hz)} = S(\text{m/sec}) / \lambda(\text{m}) = 3000(\text{m})/3600(\text{sec}) / 1.6949(\text{m})$$

$$\text{Doppler(Hz)} = 0.4917 \text{ Hz}$$

A.4.1 Single Path Rayleigh

A speed of 3 km/hr at RF high VHF channel of 177 MHz results in a Doppler of 0.4917 Hz, rounding up to 0.5 Hz.

Table A.4.1 Single Path Rayleigh

Path	Path 1	Path 2	Path 3	Path 4	Path 5	Path 6
Profile	Doppler	N/A	N/A	N/A	N/A	N/A
Path Loss (dB)	0.0	N/A	N/A	N/A	N/A	N/A
Delay (μ sec)	0.0	N/A	N/A	N/A	N/A	N/A
Phase (Hz)	0.5 Hz	N/A	N/A	N/A	N/A	N/A

A.5 TYPICAL URBAN ENSEMBLE

A.5.1 TU-6

A speed of 200 km/hr at RF UHF channel of 695 MHz results in a Doppler of 128.6903 Hz, rounding up to 129 Hz.

Table A.5.1 TU-6 Ensemble

Path	Path 1	Path 2	Path 3	Path 4	Path 5	Path 6
Profile	Rayleigh	Rayleigh	Rayleigh	Rayleigh	Rayleigh	Rayleigh
Path Loss (dB)	3.0	0.0	2.0	6.0	8.0	10.0
Delay (μ sec)	0.0	0.2	0.5	1.6	2.3	5.0
Phase (Hz)	129 Hz	129 Hz	129 Hz	129 Hz	129 Hz	129 Hz

A.6 HANDHELD ENSEMBLES

Ensembles come directly from DVB-H Implementation Guide. A speed of 1.69 km/hr at RF of 695 MHz results in a Doppler of 1.0873 Hz, rounding up to 1.1 Hz. This Doppler is applicable to both Portable Indoor and Portable Outdoor Ensembles.

A.6.1 Portable Indoor Ensemble

Table A.6.1 Portable Indoor Ensemble

Path	1	2	3	4	5	6	7	8	9	10	11	12
Profile	Gauss	Gauss	Gauss	Gauss	Gauss	Gauss	Gauss	Gauss	Gauss	Gauss	Gauss	Gauss
Path Power (dB)	0	-6.4	-10.4	-13.3	-13.3	-13.7	-16.2	-15.2	-14.9	-16.2	-11.1	-11.2
Delay (μ sec)	0.0	0.1	0.2	0.4	0.6	0.8	1.0	1.6	8.1	8.8	9.0	9.2
Phase (Hz)	1.1 Hz	1.1 Hz	1.1 Hz	1.1 Hz	1.1 Hz	1.1 Hz	1.1 Hz	1.1 Hz	1.1 Hz	1.1 Hz	1.1 Hz	1.1 Hz

A.6.3 Portable Outdoor Ensemble

Table A.6.2 Portable Outdoor Ensemble

Path	1	2	3	4	5	6	7	8	9	10	11	12
Profile	Gauss	Gauss	Gauss	Gauss	Gauss	Gauss	Gauss	Gauss	Gauss	Gauss	Gauss	Gauss
Path Power (dB)	0	-1.5	-3.8	-7.3	-9.8	-13.3	-15.9	-20.6	-19.0	-17.7	-18.9	-19.3
Delay (μ sec)	0.0	0.2	0.6	1.0	1.4	1.8	2.3	3.4	4.5	5.0	5.3	5.7
Phase (Hz)	1.1 Hz	1.1 Hz	1.1 Hz	1.1 Hz	1.1 Hz	1.1 Hz	1.1 Hz	1.1 Hz	1.1 Hz	1.1 Hz	1.1 Hz	1.1 Hz

A.7 PEDESTRIAN ENSEMBLES

A speed of 3 km/hr at RF of 695 MHz results in a Doppler of 1.9303 Hz, rounding up to 2 Hz. This can be applied to Pedestrian A and Pedestrian B channel models.

A.7.1 Pedestrian A Ensemble

Table A.7.1 Pedestrian A Ensemble

Path	Path 1	Path 2	Path 3	Path 4	Path 5	Path 6
Profile	Rayleigh	Rayleigh	Rayleigh	Rayleigh	N/A	N/A
Path Power (dB)	0.0	-9.7	-19.2	-22.8	N/A	N/A
Delay (μ sec)	0.0	0.11	0.19	0.41	N/A	N/A
Phase (Hz)	2 Hz	2 Hz	2 Hz	2 Hz	N/A	N/A

A.7.2 Pedestrian B Ensemble

A speed of 3 km/hr at RF of 695 MHz results in a Doppler of 1.9303 Hz, rounding up to 2 Hz. This can be applied to Pedestrian A and Pedestrian B channel models.

Table A.7.2 Pedestrian B Ensemble

Path	Path 1	Path 2	Path 3	Path 4	Path 5	Path 6
Profile	Rayleigh	Rayleigh	Rayleigh	Rayleigh	Rayleigh	Rayleigh
Path Power (dB)	0.0	-0.9	-4.9	-8.0	-7.8	-23.9
Delay (μ sec)	0.0	0.2	0.8	1.2	2.3	3.7
Phase (Hz)	2 Hz	2 Hz	2 Hz	2 Hz	2 Hz	2 Hz

A.8 VEHICULAR ENSEMBLES

A.8.1 Vehicular A Ensemble

A speed of 120 km/hr at RF of 695 MHz results in a Doppler of 77.2140 Hz, rounding up to 77.3 Hz. This can be applied to both Vehicular A and Vehicular B channel models.

Table A.8.1 Vehicular A Ensemble

Path	Path 1	Path 2	Path 3	Path 4	Path 5	Path 6
Profile	Rayleigh	Rayleigh	Rayleigh	Rayleigh	Rayleigh	Rayleigh
Path Power (dB)	0.0	-1.0	-9.0	-10.0	-15.0	-20.0
Delay (μ sec)	0.0	0.31	0.71	1.09	1.73	2.51
Phase(Hz)	77.3 Hz	77.3 Hz	77.3 Hz	77.3 Hz	77.3 Hz	77.3 Hz

A.8.2 Vehicular B Ensemble

Table A.8.2 Vehicular B Ensemble

Path	Path 1	Path 2	Path 3	Path 4	Path 5	Path 6
Profile	Rayleigh	Rayleigh	Rayleigh	Rayleigh	Rayleigh	Rayleigh
Path Power (dB)	-2.5	0.0	-12.8	-10.0	-25.2	-16.0
Delay (μ sec)	0.0	0.3	8.9	12.9	17.1	20.0
Phase(Hz)	77.3 Hz	77.3 Hz	77.3 Hz	77.3 Hz	77.3 Hz	77.3 Hz

A.9 ATSC ENSEMBLES

A.9.1 ATSC R1 Static Dynamic Echo Ensemble

Table A.9.1 ATSC R1 Ensemble

Path	Path 1	Path 2	Path 3	Path 4	Path 5	Path 6
Profile	Gaussian	Gaussian	Gaussian	N/A	N/A	N/A
Path Power (dB)	0.0	Variable (-7 \rightarrow 0)	Identical Path2	N/A	N/A	N/A
Delay (μ sec)	0.0	Variable (0 \rightarrow 2)	Identical Path 2	N/A	N/A	N/A
Phase(Hz)	0.0 Hz	0.05 Hz	Variable (0 \rightarrow 2) Hz	N/A	N/A	N/A

A.9.2 ATSC R2.1 Multiple Dynamic Echo Ensemble

Table A.9.2 ATSC R2.1 Ensemble

Path	Path 1	Path 2	Path 3	Path 4	Path 5	Path 6
Profile	Gaussian	Gaussian	Gaussian	Gaussian	Gaussian	Gaussian
Path Power (dB)	0.0	-11	-11	-1	Variable	-9
Delay (μ sec)	0.0	-1.8	0.15	1.8	5.7	35.0
Phase($^{\circ}$ or Hz)	0.0 $^{\circ}$	125 $^{\circ}$	80 $^{\circ}$	45 $^{\circ}$	Variable (0 \rightarrow 5 Hz)	90 $^{\circ}$

A.9.3 ATSC R2.2 Multiple Dynamic Echo Ensemble

Table A.9.3 ATSC R2.2 Ensemble

Path	Path 1	Path 2	Path 3	Path 4	Path 5	Path 6
Profile	Gaussian	Gaussian	Gaussian	Gaussian	Gaussian	Gaussian
Path Power (dB)	0.0	-3	-1	-1	-3	-9
Delay (μ sec)	0.0	-1.8	0.15	1.8	5.7	39.8
Phase($^{\circ}$ or Hz)	0.0 $^{\circ}$	125 $^{\circ}$	80 $^{\circ}$	45 $^{\circ}$	Variable (0 \rightarrow 5 Hz)	90 $^{\circ}$

Annex B: Example Configuration Settings

B.1 DEVICE UNDER TEST CONFIGURATIONS

Table B.1.1 Example DUT Configurations

	Parameter	Configuration 1	Configuration 2	Configuration 3	Configuration 4	Configuration 5	Configuration 6
Tuner	RF Out Center Frequency	Demodulator IF input	Demodulator IF input	Demodulator IF input	Demodulator IF input	Demodulator IF input	569.0 MHz (Channel 30)
Bootstrap Signaling	Channel Bandwidth	6 MHz	6 MHz	6 MHz	6 MHz	6 MHz	6 MHz
	Sample Rate	6.912 MHz	6.912 MHz	6.912 MHz	6.912 MHz	6.912 MHz	6.912 MHz
Input Formatting	ALP Packet Length	1200 byte $2^{23}-1$ PRBS +8byte UDP Header +20byte IPv4 Header +2byte ALP Header	1200 byte $2^{23}-1$ PRBS +8byte UDP Header +20byte IPv4 Header +2byte ALP Header	1200 byte $2^{23}-1$ PRBS +8byte UDP Header +20byte IPv4 Header +2byte ALP Header	1200 byte $2^{23}-1$ PRBS +8byte UDP Header +20byte IPv4 Header +2byte ALP Header	1200 byte $2^{23}-1$ PRBS +8byte UDP Header +20byte IPv4 Header +2byte ALP Header	1200 byte $2^{23}-1$ PRBS +8byte UDP Header +20byte IPv4 Header +2byte ALP Header
	Baseband Packet Length (K_{payload})	47328 bits	PLP 0: 21408 bits PLP 1: 47328 bits	PLP 0: 21408 bits PLP 1: 25728 bits	21408 bits	43008 bits	1992 bits
BICM Parameters	PLP FEC type	BCH + 64800 LDPC	PLP 0: BCH+64800 LDPC PLP 1: BCH+64800 LDPC	PLP 0: BCH+64800 LDPC PLP 1: BCH+64800 LDPC	BCH + 64800 LDPC	BCH + 64800 LDPC	BCH + 16200 LDPC
	PLP FEC Codelength	64800	PLP 0: 64800 PLP 1: 64800	PLP 0: 64800 PLP 1: 64800	PLP 0: 64800	64800	16200
	PLP Code Rate	11/15	PLP 0: 5/15 PLP 1: 11/15	PLP 0: 5/15 PLP 1: 6/15	5/15	10/15	2/15
	PLP Modulation (QAM NUC)	16	PLP 0: QPSK PLP 1: 64	PLP 0: QPSK (core PLP) PLP 1: 16 (Enhanced PLP)	16	256	QPSK
	PLP Size	1440472	PLP 0: 226800 PLP 1: 1198800	PLP 0: 1355209 PLP 1: 1355209	1133237	1440472	1133237

	Parameter	Configuration 1	Configuration 2	Configuration 3	Configuration 4	Configuration 5	Configuration 6
	PLP Time Interleaver mode	Convolutional	Hybrid	Convolutional	Convolutional	Convolutional	Convolutional
	PLP CTI Depth	1024 rows non-extended		1024 rows non-extended	1024 rows non-extended	1024 rows non-extended	1024 rows non-extended
	PLP CTI Memory ⁴ [cells]	523776		523776	523776	523776	523776
	PLP HTI inter sub-frame		PLP 0: 0 PLP 1: 0				
	PLP HTI # TI Blocks		PLP 0: 1 PLP 1: 6				
	PLP HTI # Max FEC Blocks		PLP 0: 7 PLP 1: 111				
	PLP HTI # FEC Blocks		PLP 0: 7 PLP 1: 111				
	PLP HTI Memory ⁵ [cells]		PLP 0: 291600 PLP 1: 226800				
	PLP HTI Cell interleaver		PLP 0: On PLP 1: On				
OFDM parameters	Frame Length Mode	Symbol-aligned	Symbol-aligned	Symbol-aligned	Time-aligned	Symbol-aligned	Symbol-aligned
	# Sub Frames	1	1	1	1	1	1
	# PLPs	1	2	2	1	1	1
	LDM	off	off	on	off	Off	Off
	LDM injection level	0	0	-4 dB	0	0	0
	Channel Bonding	Off	Off	Off	Off	Off	Off
	MIMO/MISO/SISO	Subframe 1: SISO	Subframe 1: SISO	Subframe 1: SISO	Subframe 1: SISO	Subframe 1: SISO	Subframe 1: SISO
	FFT Size	Subframe 1: 32K	Subframe 1: 32K	Subframe 1: 16K	Subframe 1: 8K	Subframe 1: 32K	Subframe 1: 8K

⁴ Convolutional Time Interleaver (CTI) memory = # rows * (# rows – 1)/2[cells]; CTI depth = # rows² cells

⁵ Hybrid Time Interleaver (HTI) depth = Block interleaver memory + Convolutional interleaver memory

Block Interleaver memory = #rows * #FEC blocks = (LDPC codelength/log2(modulation)) * #FEC blocks)

Convolutional Interleaver memory = ((#rows/#TI blocks+1) * #FEC blocks) * (#TI blocks * (# TI blocks -1)/2)

HTI depth = (#rows * #FEC blocks)+(((#rows/#TI blocks+1) * #FEC blocks) * (#TI blocks * (# TI blocks -1)/2))*2+1)[cells]

Time Interleaver depth = (#symbols/sub-frame) * (FFT size / (Baseband Sample Rate(BSR) / #PLPs)) * (1+GI Ratio)

Time Interleaver depth = (Interleaver depth [cells] / NoC) * (FFT size/(BSR / #PLPs)) * (1+GI ratio)

	Parameter	Configuration 1	Configuration 2	Configuration 3	Configuration 4	Configuration 5	Configuration 6
	Guard Interval	Subframe 1: GI5_1024(148μsec)	Subframe 1: GI5_1024(148μsec)	Subframe 1: GI5_1024(148μsec)	Subframe 1: GI6_1536(222μsec)	Subframe 1: GI5_1024(148μsec)	Subframe 1: GI6_1536(222μsec)
	NoC (# of data carriers)	Subframe 1: 27649 (reduced carriers =0)	Subframe 1: 27649 (reduced carriers =0)	Subframe 1: 13825 (reduced carriers =0)	Subframe 1: 6913 (reduced carriers =0)	Subframe 1: 27649 (reduced carriers =0)	Subframe 1: 6913 (reduced carriers =0)
	Scattered Pilot Pattern	Subframe 1: SP24_2	Subframe 1: SP24_2	Subframe 1: SP6_2	Subframe 1: SP4_2	Subframe 1: SP24_2	Subframe 1: SP4_2
	SP boost	Subframe 1: 2.43	Subframe 1: 2.43	Subframe 1: 1.7	Subframe 1: 1.51	Subframe 1: 2.43	Subframe 1: 1.51
	# Payload Symbols	Subframe 1: 53	Subframe 1: 53	Subframe 1: 108	Subframe 1: 189	Subframe 1: 53	Subframe 1: 189
	Subframe Length	Subframe 1: 264.0 msec	Subframe 1: 264.0 msec	Subframe 1: 272.0 msec	Subframe 1: 275.0 msec	Subframe 1: 264.0 msec	Subframe 1: 266.0 msec
	First Subframe Boundary Symbol	Subframe 1: Yes	Subframe 1: Yes	Subframe 1: Yes	Subframe 1: Yes	Subframe 1: Yes	Subframe 1: Yes
	Last Subframe Boundary Symbol	Subframe 1: Yes	Subframe 1: Yes	Subframe 1: Yes	Subframe 1: Yes	Subframe 1: Yes	Subframe 1: Yes
	PLP Multiplexing ⁶	Subframe 1: TDM	Subframe 1: TDM	Subframe 1: LDM	Subframe 1: TDM	Subframe 1: TDM	Subframe 1: TDM
	Channel Occupancy (Scheduler regulated)	Subframe 1: 100%	Subframe 1, PLP 0: 18% Subframe 1, PLP 1: 82%	Subframe 1: 100%	Subframe 1: 100%	Subframe 1: 100%	Subframe 1: 100%
	Frequency Interleaver	On	On	On	On	On	On
	PAPR	Off	Off	Off	Off	Off	Off
Preamble Parameters	L1 Basic Mode	Mode 3	Mode 1	Mode 1	Mode 1	Mode 3	Mode 1
	L1 Detail Mode	Mode 3	Mode 1	Mode 1	Mode 1	Mode 3	Mode 1
	FFT	32K	32K	16K	8K	32K	8K
	Reduced Carriers	0	0	0	0	0	0
	Guard Interval	GI5_1024	GI5_1024	GI5_1024	GI6_1536	GI5_1024	GI6_1536
	SP_Dx	12	12	6	4	12	4
	# Preamble Symbols	1	1	1	2	1	2
Performance	Data Rate (Mbps)	15.815	PLP 0: 0.6322 PLP 1: 19.3932	PLP 0: 3.2384 PLP 1: 7.7837	5.44	28.7612	1.0298
	Required theoretical SNR under AWGN channel (dB)	9.8	PLP 0: -1.3 PLP 1: 14.7	PLP 0: 1.7 PLP 1: 10.3	3.4	17.5	-4.9

⁶ PLP_ID, PLP_Size, PLP_Type, PLP_Start, Num_subsllices and subslice_Interval settings may vary.

	Parameter	Configuration 1	Configuration 2	Configuration 3	Configuration 4	Configuration 5	Configuration 6
	(considering power boosting)						

Gray shaded rows are calculation results given by respective parameter choices.

– End of Document –