



The Broadcast[®]
Standards
Association



ATSC Recommended Practice: Guide to the Link-Layer Protocol

A/350:2026-04
14 April 2026

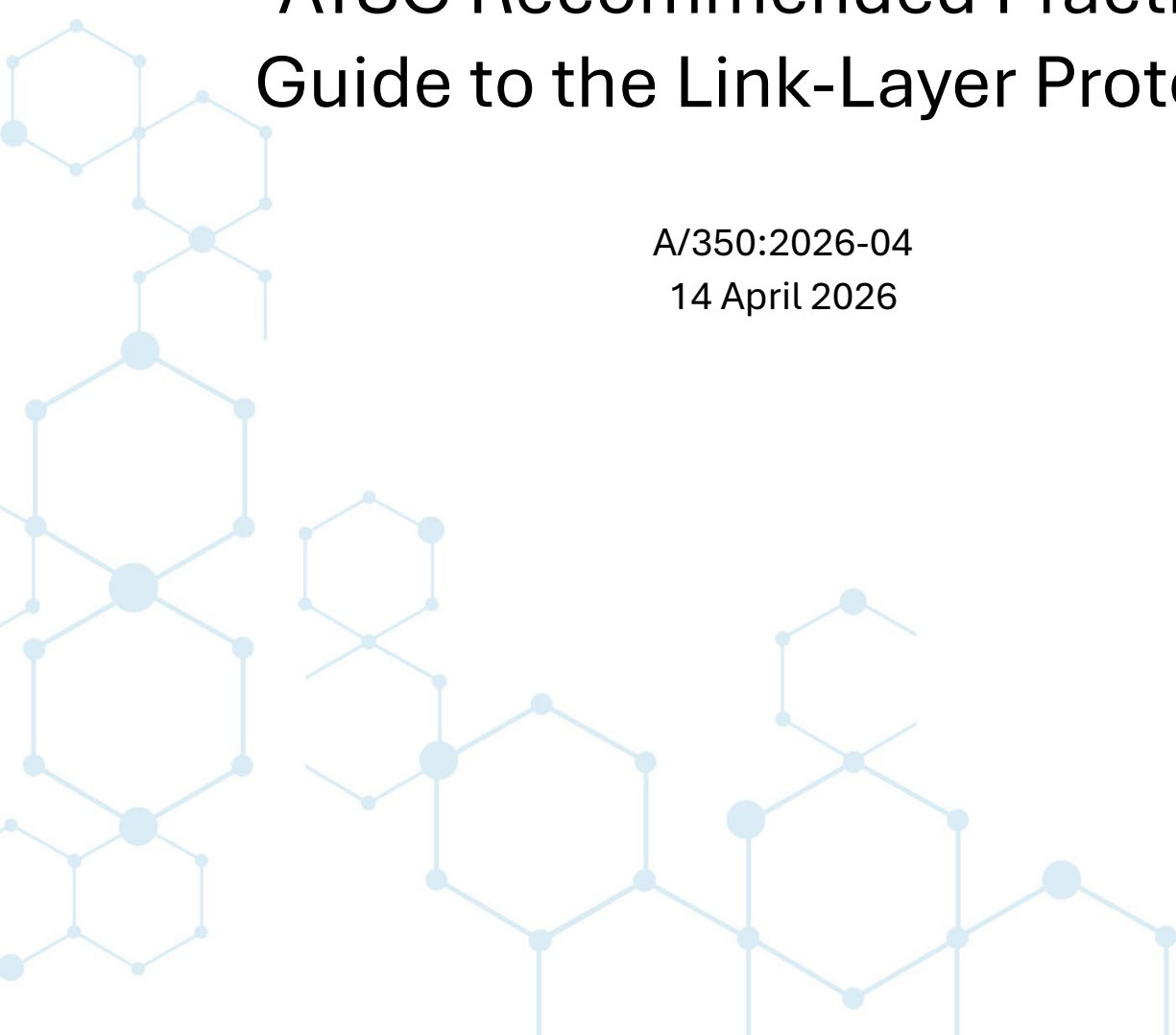

ATSC[®], the Broadcast Standards Association[®], is an international, non-profit organization developing voluntary standards and recommended practices for broadcast television and multimedia data distribution. ATSC member organizations represent the broadcast, professional equipment, motion picture, consumer electronics, computer, cable, satellite, and semiconductor industries. ATSC also develops implementation strategies and supports educational activities on ATSC standards. ATSC was formed in 1983 by the member organizations of the Joint Committee on Inter-society Coordination (JCIC): the Consumer Technology Association (CTA), the Institute of Electrical and Electronics Engineers (IEEE), the National Association of Broadcasters (NAB), the Internet & Television Association (NCTA), and the Society of Motion Picture and Television Engineers (SMPTE). For more information visit www.atsc.org.

© Copyright 2026 ATSC. All rights reserved.

Note: The user's attention is called to the possibility that compliance with this recommended practice may require use of an invention covered by patent rights. By publication of this standard, no position is taken with respect to the validity of this claim or of any patent rights in connection therewith. One or more patent holders have, however, filed a statement regarding the terms on which such patent holder(s) may be willing to grant a license under these rights to individuals or entities desiring to obtain such a license. Details may be obtained from the ATSC Secretary and the patent holder.

Implementers with feedback, comments, or potential bug reports relating to this document may contact ATSC at <https://www.atsc.org/feedback/>.

Revision History

Version	Date
A/350 Recommended Practice approved	19 July 2019
A/350:2022-03 (references to ATSC documents updated)	31 March 2022
A/350:2023-03 (references to ATSC documents updated)	28 March 2023
A/350:2024-04 (references to ATSC documents updated)	3 April 2024
A/350:2025-07 (references to ATSC documents updated)	17 July 2025
A/350:2026-04 (references to ATSC documents updated)	14 April 2026

Table of Contents

1. SCOPE	1
1.1 Organization	1
2. REFERENCES	1
2.1 Informative References	1
3. DEFINITION OF TERMS	2
3.1 Compliance Notation	2
3.2 Treatment of Syntactic Elements	2
3.2.1 Reserved Elements	2
3.3 Acronyms and Abbreviations	2
3.4 Terms	3
3.5 Extensibility	4
4. OVERVIEW	4
4.1 System Architecture	4
5. GUIDELINES FOR IP HEADER COMPRESSION	6
5.1 IP Stream Classification Guidelines for ROHC	8
5.1.1 IP Stream Classification	8
5.1.2 Assignment of Context ID	8
5.2 Recommendations for ROHC Encoding	8
5.2.1 IP-ID Encoding	8
5.3 Recommendations for Selection of Adaptation Mode	9
5.3.1 IP Stream for Adaptation Mode 1	9
5.3.2 IP Stream for Adaptation Modes 2 and 3	9
5.4 RDT Transmission	10
5.4.1 RDT Generation	10
5.4.2 RDT Transmission Mode Selection	11
5.4.3 ROHC Initialization and Refresh	11
5.4.4 RDT Retransmission	11
6. RECOMMENDATIONS FOR PACKET ENCAPSULATION	11
6.1 LMT Encapsulation	11
6.2 RDT Encapsulation	11
6.2.1 Encapsulation of Catalog RDT	11
7. GUIDELINES FOR IP HEADER DECOMPRESSION	12
7.1 Synchronization Between RDT and Compressed Packet Flows	12
7.1.1 RDT Synchronization in Receiver for Adaptation Mode 2	13
7.1.2 RDT Synchronization in Receiver for Adaptation Mode 3	15
7.1.3 Decompression Start without RDT Synchronization for Adaptation Mode 3	17
7.2 Guidelines for ROHC Decoding	19
7.2.1 Determination of IP-ID Behavior	19
ANNEX A : INTEROPERABILITY FUNCTIONAL TESTS	20
A.1 Test Cases	20

Index of Figures

Figure 4.1 ALP system architecture and internal identifiers.	5
Figure 5.1 Functional structure for IP header compression.	6
Figure 5.2 Combined structure for IP header compression in ATSC 3.0.	7
Figure 5.3 Example capture of input IP stream for adaptation mode 3.	10
Figure 6.1 Example of ALP signaling packet with Catalog RDT.	12

Index of Tables

Table 7.1 Example of IP/UDP Stream for IP Header Compression	13
Table 7.2 Example of Compressed IP Stream (Adaptation Mode 2)	14
Table 7.3 Example of Static Chain for RDT	15
Table 7.4 Example of Compressed IP Stream (Adaptation Mode 3)	16
Table 7.5 Example of Static Chain and Dynamic Chain for RDT	17
Table 7.6 Example of CRC Check of Compressed Header	17
Table 7.7 Example of IP Header Compression (Without UDP Checksum)	18
Table 7.8 Example of Static Chain and Dynamic Chain for RDT	19
Table A.1.1 List of Interoperability Functional Tests	20

ATSC Recommended Practice: Guide to the Link-Layer Protocol

1. SCOPE

This document provides recommended practices for the ATSC Link-layer Protocol (ALP) standard specified by A/330 [1].

1.1 Organization

This document is organized as follows:

- Section 1 – Outlines the scope of this document and provides a general introduction.
- Section 2 – Lists references and applicable documents.
- Section 3 – Provides a definition of terms, acronyms, and abbreviations for this document.
- Section 4 – Overview of ALP system.
- Section 5 – Guidelines for IP Header Compression.
- Section 6 – Recommendations for Packet Encapsulation.
- Section 7 – Guidelines for IP Header Decompression.
- Annex A – Interoperability Functional Tests.

2. REFERENCES

All referenced documents are subject to revision. Users of this Standard are cautioned that newer editions might or might not be compatible.

2.1 Informative References

The following documents contain information that may be helpful in applying this Recommended Practice.

- [1] ATSC: “ATSC Standard: Link-Layer Protocol,” Doc. A/330:2026-04, ATSC, Washington, DC, 14 April 2026.
- [2] ATSC: “ATSC Standard: Physical Layer Protocol,” Doc. A/322:2026-04, ATSC, Washington, DC, 14 April 2026.
- [3] ATSC: “ATSC Standard: Signaling, Delivery, Synchronization, and Error Protection,” Doc. A/331:2026-04, ATSC, Washington, DC, 14 April 2026.
- [4] IEEE: “Use of the International Systems of Units (SI): The Modern Metric System,” Doc. SI 10, Institute of Electrical and Electronics Engineers, New York, NY.
- [5] IETF: “Internet Protocol,” Doc. STD05 (originally RFC 791), Internet Engineering Task Force, Reston, VA, September 1981.
- [6] IETF: “User Datagram Protocol,” Doc. STD06 (originally RFC 768), Internet Engineering Task Force, Reston, VA, August 1980.
- [7] IETF: RFC 3095: “RObust Header Compression (ROHC): Framework and four profiles: RTP, UDP, ESP, and uncompressed”, Internet Engineering Task Force, Reston, VA, July 2001
<http://tools.ietf.org/html/rfc3095>
- [8] IETF: RFC 4815: “RObust Header Compression (ROHC): Corrections and Clarifications to RFC 3095”, Internet Engineering Task Force, Reston, VA, February 2007.
<http://tools.ietf.org/html/rfc4815>

[9] IETF: RFC 5795: “The ROBust Header Compression (ROHC) Framework”, Internet Engineering Task Force, Reston, VA, March 2010.
<http://tools.ietf.org/html/rfc5795>

3. DEFINITION OF TERMS

With respect to definition of terms, abbreviations, and units, the practice of the Institute of Electrical and Electronics Engineers (IEEE) as outlined in the Institute’s published standards [4] should be used. Where an abbreviation is not covered by IEEE practice or industry practice differs from IEEE practice, the abbreviation in question will be described in Section 3.3 of this document.

3.1 Compliance Notation

This section defines compliance terms for use by this document:

should – This word indicates that a certain course of action is preferred but not necessarily required.

should not – This phrase means a certain possibility or course of action is undesirable but not prohibited.

3.2 Treatment of Syntactic Elements

This document contains symbolic references to syntactic elements used in the audio, video, and transport coding subsystems. These references are typographically distinguished by the use of a different font (e.g., `restricted`), may contain the underscore character (e.g., `sequence_end_code`) and may consist of character strings that are not English words (e.g., `dynrng`).

3.2.1 Reserved Elements

One or more reserved bits, symbols, fields, or ranges of values (i.e., elements) may be present in this document. These are used primarily to enable adding new values to a syntactical structure without altering its syntax or causing a problem with backwards compatibility, but they also can be used for other reasons.

The ATSC default value for reserved bits is ‘1’. There is no default value for other reserved elements. Use of reserved elements except as defined in ATSC Standards or by an industry standards setting body is not permitted. See individual element semantics for mandatory settings and any additional use constraints. As currently-reserved elements may be assigned values and meanings in future versions of this Standard, receiving devices built to this version are expected to ignore all values appearing in currently-reserved elements to avoid possible future failure to function as intended.

3.3 Acronyms and Abbreviations

The following acronyms and abbreviations are used within this document.

ALP – ATSC Link-layer Protocol

CID – Context Identifier

CRC – Cyclic Redundancy Check

DF – Don’t Fragment (a flag in IPv4 header)

ID – Identifier

IETF – Internet Engineering Task Force

IP – Internet Protocol

IPv4 – Internet Protocol version 4

IR – Initialization and Refresh
IR-DYN – IR Dynamic
LLS – Low Level Signaling
LMT – Link Mapping Table
LSB – Least Significant Bit
MPEG – Moving Picture Experts Group
MSB – Most Significant Bit
PHY – PHYsical (layer)
PID – Packet Identifier
PLP – Physical Layer Pipe
RAP – Random Access Point
RDT – ROHC-U Description Table
RF – Radio Frequency
RFC – Request For Comment (IETF standard)
ROHC – RObust Header Compression
ROHC-U – ROHC–Unidirectional mode
SID – Sub-stream IDentifier
SN – Sequence Number
TS – Transport Stream
TV - TeleVision
UDP – User Datagram Protocol

3.4 Terms

The following terms are used within this document.

Additional Header – An Additional Header is part of the ALP packet header. The presence of an Additional Header depends on the specific field values of the Base Header.

Base Header – A Base Header is part of the ALP packet header. A Base Header is always included in the header of an ALP packet and is the first part of an ALP packet.

Broadcast Stream – The abstraction for an RF channel which is defined in terms of a carrier frequency centered within a specified bandwidth.

Catalog RDT – A type of RDT delivery that contains the context data for multiple ROHC/ALP streams and can be carried in a robust signaling PLP. Thus, it can supply multiple RDTs for multiple ALP streams.

Context – RFC 3095 0 describes Context, as used herein, in the following manner: ‘The context of the compressor is the state it uses to compress a header. The context of the decompressor is the state it uses to decompress a header. Either of these or the two in combination are usually referred to as “context,” when it is clear which is intended. The context contains relevant information from previous headers in the packet stream, such as static fields and possible reference values for compression and decompression. Moreover, additional information describing the packet stream is also part of the context, for example information about how the IP Identifier field changes and the typical inter-packet increase in sequence numbers or timestamps.’

Discrete RDT – A type of RDT delivery that is carried exclusively within the ALP stream that it supports. This approach is consistent with RFC 3095 0 (ROHC), wherein the context is always carried within the related IP stream.

Extension Header – An Extension Header is part of the ALP packet header. The presence of an Extension Header depends on the specific field values of the Additional Header.

IP-ID – Identification field of an IPv4 packet.

multicast – (verb) To send data across (e.g., an IPv4) network to many recipients simultaneously; (noun) A set of data sent across (e.g., an IPv4) network to many recipients simultaneously.

Network Layer Packet – A Network Layer Packet is a source packet in the protocol of the data to be transported, e.g., an MPEG-2 Transport Stream packet or an Internet Protocol packet.

Null Packet – An MPEG-2 TS packet with PID equal to 0x1FFF.

Real Time Service RAP – A Real Time Service Random Access Point is defined as a point in the delivery of the data required to start a Real Time Service, at which point a receiver can acquire that Service with minimal delay.

reserved – Set aside for future use by a Standard.

Service – A collection of media components presented to the user in aggregate; the components can be of multiple media types; a Service can be either continuous or intermittent; a Service can be Real Time or Non-Real Time; a Real Time Service can consist of a sequence of TV programs.

3.5 Extensibility

The protocols specified in the present standard are designed with features and mechanisms to support extensibility. Receiving devices are expected to disregard reserved values and unrecognized or unsupported table types.

4. OVERVIEW

4.1 System Architecture

Figure 4.1 shows the ALP system architecture and related identifiers in emission side.

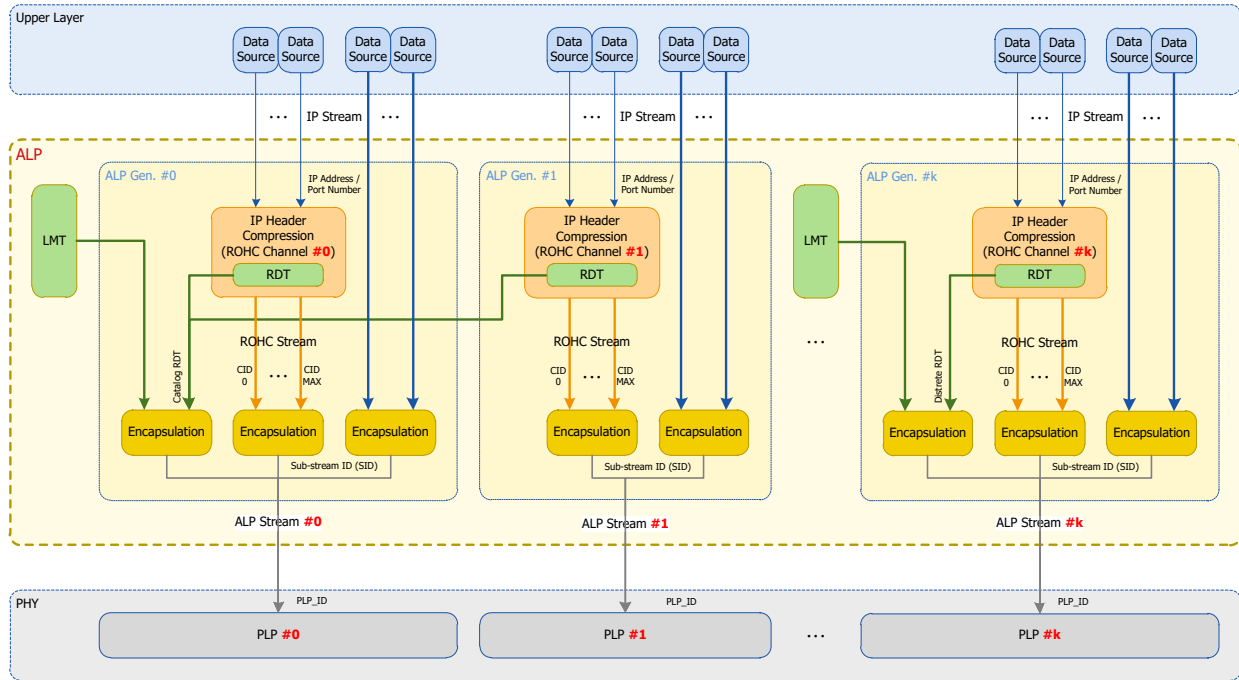

Figure 4.1 ALP system architecture and internal identifiers.

One or more ALP streams can be delivered from an entire ALP generator. However, only a single ALP stream is delivered to each Physical Layer Pipe (PLP). To generate ALP streams, multiple component ALP generators can be configured, with one ALP generator for each ALP stream. The ALP stream from each component ALP generator should be delivered to its unique PLP. Therefore, the PLP ID can be used as the ALP Stream ID and component ALP generator ID.

The RObust Header Compression (ROHC) framework defines channels to identify the compressed packet flow. In ATSC 3.0, a single ROHC channel should be configured in an ALP stream. Therefore, the PLP ID can be mapped to an ROHC channel number.

5. GUIDELINES FOR IP HEADER COMPRESSION

In this section, several guidelines and recommendations are provided for the use of IP header compression.

Figure 5.1 shows the functional structure of the IP header compression mechanism in ALP. Figure 5.1 represents a separate structure between the ROHC module and the adaptation module. This structure can be considered when an existing ROHC solution will be used for implementation.

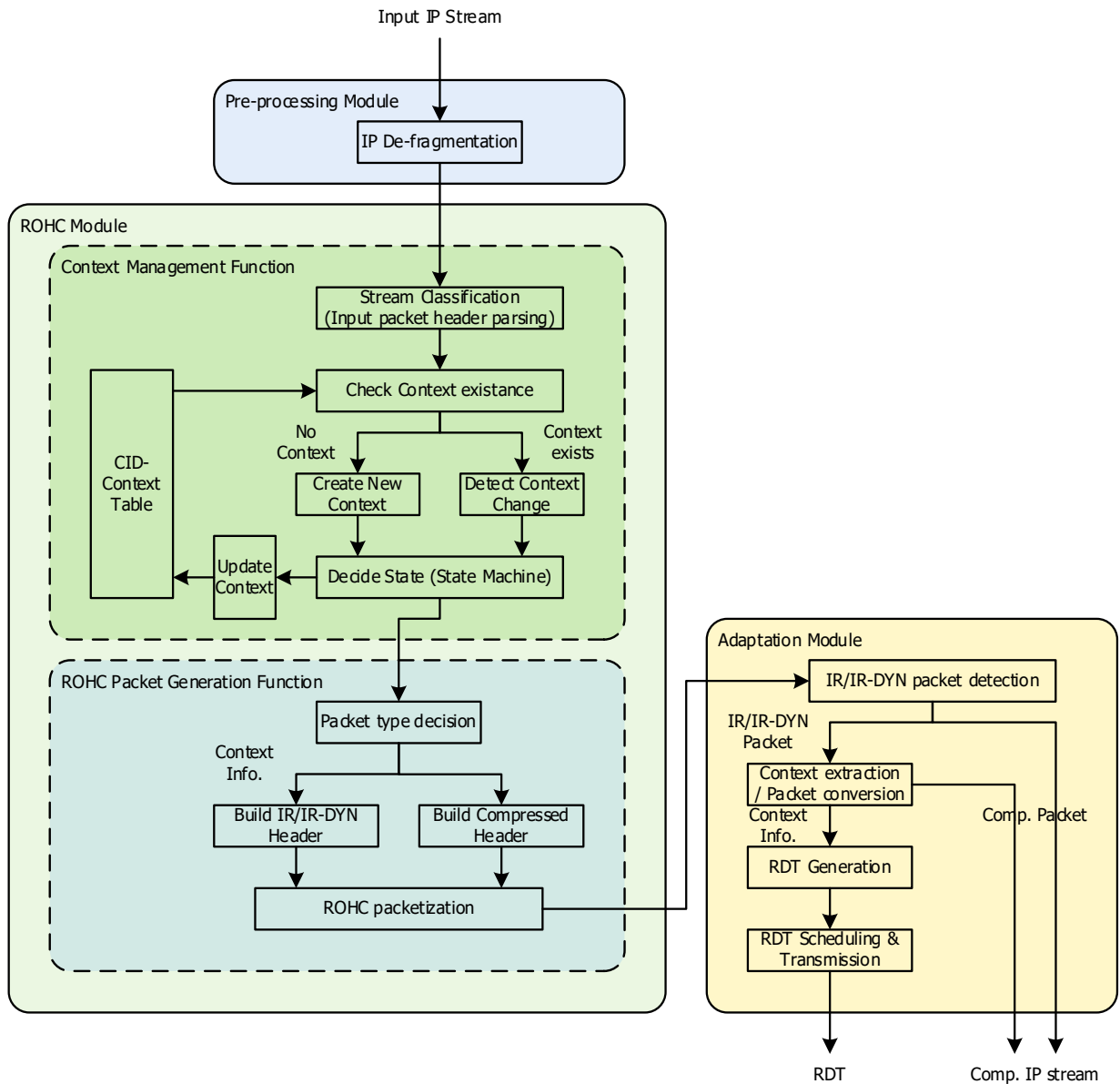

Figure 5.1 Functional structure for IP header compression.

In the ROHC function, when an IP/UDP stream is delivered into a ROHC module, the ROHC compressor will classify each packet stream based on static context information and will assign a Context Identifier (CID). These CIDs will be managed in a CID-Context table. Based on a state machine, each IP/UDP packet header is changed to an Initialization and Refresh (IR) or IR-

Dynamic (IR-DYN) packet or is encoded to a compressed header. The ROHC stream consists of these IR, IR-DYN and compressed packets.

The adaptation module detects the IR and IR-DYN packets from the ROHC packet flow and extracts the context information. The static chain and dynamic chain can be extracted from the IR packets, and the dynamic chain can be extracted from the IR-DYN packets. After extracting the context information, each IR and IR-DYN packet is converted to a compressed packet according to the configured adaptation mode. Each converted compressed packet is included and transmitted inside the ROHC packet flow in the same order as the IR or IR-DYN packet that it replaced. Context information is contained in the ROHC-U Description Table (RDT) which is encapsulated in a link layer signaling packet.

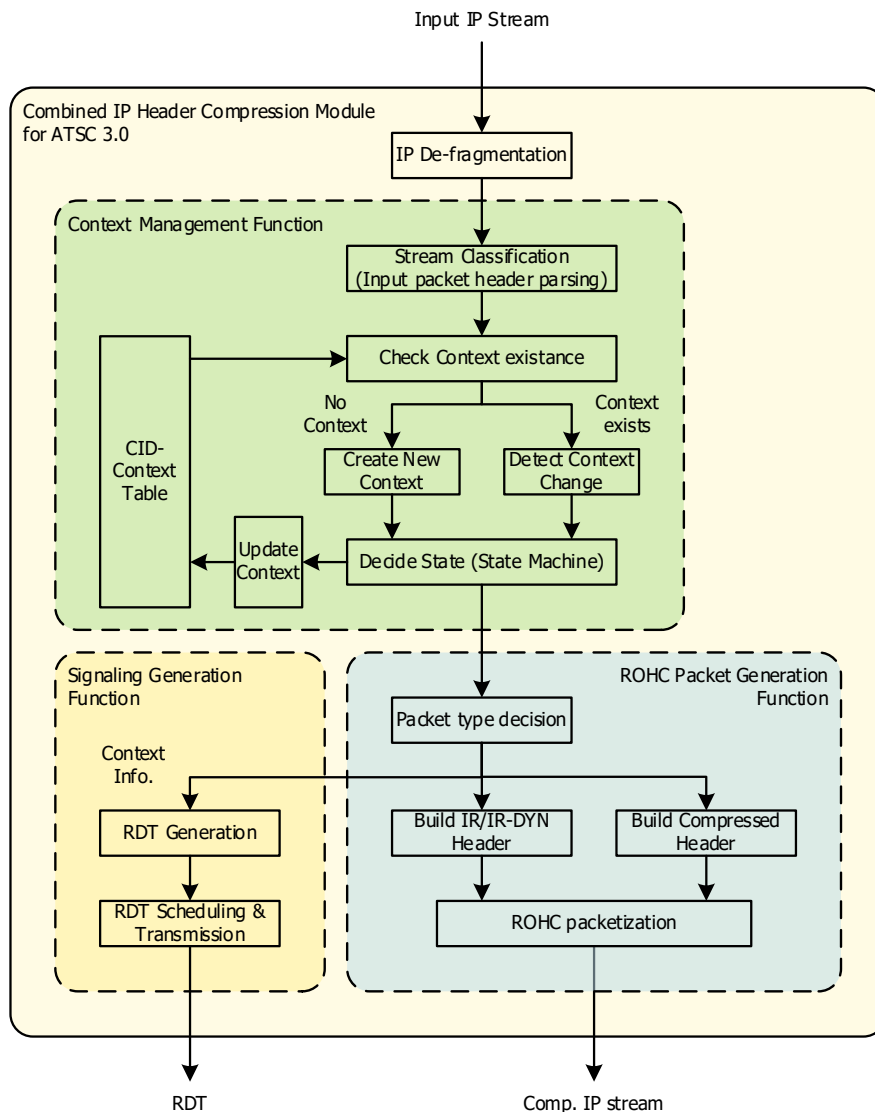

Figure 5.2 Combined structure for IP header compression in ATSC 3.0.

From the implementation point of view, the adaptation module can be merged with the ROHC module. Figure 5.2 shows the combined structure which generates the RDT, including context

information, instead of IR or IR-DYN packet by the ROHC compressor. The adaptation mode configuration determines whether the context information is included in the RDT or ROHC packets. Other than the above exception, the other existing ROHC functionality can be reused.

5.1 IP Stream Classification Guidelines for ROHC

5.1.1 IP Stream Classification

ALP needs to classify the input IP stream (synonymous with the term ‘UDP/IP stream’ also used in this section). In this section, several guidelines for input IP stream classification are provided.

An IP stream should be classified based on the IP address and port number. IP packets can be considered to belong to the same IP stream when all of the IP packets have the same combination of source IP address, destination IP address, source UDP port, and destination UDP port. For the same IP/UDP stream, the same CID should be assigned.

According to the A/331 specification [3], LLS is transported in IP packets with address 224.0.23.60 and destination port number 4937. LLS packets should remain uncompressed.

5.1.2 Assignment of Context ID

As specified in RFC 3095 0, in the ROHC UDP profile (0x0002), each UDP/IP stream is assigned a CID. The same CID should not be assigned to different UDP/IP streams (i.e. static context information). However, the CID for a given UDP/IP stream can optionally be changed. When the CID for a given UDP/IP stream needs to be changed, it is strongly recommended that the CID should be changed during the ROHC compressor’s IR state. The CIDs are distinct for each ROHC channel. For example, CID ‘0’ over ROHC channel 1 and CID ‘0’ over ROHC channel 2 do not refer to the same context.

For packets with a particular CID value, the UDP Sequence Number (UDP SN) generated by the ROHC compressor is required to increment by exactly one for each successive packet in the stream (see RFC 3095 0, Sections 5.11.3 and 5.11.4).

Based on the ROHC packet structure, when there is no CID byte in the ROHC packet, it means that the packet has been assigned CID ‘0’. CID ‘0’ is assigned for the most common UDP/IP stream in each PLP.

5.2 Recommendations for ROHC Encoding

In this section, recommendations and examples of ROHC encoding are provided.

5.2.1 IP-ID Encoding

According to the restriction of the IP-ID field in A/331 [3], it can be considered that there are only two behaviors of IP-ID in the ROHC module; unused IP-ID and sequential IP-ID cases. Random IP-ID should not be used.

5.2.1.1 Unused IP-ID Case

When IP fragmentation is not present, all IP-ID values of incoming IP packets are always ‘0x00’, and the value of the DF field is always ‘1’. In this case, IP-ID is not be encoded in ROHC compressor, and the receiver will not care about the IP-ID field. The context value of IP-ID should be set to ‘0x00’. The context information of IP-ID is never updated. The context value of the DF field in dynamic chain should be set to ‘1’.

5.2.1.2 Sequential IP-ID Case

When IP fragmentation is either present or its presence is unknown, the IP-ID values of incoming IP packets increase monotonically, and the value of the DF field is always '0'. Even though the fragmented packets are reassembled prior to the ROHC module, the IP-ID fields should be compressed. In this case, IP-ID should be encoded with the offset IP-ID encoding scheme. The context of IP-ID should be updated based on the offset IP-ID encoding scheme as specified in RFC 3095 0 Section 4.4.5. The context value of the DF field in dynamic chain shall be set to '0'.

5.3 Recommendations for Selection of Adaptation Mode

This section presents several guidelines about stream classification and context behavior of an IP stream in the selection of the appropriate adaptation mode.

5.3.1 IP Stream for Adaptation Mode 1

In the emission side, when a broadcast channel is configured with a single PLP, and the IP header compression module is implemented as a separate structure such as in the example of Figure 5.1, adaptation mode 1 should be used. Adaptation mode 1 operation is similar to the original operation of ROHC, and all IP streams are acceptable.

5.3.2 IP Stream for Adaptation Modes 2 and 3

In the emission side, when a broadcast channel is configured with a single PLP, and the IP header compression module is implemented as a combined structure such as in the example of Figure 5.2, adaptation mode 2 or 3 can be used. Additionally, for a broadcast service, when a separate signaling PLP is configured, adaptation mode 2 or 3 can be used. In these situations, when the context is updated frequently, adaptation mode 2 can be used. When the context is updated rarely, adaptation mode 3 can be selected.

For an IPv4 stream, if IP address and port number are useful only for such stream, adaptation mode 3 can be selected. Figure 5.3 shows an example of an input IP packet stream. In this IP stream, IP-ID is unused and the dynamic context information never changes except for SN. In this case, adaptation mode 3 can be selected. Adaptation mode 3 is the most efficient among the three adaptation modes.

No.	Time	IPv4 Header											UDP Header				
		V	HL	DiffSrv	Total_Len	Identification	Flags	Frag_Offset	TTL	Protocol	Hdr_Checksum	Src_Addr	Dest_Addr	SP	DP	Length	Checksum
1	0.000000	4	20	0x00	1344	0x0000 (0)	0x02	0	64	UDP	0x2982	10.1...	239.2...	1324	0x54f0
2	0.000254	4	20	0x00	1344	0x0000 (0)	0x02	0	64	UDP	0x2982	10.1...	239.2...	1324	0x925b
3	0.000436	4	20	0x00	1344	0x0000 (0)	0x02	0	64	UDP	0x2982	10.1...	239.2...	1324	0x5e8a
4	0.000676	4	20	0x00	1344	0x0000 (0)	0x02	0	64	UDP	0x2982	10.1...	239.2...	1324	0x3f4e
5	0.000865	4	20	0x00	1344	0x0000 (0)	0x02	0	64	UDP	0x2982	10.1...	239.2...	1324	0x824b
6	0.001055	4	20	0x00	1344	0x0000 (0)	0x02	0	64	UDP	0x2982	10.1...	239.2...	1324	0x1ae7
7	0.001254	4	20	0x00	1344	0x0000 (0)	0x02	0	64	UDP	0x2982	10.1...	239.2...	1324	0x9483
8	0.001441	4	20	0x00	1344	0x0000 (0)	0x02	0	64	UDP	0x2982	10.1...	239.2...	1324	0xf47a
9	0.001638	4	20	0x00	1344	0x0000 (0)	0x02	0	64	UDP	0x2982	10.1...	239.2...	1324	0xa533
10	0.001837	4	20	0x00	1344	0x0000 (0)	0x02	0	64	UDP	0x2982	10.1...	239.2...	1324	0x74de
11	0.002019	4	20	0x00	1344	0x0000 (0)	0x02	0	64	UDP	0x2982	10.1...	239.2...	1324	0x935c
12	0.002200	4	20	0x00	1344	0x0000 (0)	0x02	0	64	UDP	0x2982	10.1...	239.2...	1324	0x8e86
13	0.002399	4	20	0x00	1344	0x0000 (0)	0x02	0	64	UDP	0x2982	10.1...	239.2...	1324	0x5728
14	0.002580	4	20	0x00	1344	0x0000 (0)	0x02	0	64	UDP	0x2982	10.1...	239.2...	1324	0x6bc7
15	0.002758	4	20	0x00	1344	0x0000 (0)	0x02	0	64	UDP	0x2982	10.1...	239.2...	1324	0x9463
16	0.002949	4	20	0x00	1344	0x0000 (0)	0x02	0	64	UDP	0x2982	10.1...	239.2...	1324	0xa22a
17	0.003129	4	20	0x00	1344	0x0000 (0)	0x02	0	64	UDP	0x2982	10.1...	239.2...	1324	0xc822
18	0.003313	4	20	0x00	1344	0x0000 (0)	0x02	0	64	UDP	0x2982	10.1...	239.2...	1324	0x49f4
19	0.003505	4	20	0x00	1344	0x0000 (0)	0x02	0	64	UDP	0x2982	10.1...	239.2...	1324	0x9892
20	0.003686	4	20	0x00	1344	0x0000 (0)	0x02	0	64	UDP	0x2982	10.1...	239.2...	1324	0xd18d
21	0.004443	4	20	0x00	1344	0x0000 (0)	0x02	0	64	UDP	0x2982	10.1...	239.2...	1324	0xe082
22	0.004682	4	20	0x00	1344	0x0000 (0)	0x02	0	64	UDP	0x2982	10.1...	239.2...	1324	0x41b2
23	0.004904	4	20	0x00	1344	0x0000 (0)	0x02	0	64	UDP	0x2982	10.1...	239.2...	1324	0xcfe7
24	0.005088	4	20	0x00	1344	0x0000 (0)	0x02	0	64	UDP	0x2982	10.1...	239.2...	1324	0x3b52
25	0.005291	4	20	0x00	1344	0x0000 (0)	0x02	0	64	UDP	0x2982	10.1...	239.2...	1324	0x23bb
26	0.005473	4	20	0x00	1344	0x0000 (0)	0x02	0	64	UDP	0x2982	10.1...	239.2...	1324	0xb631
27	0.005651	4	20	0x00	1344	0x0000 (0)	0x02	0	64	UDP	0x2982	10.1...	239.2...	1324	0xdd7b
28	0.005843	4	20	0x00	1344	0x0000 (0)	0x02	0	64	UDP	0x2982	10.1...	239.2...	1324	0x5871
29	0.006139	4	20	0x00	1344	0x0000 (0)	0x02	0	64	UDP	0x2982	10.1...	239.2...	1324	0xdeeb
30	0.006316	4	20	0x00	1344	0x0000 (0)	0x02	0	64	UDP	0x2982	10.1...	239.2...	1324	0xb317
31	0.006510	4	20	0x00	1344	0x0000 (0)	0x02	0	64	UDP	0x2982	10.1...	239.2...	1324	0x91f0
32	0.006691	4	20	0x00	1344	0x0000 (0)	0x02	0	64	UDP	0x2982	10.1...	239.2...	1324	0xda39
33	0.006867	4	20	0x00	1344	0x0000 (0)	0x02	0	64	UDP	0x2982	10.1...	239.2...	1324	0x6032
34	0.007055	4	20	0x00	1344	0x0000 (0)	0x02	0	64	UDP	0x2982	10.1...	239.2...	1324	0x10e3
35	0.007233	4	20	0x00	1344	0x0000 (0)	0x02	0	64	UDP	0x2982	10.1...	239.2...	1324	0x42e0
36	0.007408	4	20	0x00	1344	0x0000 (0)	0x02	0	64	UDP	0x2982	10.1...	239.2...	1324	0xb914
37	0.007598	4	20	0x00	1344	0x0000 (0)	0x02	0	64	UDP	0x2982	10.1...	239.2...	1324	0xacfa
38	0.007779	4	20	0x00	1344	0x0000 (0)	0x02	0	64	UDP	0x2982	10.1...	239.2...	1324	0x6cef
39	0.007959	4	20	0x00	1344	0x0000 (0)	0x02	0	64	UDP	0x2982	10.1...	239.2...	1324	0x42ad
40	0.008146	4	20	0x00	1344	0x0000 (0)	0x02	0	64	UDP	0x2982	10.1...	239.2...	1324	0xe8ee
41	0.008323	4	20	0x00	1344	0x0000 (0)	0x02	0	64	UDP	0x2982	10.1...	239.2...	1324	0x32d6
42	0.008499	4	20	0x00	1344	0x0000 (0)	0x02	0	64	UDP	0x2982	10.1...	239.2...	1324	0x5c84
43	0.008690	4	20	0x00	1344	0x0000 (0)	0x02	0	64	UDP	0x2982	10.1...	239.2...	1324	0x670f
44	0.008873	4	20	0x00	1344	0x0000 (0)	0x02	0	64	UDP	0x2982	10.1...	239.2...	1324	0x48b1
45	0.009049	4	20	0x00	1344	0x0000 (0)	0x02	0	64	UDP	0x2982	10.1...	239.2...	1324	0x2ebe
46	0.009243	4	20	0x00	1344	0x0000 (0)	0x02	0	64	UDP	0x2982	10.1...	239.2...	1324	0x49d4
47	0.009492	4	20	0x00	1344	0x0000 (0)	0x02	0	64	UDP	0x2982	10.1...	239.2...	1324	0x7309
48	0.009496	4	20	0x00	1344	0x0000 (0)	0x02	0	64	UDP	0x2982	10.1...	239.2...	1324	0x03b8
49	0.009762	4	20	0x00	1344	0x0000 (0)	0x02	0	64	UDP	0x2982	10.1...	239.2...	1324	0x7c3d
50	0.009947	4	20	0x00	1344	0x0000 (0)	0x02	0	64	UDP	0x2982	10.1...	239.2...	1324	0x5ed1

Figure 5.3 Example capture of input IP stream for adaptation mode 3.

5.4 RDT Transmission

5.4.1 RDT Generation

When the emission side operates in adaptation mode 1 or adaptation mode 2, context_config should be set to '0' or '1', respectively. When the emission side operates in adaptation mode 3, the context_config should be set to '2' or '3' based on the RDT structure as described in Section 7.1.2 of A/330 [1].

5.4.2 RDT Transmission Mode Selection

When the Catalog RDT is used, the Catalog RDT should be transmitted via the PLP in which the LMT is transmitted. This allows the LMT and Catalog RDT to be acquired at the same time.

5.4.3 ROHC Initialization and Refresh

The ROHC standard 0 requires periodic initialization and refresh of the context. This is related to the IR packet generation and RDT repeat rate.

The ROHC standard specifies the periodic refresh of the context initialization. In ATSC 3.0, only the unidirectional mode of ROHC is used, and therefore, periodic initialization should be specified. When a periodic refresh has occurred, the related RDT should be sent immediately. In order to send the RDT at the Real Time Service RAP, the ROHC initialization and refresh period should be the same as the Real Time Service RAP period. If there is no shorter period for initialization and refresh, then 5 seconds should be used as the initialization period. Therefore, ROHC initialization should be aligned with the periodic RDT transmissions.

5.4.4 RDT Retransmission

RDT should be transmitted at a Real Time Service RAP, but it can be retransmitted between the Real Time Service RAPs due to quick acquisition of signaling included in RDT. In this case, if the duration of the PHY frame is shorter than the Real Time Service RAP, it is recommended that the retransmission of RDT should be once per PHY frame. It is also recommended that the retransmitted RDT is located in a position where it can be acquired quickly.

6. RECOMMENDATIONS FOR PACKET ENCAPSULATION

This section provides recommendations for encapsulation and packet format.

6.1 LMT Encapsulation

For efficient transmission of LMT, segmentation and concatenation should not be used for LMT.

6.2 RDT Encapsulation

6.2.1 Encapsulation of Catalog RDT

For the Catalog RDT, concatenation should be used for multiple RDT transmissions at the Real Time Service RAP periods. According to A/330 [1], an RDT can contain context information for only one PLP. When concatenation is used, context information for multiple PLPs can be delivered at the same time. Figure 6.1 shows an example of an ALP packet which contains a Catalog RDT. In this example, it is assumed that there are four PLPs and one RDT is generated for each PLP. The Additional Header for Signaling Information should be common for all RDTs in the payload.

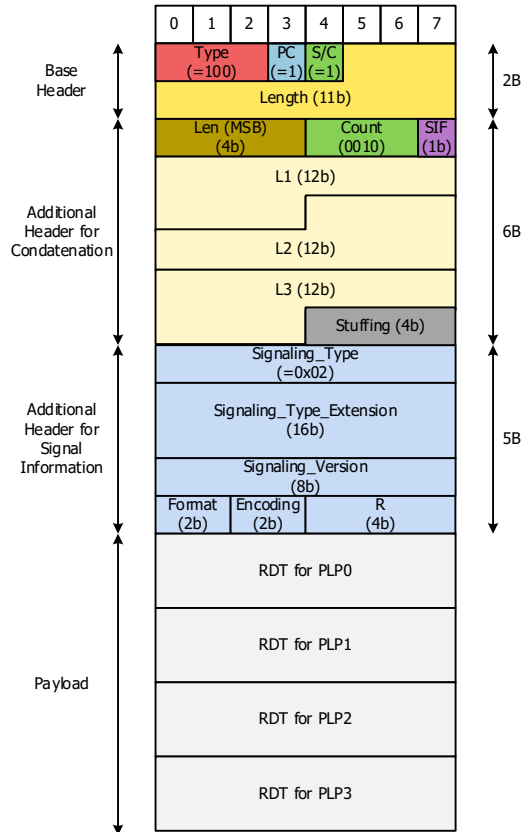

Figure 6.1 Example of ALP signaling packet with Catalog RDT.

7. GUIDELINES FOR IP HEADER DECOMPRESSION

7.1 Synchronization Between RDT and Compressed Packet Flows

Table 7.1 shows the detailed representation of the input stream as shown in Figure 5.3. In this section, there are several examples of IP header decompression assuming that this input stream is compressed and transmitted. From the ROHC operation, sequence numbers are assigned starting with '760' (0x02F8).

Table 7.1 Example of IP/UDP Stream for IP Header Compression

Packet Order	IP header (Hex)	UDP header (Hex)	SN (Dec)	SN (Hex)
1	4500054000004000401129820A7D119EEFFF0011	93713323052C54F0	760	02F8
2	4500054000004000401129820A7D119EEFFF0011	93713323052C925B	761	02F9
3	4500054000004000401129820A7D119EEFFF0011	93713323052C5E8A	762	02FA
4	4500054000004000401129820A7D119EEFFF0011	93713323052C3F4E	763	02FB
5	4500054000004000401129820A7D119EEFFF0011	93713323052C824B	764	02FC
6	4500054000004000401129820A7D119EEFFF0011	93713323052C1AE7	765	02FD
7	4500054000004000401129820A7D119EEFFF0011	93713323052C9483	766	02FE
8	4500054000004000401129820A7D119EEFFF0011	93713323052CF47A	767	02FF
9	4500054000004000401129820A7D119EEFFF0011	93713323052CA533	768	0300
10	4500054000004000401129820A7D119EEFFF0011	93713323052C74DE	769	0301
11	4500054000004000401129820A7D119EEFFF0011	93713323052C357C	770	0302
12	4500054000004000401129820A7D119EEFFF0011	93713323052C8E86	771	0303
13	4500054000004000401129820A7D119EEFFF0011	93713323052C5728	772	0304
14	4500054000004000401129820A7D119EEFFF0011	93713323052C6BC7	773	0305
15	4500054000004000401129820A7D119EEFFF0011	93713323052C9463	774	0306
16	4500054000004000401129820A7D119EEFFF0011	93713323052CA22A	775	0307
17	4500054000004000401129820A7D119EEFFF0011	93713323052CC822	776	0308
18	4500054000004000401129820A7D119EEFFF0011	93713323052C49F4	777	0309
19	4500054000004000401129820A7D119EEFFF0011	93713323052C9892	778	030A
20	4500054000004000401129820A7D119EEFFF0011	93713323052CD18D	779	030B
21	4500054000004000401129820A7D119EEFFF0011	93713323052CE082	780	030C
22	4500054000004000401129820A7D119EEFFF0011	93713323052C41B2	781	030D
23	4500054000004000401129820A7D119EEFFF0011	93713323052CCEFD	782	030E
24	4500054000004000401129820A7D119EEFFF0011	93713323052C3B52	783	030F
25	4500054000004000401129820A7D119EEFFF0011	93713323052C23BB	784	0310
26	4500054000004000401129820A7D119EEFFF0011	93713323052CB631	785	0311
27	4500054000004000401129820A7D119EEFFF0011	93713323052CDD7B	786	0312
28	4500054000004000401129820A7D119EEFFF0011	93713323052C5871	787	0313
29	4500054000004000401129820A7D119EEFFF0011	93713323052CDEEB	788	0314
30	4500054000004000401129820A7D119EEFFF0011	93713323052CB317	789	0315
31	4500054000004000401129820A7D119EEFFF0011	93713323052C91F0	790	0316
32	4500054000004000401129820A7D119EEFFF0011	93713323052CDA39	791	0317
33	4500054000004000401129820A7D119EEFFF0011	93713323052C6032	792	0318
34	4500054000004000401129820A7D119EEFFF0011	93713323052C10E3	793	0319
35	4500054000004000401129820A7D119EEFFF0011	93713323052C42E0	794	031A
36	4500054000004000401129820A7D119EEFFF0011	93713323052CB914	795	031B
37	4500054000004000401129820A7D119EEFFF0011	93713323052CACFA	796	031C
38	4500054000004000401129820A7D119EEFFF0011	93713323052C6CEF	797	031D
39	4500054000004000401129820A7D119EEFFF0011	93713323052C42AD	798	031E
40	4500054000004000401129820A7D119EEFFF0011	93713323052CE8EE	799	031F
41	4500054000004000401129820A7D119EEFFF0011	93713323052C32D6	800	0320
42	4500054000004000401129820A7D119EEFFF0011	93713323052C5C84	801	0321
43	4500054000004000401129820A7D119EEFFF0011	93713323052C670F	802	0322
44	4500054000004000401129820A7D119EEFFF0011	93713323052C48B1	803	0323
45	4500054000004000401129820A7D119EEFFF0011	93713323052C2EBE	804	0324
46	4500054000004000401129820A7D119EEFFF0011	93713323052C49D4	805	0325
47	4500054000004000401129820A7D119EEFFF0011	93713323052C7309	806	0326
48	4500054000004000401129820A7D119EEFFF0011	93713323052C03B8	807	0327
49	4500054000004000401129820A7D119EEFFF0011	93713323052C7C3D	808	0328
50	4500054000004000401129820A7D119EEFFF0011	93713323052C5ED1	809	0329
...

7.1.1 RDT Synchronization in Receiver for Adaptation Mode 2

In this section, recommendations and an example of synchronization between RDT and compressed packets in adaptation mode 2 are provided, including a working example.

Table 7.2 shows the detailed representation of the example compressed stream when adaptation mode 2 is used. In this compressed stream, it is assumed that IR-DYN packets are generated at the first packet and the 30th packet. Additionally, it is assumed that the assigned CID is ‘0’ and compressed packets are of the UO-0 packet type.

Table 7.2 Example of Compressed IP Stream (Adaptation Mode 2)

Packet Order	SN (Hex)	CRC (8-bit)	IR-DYN Header (Hex)	SN_LSB (4-bit)	CRC (3-bit)	UO-0 Header (Hex)
1	02F8	D7	F802D7004000008054F002F8			
2	02F9			9	6	4E
3	02FA			A	5	55
4	02FB			B	2	5A
5	02FC			C	5	65
6	02FD			D	3	6B
7	02FE			E	0	70
8	02FF			F	1	79
9	0300			0	6	06
10	0301			1	7	0F
11	0302			2	1	11
12	0303			3	3	1B
13	0304			4	3	23
14	0305			5	0	28
15	0306			6	5	35
16	0307			7	3	3B
17	0308			8	2	42
18	0309			9	0	48
19	030A			A	0	50
20	030B			B	0	58
21	030C			C	3	63
22	030D			D	1	69
23	030E			E	4	74
24	030F			F	2	7A
25	0310			0	4	04
26	0311			1	6	0E
27	0312			2	3	13
28	0313			3	5	1D
29	0314			4	5	25
30	0315	91	F802910040000080B3170315			
31	0316			6	2	32
32	0317			7	2	3A
33	0318			8	0	40
34	0319			9	3	4B
35	031A			A	1	51
36	031B			B	2	5A
37	031C			C	0	60
38	031D			D	3	6B
39	031E			E	4	74
40	031F			F	5	7D
41	0320			0	0	00
42	0321			1	2	0A
43	0322			2	5	15
44	0323			3	4	1C
45	0324			4	5	25
46	0325			5	3	2B
47	0326			6	7	37
48	0327			7	1	39
49	0328			8	7	47
50	0329			9	2	4A
...

From this packet stream, the RDT can be generated and transmitted in packet 1 and packet 30, and the static chain is shown in Table 7.3.

Table 7.3 Example of Static Chain for RDT

Packet Order	Static chain (Hex)
1	40110A7D119EEFFF001193713323
30	40110A7D119EEFFF001193713323

When the packet stream as shown in Table 7.2 and the RDT including the context information as shown in Table 7.3 are received from separate PLPs, the receiver should perform a synchronization procedure to start the decompression procedure.

In case of adaptation mode 2, it is simple to synchronize between the RDT and a compressed packet stream. First, the receiver has to check the static chain from the received RDT. Next, the receiver has to detect the presence of an IR-DYN packet in the compressed packet stream. In this example, the receiver can detect packet 1 as an IR-DYN packet.

Subsequently, the receiver can recover the original IP header temporarily and perform validation using the CRC. If CRC validation passes, synchronization can be considered successful.

If packet 1 is missed due to reception error, the receiver can attempt to perform decompression as described above using packet 30. The packets which are received prior to packet 30 cannot be decompressed in adaptation mode 2.

7.1.2 RDT Synchronization in Receiver for Adaptation Mode 3

In this section, recommendations and an example of synchronization between RDT and compressed packets in adaptation mode 3 are provided, including a working example.

Table 7.4 shows the detailed representation of the example input stream as shown in Figure 5.3. Additionally, compressed packet headers are listed based on the input stream. In this compressed stream, it is assumed that the assigned CID is '0' and compressed packets are of the UO-0 packet type.

Table 7.4 Example of Compressed IP Stream (Adaptation Mode 3)

PacketOrder	SN (Hex)	SN_LSB (4-bit)	CRC (3-bit)	UO-0 (Hex)
1	02F8	8	0	40
2	02F9	9	6	4E
3	02FA	A	5	55
4	02FB	B	2	5A
5	02FC	C	5	65
6	02FD	D	3	6B
7	02FE	E	0	70
8	02FF	F	1	79
9	0300	0	6	06
10	0301	1	7	0F
11	0302	2	1	11
12	0303	3	3	1B
13	0304	4	3	23
14	0305	5	0	28
15	0306	6	5	35
16	0307	7	3	3B
17	0308	8	2	42
18	0309	9	0	48
19	030A	A	0	50
20	030B	B	0	58
21	030C	C	3	63
22	030D	D	1	69
23	030E	E	4	74
24	030F	F	2	7A
25	0310	0	4	04
26	0311	1	6	0E
27	0312	2	3	13
28	0313	3	5	1D
29	0314	4	5	25
30	0315	5	1	29
31	0316	6	2	32
32	0317	7	2	3A
33	0318	8	0	40
34	0319	9	3	4B
35	031A	A	1	51
36	031B	B	2	5A
37	031C	C	0	60
38	031D	D	3	6B
39	031E	E	4	74
40	031F	F	5	7D
41	0320	0	0	00
42	0321	1	2	0A
43	0322	2	5	15
44	0323	3	4	1C
45	0324	4	5	25
46	0325	5	3	2B
47	0326	6	7	37
48	0327	7	1	39
49	0328	8	7	47
50	0329	9	2	4A
...

From this packet stream, the RDT can be generated using packet 1 and the static chain and dynamic chain are shown in Table 7.5.

Table 7.5 Example of Static Chain and Dynamic Chain for RDT

Packet Order	Static chain (Hex)	Dynamic chain (Hex)
1	40110A7D119EEFFF001193713323	004000008054F002F8

When the packet stream as shown in Table 7.4 and the RDT including the context information as shown in Table 7.5 are received from separate PLPs, the receiver should perform a synchronization procedure to start the decompression procedure.

First, the receiver has to check the sequence number from the dynamic chain, which in this example has the value ‘0x02F8’. Based on this sequence number, the receiver has to verify that the four LSBs of the SN are ‘0x8’. From Table 7.4, these packet numbers are 1, 17, 33, 49 and so on.

Thereafter, the receiver can recover the original IP/UDP header temporarily and attempt to perform validation using the CRC. From this example, the first passing CRC will be packet 1.

Table 7.6 Example of CRC Check of Compressed Header

Packet Order	UO-0 (Hex)	SN_LSB (4-bit)	SN (Hex)	CRC (3-bit)	CRC Result
1	40	8	02F8	0	Pass
17	42	8	0308	2	Fail
33	40	8	0318	0	Fail
49	47	8	0328	7	Fail
...

Based on the result shown in Table 7.6, the receiver can perform packet decompression starting from packet 1.

7.1.3 Decompression Start without RDT Synchronization for Adaptation Mode 3

According to the UDP standard [6], UDP checksum is optional for IPv4. In this case, the UDP checksum field should be set to ‘0x00’ as shown in Table 7.7. When UDP checksum is not used, all the values of fields are the same except for the total length field of IP header, length field of UDP header and SN.

The value of CRC in ROHC packet depends on the total length field of IP header, length field of UDP header and SN. According to ROHC operation, the total length field and UDP length field are never transmitted from compressor to decompressor. Also, SN is assigned in the ROHC compressor. When UDP checksum is not used, RDT can be applied to any compressed packet. In this case, the decompressor can ignore the CRC failure for the fast decompression start, and the decompression procedure can be started at any position of the compressed packet.

Table 7.7 Example of IP Header Compression (Without UDP Checksum)

Packet Order	IP header (Hex)	UDP header (Hex)	SN (Hex)	SN_LSB (4-bit)	CRC (3-bit)	UO-0 (Hex)
1	4500054000004000401129820A7D119EEFFF0011	93713323052C0000	02F8	8	0	40
2	4500054000004000401129820A7D119EEFFF0011	93713323052C0000	02F9	9	6	4E
3	4500054000004000401129820A7D119EEFFF0011	93713323052C0000	02FA	A	5	55
4	4500054000004000401129820A7D119EEFFF0011	93713323052C0000	02FB	B	2	5A
5	4500054000004000401129820A7D119EEFFF0011	93713323052C0000	02FC	C	5	65
6	4500054000004000401129820A7D119EEFFF0011	93713323052C0000	02FD	D	3	6B
7	4500054000004000401129820A7D119EEFFF0011	93713323052C0000	02FE	E	0	70
8	4500054000004000401129820A7D119EEFFF0011	93713323052C0000	02FF	F	1	79
9	4500054000004000401129820A7D119EEFFF0011	93713323052C0000	0300	0	6	06
10	4500054000004000401129820A7D119EEFFF0011	93713323052C0000	0301	1	7	0F
11	4500054000004000401129820A7D119EEFFF0011	93713323052C0000	0302	2	1	11
12	4500054000004000401129820A7D119EEFFF0011	93713323052C0000	0303	3	3	1B
13	4500054000004000401129820A7D119EEFFF0011	93713323052C0000	0304	4	3	23
14	4500054000004000401129820A7D119EEFFF0011	93713323052C0000	0305	5	0	28
15	4500054000004000401129820A7D119EEFFF0011	93713323052C0000	0306	6	5	35
16	4500054000004000401129820A7D119EEFFF0011	93713323052C0000	0307	7	3	3B
17	4500054000004000401129820A7D119EEFFF0011	93713323052C0000	0308	8	2	42
18	4500054000004000401129820A7D119EEFFF0011	93713323052C0000	0309	9	0	48
19	4500054000004000401129820A7D119EEFFF0011	93713323052C0000	030A	A	0	50
20	4500054000004000401129820A7D119EEFFF0011	93713323052C0000	030B	B	0	58
21	4500054000004000401129820A7D119EEFFF0011	93713323052C0000	030C	C	3	63
22	4500054000004000401129820A7D119EEFFF0011	93713323052C0000	030D	D	1	69
23	4500054000004000401129820A7D119EEFFF0011	93713323052C0000	030E	E	4	74
24	4500054000004000401129820A7D119EEFFF0011	93713323052C0000	030F	F	2	7A
25	4500054000004000401129820A7D119EEFFF0011	93713323052C0000	0310	0	4	04
26	4500054000004000401129820A7D119EEFFF0011	93713323052C0000	0311	1	6	0E
27	4500054000004000401129820A7D119EEFFF0011	93713323052C0000	0312	2	3	13
28	4500054000004000401129820A7D119EEFFF0011	93713323052C0000	0313	3	5	1D
29	4500054000004000401129820A7D119EEFFF0011	93713323052C0000	0314	4	5	25
30	4500054000004000401129820A7D119EEFFF0011	93713323052C0000	0315	5	1	29
31	4500054000004000401129820A7D119EEFFF0011	93713323052C0000	0316	6	2	32
32	4500054000004000401129820A7D119EEFFF0011	93713323052C0000	0317	7	2	3A
33	4500054000004000401129820A7D119EEFFF0011	93713323052C0000	0318	8	0	40
34	4500054000004000401129820A7D119EEFFF0011	93713323052C0000	0319	9	3	4B
35	4500054000004000401129820A7D119EEFFF0011	93713323052C0000	031A	A	1	51
36	4500054000004000401129820A7D119EEFFF0011	93713323052C0000	031B	B	2	5A
37	4500054000004000401129820A7D119EEFFF0011	93713323052C0000	031C	C	0	60
38	4500054000004000401129820A7D119EEFFF0011	93713323052C0000	031D	D	3	6B
39	4500054000004000401129820A7D119EEFFF0011	93713323052C0000	031E	E	4	74
40	4500054000004000401129820A7D119EEFFF0011	93713323052C0000	031F	F	5	7D
41	4500054000004000401129820A7D119EEFFF0011	93713323052C0000	0320	0	0	00
42	4500054000004000401129820A7D119EEFFF0011	93713323052C0000	0321	1	2	0A
43	4500054000004000401129820A7D119EEFFF0011	93713323052C0000	0322	2	5	15
44	4500054000004000401129820A7D119EEFFF0011	93713323052C0000	0323	3	4	1C
45	4500054000004000401129820A7D119EEFFF0011	93713323052C0000	0324	4	5	25
46	4500054000004000401129820A7D119EEFFF0011	93713323052C0000	0325	5	3	2B
47	4500054000004000401129820A7D119EEFFF0011	93713323052C0000	0326	6	7	37
48	4500054000004000401129820A7D119EEFFF0011	93713323052C0000	0327	7	1	39
49	4500054000004000401129820A7D119EEFFF0011	93713323052C0000	0328	8	7	47
50	4500054000004000401129820A7D119EEFFF0011	93713323052C0000	0329	9	2	4A
...

From this packet stream, the RDT can be generated using packet 1. The static chain and dynamic chain are shown in Table 7.8.

Table 7.8 Example of Static Chain and Dynamic Chain for RDT

Packet Order	Static Chain (Hex)	Dynamic Chain (Hex)
1	40110A7D119EEFFF001193713323	0040000080000002F8

When the packet stream as shown in Table 7.7 and the RDT including the context information as shown in Table 7.8 are received from separate PLPs, the receiver should perform a synchronization procedure to start the decompression procedure. If the received stream is error-free, the synchronization and decompression operations are the same as in the example described in Section 7.1.2. However, when the compressed packet 1 is missed, this method will not work. Instead of waiting for the next RDT, the receiver can attempt to perform unsynchronized decompression.

First, the receiver has to check the sequence number from the dynamic chain, which in this example has the value ‘0x02F8’. Based on this sequence number, the receiver has to verify that the four LSBs of the SN are ‘0x8’. Assuming that packet 1 is missed, there will be no packet for which the CRC can pass. In this case, instead of packet 1, the receiver can attempt to recover the packet header using packet 2 and RDT. Additionally, because the four LSBs of SN are ‘0x9’ in packet 2, the full length of SN can be converted as ‘0x02F9’.

Subsequently, the receiver can recover the original IP/UDP header temporarily and attempt to perform validation using the CRC. From this example, the first passing CRC will be packet 2.

7.2 Guidelines for ROHC Decoding

7.2.1 Determination of IP-ID Behavior

There are only two cases of IP-ID behavior according to the restrictions in emission side, as specified in A/330 [1] and A/331 [3]; unused IP-ID and sequential IP-ID cases. In a receiver, in order to determine the IP-ID behavior, dynamic chain should be obtained. For adaptation mode 1, dynamic chain can be obtained from IR/IR-DYN packets. For adaptation mode 2, dynamic chain can be obtained from IR-DYN packet. For adaptation mode 3, dynamic chain can be obtained from RDT signaling.

When the DF field in the obtained dynamic chain is ‘1’, it can be considered that IP-ID is not used. Therefore, IP-ID decoding should be skipped and the IP-ID field in recovered IP packets should be set to default value (‘0x00’). When the DF field in the obtained dynamic chain is ‘0’, it can be considered that sequential IP-ID is used. Therefore, offset IP-ID decoding should be performed to recover the original IP-ID.

Annex A: Interoperability Functional Tests

A.1 TEST CASES

Table A.1.1 provides essential test cases for interoperability functional tests between emission side and receiver.

[Note: The contents of this table may be updated based on the discussion about interoperability tests.]

Table A.1.1 List of Interoperability Functional Tests

Test No.	Test configurations		IP Header Compression				Encapsulation					Check Point	Required Test	
	PLP	ALP input	ROHC	IP-ID encoding	Adapt. Mode	RDT	Payload	SID Mode	ALP Header					
1	Single PLP	IP Stream, Packet length ≤ 2047	off	N/A	N/A	N/A	IP	off	BH				Packet transmission/reception, Base Header	
2	Single PLP	IP Stream, Packet length > 2047	off	N/A	N/A	N/A	IP	off	BH	AH_Single			Additional Header for Single Packet	1
3	Single PLP	IP Stream	off	N/A	N/A	N/A	IP	off	BH	AH_Seg.			Additional Header for Segmentation	1
4	Single PLP	IP Stream	off	N/A	N/A	N/A	IP	off	BH	AH_Conc.			Additional Header for Concatenation	1
5	Single PLP	IP Stream	off	N/A	N/A	N/A	LMT	off	BH		AH_Sig. (LMT)		Additional Header for Signaling, LMT	1
6	Multiple PLPs	Multiple IP streams	off	N/A	N/A	N/A	LMT	off	BH		AH_Sig. (LMT)		PLP selection with LMT (PLP - addr. & port)	1, 5
							IP							
7	Single PLP	Multiple IP streams	off	N/A	N/A	N/A	LMT	on	BH	AH_Single	AH_Sig. (LMT)	EH_SID	Extension header for SID, IP stream selection with LMT (SID - addr. & port)	2, 3, 4, 5
							IP							
							AH_Seg.							
8	Multiple PLPs	Multiple IP streams	off	N/A	N/A	N/A	LMT	on	BH	AH_Single	AH_Sig. (LMT)	EH_SID	PLP and IP stream selection with LMT (PLP - SID - addr. & port)	6, 7
							IP							
							AH_Seg.							
9	Single PLP	Single IP stream with IP-ID = 0x00	on	No Encoding	Mode 1	Discrete RDT	LMT	off	BH		AH_Sig. (LMT)		Simple ROHC operation, Discrete RDT	1, 5
							RDT							
							Comp. IP							
10	Single PLP	Single IP stream with IP-ID = 0x00	on	No Encoding	Mode 2	Discrete RDT	LMT	off	BH		AH_Sig. (LMT)	EH_SID	Adaptation Mode 2 with Discrete RDT	9
							RDT							
							Comp. IP							
11	Single PLP	Single IP stream with IP-ID = 0x00	on	No Encoding	Mode 3	Discrete RDT	LMT	off	BH		AH_Sig. (LMT)	EH_SID	Adaptation Mode 3 with Discrete RDT	10
							RDT							
							Comp. IP							
12	Single PLP	Single IP stream	on	Offset IP-ID Encoding	Mode 1	Discrete RDT	LMT	off	BH		AH_Sig. (LMT)			9

		with Sequential IP-ID					RDT				AH_Sig. (RDT)		Offset IP-ID encoding, Adaptation Mode 1 with Discrete RDT	
							Comp. IP							
13	Single PLP	Single IP stream with Sequential IP-ID	on	Offset IP-ID Encoding	Mode 2	Discrete RDT	LMT	off	BH		AH_Sig. (LMT)		Offset IP-ID encoding, Adaptation Mode 2 with Discrete RDT	10, 12
							RDT				AH_Sig. (RDT)			
							Comp. IP							
14	Single PLP	Single IP stream with Sequential IP-ID	on	Offset IP-ID Encoding	Mode 3	Discrete RDT	LMT	off	BH		AH_Sig. (LMT)		Offset IP-ID encoding, Adaptation Mode 3 with Discrete RDT	11, 13
							RDT				AH_Sig. (RDT)			
							Comp. IP							
15	Multiple PLPs	Multiple IP streams with IP-ID = 0x00	on	No Encoding	Mode 1	Catalog RDT	LMT	off	BH	AH_Conc.	AH_Sig. (LMT)		Catalog RDT via separate PLP	4, 6, 9
							RDT				AH_Sig. (RDT)			
							Comp. IP							
16	Multiple PLPs	Multiple IP streams with IP-ID = 0x00	on	No Encoding	Mode 2	Catalog RDT	LMT	off	BH	AH_Conc.	AH_Sig. (LMT)		Catalog RDT via separate PLP, Synchronization in Adaptation Mode 2	10, 15
							RDT				AH_Sig. (RDT)			
							Comp. IP							
17	Multiple PLPs	Multiple IP streams with IP-ID = 0x00	on	No Encoding	Mode 3	Catalog RDT	LMT	off	BH	AH_Conc.	AH_Sig. (LMT)		Catalog RDT via separate PLP, Synchronization in Adaptation Mode 3	11, 16
							RDT				AH_Sig. (RDT)			
							Comp. IP							
18	Multiple PLPs	Multiple IP streams with Sequential IP-ID	on	Offset IP-ID Encoding	Mode 1	Catalog RDT	LMT	off	BH	AH_Conc.	AH_Sig. (LMT)		Catalog RDT via separate PLP, Offset IP-ID encoding	12, 15
							RDT				AH_Sig. (RDT)			
							Comp. IP							
19	Multiple PLPs	Multiple IP streams with Sequential IP-ID	on	Offset IP-ID Encoding	Mode 2	Catalog RDT	LMT	off	BH	AH_Conc.	AH_Sig. (LMT)		Catalog RDT via separate PLP, Synchronization in Adaptation Mode 2, Offset IP-ID encoding	13, 16, 18
							RDT				AH_Sig. (RDT)			
							Comp. IP							
20	Multiple PLPs	Multiple IP streams with Sequential IP-ID	on	Offset IP-ID Encoding	Mode 3	Catalog RDT	LMT	off	BH	AH_Conc.	AH_Sig. (LMT)		Catalog RDT via separate PLP, Synchronization in Adaptation Mode 3, Offset IP-ID encoding	14, 17, 18
							RDT				AH_Sig. (RDT)			
							Comp. IP							

— End of Document —