



The Broadcast[®]
Standards
Association



ATSC Recommended Practice: Conversion of ATSC 3.0 Services for Redistribution

A/370:2026-04

14 April 2026

ATSC[®], the Broadcast Standards Association[®], is an international, non-profit organization developing voluntary standards and recommended practices for broadcast television and multimedia data distribution. ATSC member organizations represent the broadcast, professional equipment, motion picture, consumer electronics, computer, cable, satellite, and semiconductor industries. ATSC also develops implementation strategies and supports educational activities on ATSC standards. ATSC was formed in 1983 by the member organizations of the Joint Committee on Inter-society Coordination (JCIC): the Consumer Technology Association (CTA), the Institute of Electrical and Electronics Engineers (IEEE), the National Association of Broadcasters (NAB), the Internet & Television Association (NCTA), and the Society of Motion Picture and Television Engineers (SMPTE). For more information visit www.atsc.org.

© Copyright 2026 ATSC. All rights reserved.

Note: The user's attention is called to the possibility that compliance with this standard may require use of an invention covered by patent rights. By publication of this standard, no position is taken with respect to the validity of this claim or of any patent rights in connection therewith. One or more patent holders have, however, filed a statement regarding the terms on which such patent holder(s) may be willing to grant a license under these rights to individuals or entities desiring to obtain such a license. Details may be obtained from the ATSC Secretary and the patent holder.

Implementers with feedback, comments, or potential bug reports relating to this document may contact ATSC at <https://www.atsc.org/feedback/>.

Revision History

Version	Date
A/370:2019 approved	11 December 2019
A/370:2022-03 (references to ATSC documents updated)	31 March 2022
A/370:2023-03 (references to ATSC documents updated)	28 March 2023
A/370:2024-04 (references to ATSC documents updated)	3 April 2024
A/370:2025-07 (references to ATSC documents updated)	17 July 2025
A/370:2026-04 (references to ATSC documents updated)	14 April 2026

Table of Contents

1.	SCOPE	1
	1.1 Introduction and Background	1
	1.2 Use Cases and Scope of Recommendations	1
	1.3 Organization	3
2.	REFERENCES	3
	2.1 Informative References	3
3.	DEFINITION OF TERMS	7
	3.1 Compliance Notation	7
	3.2 Treatment of Syntactic Elements	7
	3.2.1 Reserved Elements	8
	3.3 Acronyms and Abbreviations	8
	3.4 Terms	11
4.	SYSTEM OVERVIEW	12
	4.1 Conceptual Integrated Receiver Decoder Transcoder Packager (IRDTP)	13
	4.2 IRDTP Conceptual Diagram	15
	4.3 IRDTP BLOCK Descriptions	16
	4.4 IRDTP MODULE Descriptions	16
	4.5 IRDTP INTERFACE Descriptions	17
5.	NON-CONVERTED ATSC 3.0 FEATURES	18
6.	RECEPTION AND SERVICE IDENTIFICATION	19
	6.1 Physical Layer	19
	6.1.1 A/321: System Discovery and Signaling	19
	6.1.2 A/322: Physical Layer Protocol	19
	6.1.3 A/323: Dedicated Return Channel for ATSC 3.0	19
	6.1.4 A/324: Scheduler/Studio to Transmitter Link	20
	6.2 Management and Protocols Layer	20
	6.2.1 A/330: Link-Layer Protocol	20
	6.2.2 A/331: Signaling, Delivery, Synchronization, and Error Protection	20
	6.2.3 A/332: Service Announcement	20
	6.2.4 A/333: Service Usage Reporting	22
	6.2.5 A/337: Application Signaling	22
7.	APPLICATIONS AND PRESENTATION LAYER	22
	7.1 Video Processing	22
	7.1.1 3D Video	24
	7.2 Audio Processing	26
	7.2.1 ATSC 3.0 Audio Standards	26
	7.2.2 Background	26
	7.2.3 Manual Audio Transcoding with AC-4 and MPEG-H	28
	7.2.4 Action Required for Manual Conversion of ATSC 3.0 AC-4 and MPEG-H Audio to ATSC 1.0 AC-3 Audio	29
	7.3 Closed Captions and Subtitles Processing	32
	7.3.1 A/343: Captions and Subtitles	32

8. EMERGENCY ALERTING	32
8.1 Audio and Video	33
9. SECURITY	33
9.1 A/360: ATSC 3.0 Security and Service Protection	33
9.2 A/360: ATSC 3.0 Security and Service Protection (Cryptographic Signing)	33
10. ATSC 3.0 AUDIO AND VIDEO WATERMARKS	33
10.1 A/335: Video Watermark Emission	33
10.2 A/334: Audio Watermark Emission	34
10.3 A/336: Content Recovery in Redistribution Scenarios	34
11. INTERACTIVE CONTENT	34
12. REGIONAL SERVICE AVAILABILITY SIGNALING	35
ANNEX A : VIDEO FORMAT CONVERSION CONSIDERATIONS	36
A.1 Video Format Conversions	36
A.2 Practical Implementation and User Considerations	41
A.3 Conversion From a Single Spatial Layer Encoded ATSC 3.0 Signal	41
A.3.1 Spatial Resolution(s)	43
A.3.2 Interlaced to Progressive Scan Conversion (De-interlacing)	43
A.3.3 Frame Rate Conversion	44
A.3.4 Transfer Characteristic and Color Gamut Conversions	45
A.3.5 Color Components	46
A.3.6 Signal Range (Full-Range to Narrow-Range)	46
A.3.7 Progressive to Interlaced Scan Conversion	46
A.3.8 Sample Bit Depth	47
A.3.9 Aspect Ratio	47
A.4 Conversion from a Two-Layer Spatially Scalable Encoded ATSC 3.0 Signal	48
A.5 Conversion from an SL-HDR1 Encoded ATSC 3.0 Signal	49
A.6 Informational References on De-Interlacing and Scan Conversion	49
A.7 Informational References on Frame Rate Conversion	50

Index of Tables and Figures

Table 1.1 Use Cases and Required Conversions	2
Table 6.1 Recommendations for the Signaling of Service Elements in the Translation from ATSC 3.0 to ATSC 1.0	21
Table A.1 Conversions of Some Anticipated ATSC 3.0 Video Formats to Associated ATSC 1.0 Video Formats	39
Table A.2 Conversions of Anticipated ATSC 3.0 Video Formats to Associated ATSC 1.0 Video Formats	40
Figure 4.1 Block diagram of ATSC 3.0 conversion for Redistribution.	12
Figure 4.2 Conceptual signal flow for conversion of video, audio, and captions Essence.	13
Figure 4.3 IRDTP operation.	14
Figure 4.4 IRDTP process flow.	15
Figure 7.1 Example of ATSC 3.0 to ATSC 1.0 3D video format conversion - 3D service mode using HEVC.	25
Figure 7.2 Example of ATSC 3.0 to ATSC 1.0 3D video format conversion - 3D service mode using SHVC.	26
Figure 7.3 ATSC 3.0 to ATSC 1.0 audio conversion – manual transcoding with AC-4.	28
Figure 7.4 ATSC 3.0 to ATSC 1.0 audio conversion – manual transcoding with MPEG-H.	28
Figure 8.1 Content delivery of the EAS audio.	33
Figure A.1 Example video format conversion flow with spatial conversion followed by frame rate conversion and color conversion.	42
Figure A.2 Example video format conversion flow with color and frame rate conversion followed by spatial resolution conversion.	42
Figure A.3 Example flow for conversion of ATSC 3.0 streams to ATSC 1.0 streams.	49

ATSC Recommended Practice: Conversion of ATSC 3.0 Services for Redistribution

1. SCOPE

1.1 Introduction and Background

ATSC 3.0 is a suite of voluntary technical Standards and Recommended Practices for a digital terrestrial television broadcast system. ATSC 3.0 is fundamentally different from predecessor ATSC systems¹ and is therefore largely incompatible with them. Because of these differences and incompatibilities, an ATSC 3.0 service will not be recognizable to legacy receivers or systems that are specific to ATSC 1.0. Consumers of ATSC 3.0 services are required to utilize new systems and processing for reception of the new signals. In general, this means that new receivers are necessary to handle ATSC 3.0 broadcast and broadband signals and services. Distribution of ATSC 3.0 services to ATSC 1.0 or other legacy distribution formats ingest systems must include a conversion for those features and services that are supported by the legacy distribution systems.

In many situations, the conversion of ATSC 3.0 services may not be necessary, especially for example while ATSC 1.0 and ATSC 3.0 services are Simulcast by broadcasters. In particular:

- ATSC 1.0 over-the-air signals may continue to be utilized.
- Direct feeds from stations to Multichannel Video Programming Distributors (MVPDs) may provide a high-quality ATSC 1.0 signal that is encoded directly from the source programming's baseband Essence streams (i.e., video, audio, closed captioning). A TV station may provide a higher-quality ATSC 1.0 signal via direct feed than may be available as an over-the-air signal. A TV station may provide an ATSC 1.0 signal via direct feed even when its ATSC 1.0 over-the-air service has been discontinued.

Such situations are often subject to commercial agreements, which are beyond the scope of this document.

1.2 Use Cases and Scope of Recommendations

This document provides recommended practices for the conversion of ATSC 3.0 services for Redistribution into ATSC 1.0 and other legacy services. Hardware or software products can be built to implement conversions of ATSC 3.0 services and signals to formats suitable for various Redistribution systems, or over-the-air broadcast Translators. Such conversions might require certain methods for physical layer transmission, transport, audio, video, closed captioning and ancillary data formats. The interface between an ATSC 3.0 station and conversion devices will involve either over-the-air ATSC 3.0 reception, or a direct connection (e.g., IP delivery over fiber). Conversion devices will provide ATSC 1.0 broadcast television delivered via MPEG Transport Streams, with video coded as MPEG-2 [3] or AVC [4], audio coded as AC-3 [5], and closed captions coded as CTA-608/708 [6]. Since conversions must be performed in any ATSC 3.0 Redistribution scenario, audio conversion characteristics and recommendations are included in Section 7.2 Audio Processing, and video conversion characteristics and recommendations are

¹ These systems include the original ATSC DTV system (retrospectively and informally referred to as "ATSC 1.0"), which is defined in ATSC A/53 [1] and other standards, and its backward-compatible updates referred to as "ATSC 2.0", as defined in ATSC A/107 [2] and other standards.

included in both Section 7.1 Video Processing and Annex A: Video Format Conversion Considerations, with this latter section also including additional industry references to existing recommendations for conversions.

There are a number of use cases that may involve conversion of ATSC 3.0 services for Redistribution, including (but not limited to):

- **Use Case 1:** Conversion of ATSC 3.0 signals to ATSC 1.0 for MVPDs and other service providers ingest and delivery, currently operating with ATSC 1.0 inputs to their distribution systems.
 - Use Case 1-1: Conversion is performed at the broadcast station and sent via direct feed to MVPD as an ATSC 1.0 MPEG-2/TS signal.
 - In most cases, it is anticipated that baseband Essence signals (video, audio and closed captioning) are available at the broadcast station. Conversions can be performed as needed prior to encoding for Redistribution.
 - If only HEVC/IP signals are available at the broadcast station, the conversion recommendations of Use Case 1-2 apply.
 - Use Case 1-2: Conversion performed at the MVPD of a direct feed HEVC/IP signal (not at RF) will require signal decoding, Essence (video, audio format and closed caption) conversion, and creation of an ATSC 1.0 transport stream or RF signal.
 - Use Case 1-3: Conversion performed at the MVPD using an ATSC 3.0 over-the-air signal (full conversion will be required)
- **Use Case 2:** Conversion of ATSC 3.0 over-the-air signal to ATSC 1.0 for a TV Translator System that will deliver an ATSC 1.0 over-the-air signal in distant areas. In many cases a signal is often RF in / RF out, but other input connections are possible. For emission of ATSC 1.0 signals derived from ATSC 3.0, a conversion process is necessary. In this use case, the conversion occurs at the Translator system.
- **Use Case 3:** Conversion of ATSC 3.0 over-the-air signals to ATSC 1.0 signals for distributing the signal within a building equipped with a Master Antenna TV (MATV) system, such as an apartment complex. Note that this Use Case 3 has similar processing as Use Case 2.

These Use Cases are summarized in Table 1.1. The rightmost column of Table 1.1 labeled “Convert at:” shows the possible or preferred location for where conversion is performed. For example, in Use Cases 1-1 and 2 (Stations and Translators), the broadcaster facilities are the locations for the conversions, whereas in Use Cases 1-2 and 1-3 (ATSC 3.0 direct feed or OTA pickup), the conversion is presented as performed at MVPD facilities, and in Use Case 3 (MATV Systems), the conversion is presented as performed using third party facilities in an unmonitored operation.

Table 1.1 Use Cases and Required Conversions

Use Case	Video	Audio	CC	Compression	Transport	RF	Convert at:
1-1: Baseband Essence conversion with direct feed or RF ATSC 1.0 to MVPD*	x	x	x			x	Station
1-2: Direct feed ATSC 3.0 to MVPD	x	x	x	x	x	x**	MVPD
1-3: ATSC 3.0 OTA to MVPD	x	x	x	x	x	x	MVPD
2 ATSC 3.0 to 1.0 Translator	x	x	x	x	x	x	Translator
3 MATV systems	x	x	x	x	x	x	MATV

Use Case	Video	Audio	CC	Compression	Transport	RF	Convert at:
*Only the Essence (e.g. Video, Audio and CC) conversions, as needed							

**Note: While transport and RF may be indicated in the table, one or both might be implemented by the MVPD as necessary.

1.3 Organization

This document is organized as follows:

- Section 1 – Outlines the scope of this document and provides a general introduction.
- Section 2 – Lists references and applicable documents.
- Section 3 – Definitions of terms, acronyms, and abbreviations for this document.
- Section 4 – Provides the System Overview, and a description of a Conceptual Integrated Receiver Decoder Transcoder Packager to facilitate an understanding of the different components involved in an ATSC 3.0 conversion to ATSC 1.0.
- Section 5 – Provides an overview of the features in ATSC 3.0 that are not recommended to be involved in a conversion to ATSC 1.0.
- Section 6 – Includes recommendations and details on the physical and signaling features for translating an ATSC 3.0 service for delivery to ATSC 1.0.
- Section 7 – Applications and Presentation Layer includes recommendations and details on audio and video signal Essence translations, including closed captions and subtitles.
- Section 8 – Describes recommended translations needed for Emergency Alerting support.
- Section 9 – Provides a brief description of ATSC 3.0 Security in relation to ATSC 1.0.
- Section 10 – Describes ATSC 3.0 watermarking with ATSC 1.0.
- Section 11 – Provides a brief description of how ATSC 3.0 Interactive Content can be handled in ATSC 1.0.
- Section 12 – Recommendation for using the ATSC 3.0 Regional Service Availability Signaling capability.
- Annex A – Video Format Conversion Considerations details various methods and procedures that are involved in converting ATSC 3.0 video and audio services for Redistribution into ATSC 1.0, and other legacy signals and services.

2. REFERENCES

All referenced documents are subject to revision. Users of this Recommended Practice are cautioned that newer editions might or might not be compatible.

2.1 Informative References

The following documents contain information that may be helpful in applying and implementing these Recommended Practices.

- [1] ATSC: “ATSC Digital Television Standard, Parts 1 through 6 – Digital Television System,” Doc. A/53, ATSC, Washington, DC, various dates.
- [2] ATSC: “ATSC Standard: A/107 – ATSC 2.0 Standard,” Doc. A/107:2015, ATSC, Washington, DC, 15 June 2015.
- [3] ATSC: “ATSC Digital Television Standard, Part 4 – MPEG-2 Video System Characteristics,” Doc. A/53, Part 4:2009, ATSC, Washington, DC, 7 August 2009.

- [4] ITU | ISO/IEC: “Rec. ITU-T H.264 (04/2017) | ISO/IEC 14496-10 Series H: Audiovisual and Multimedia Systems. Infrastructure of audiovisual services – Coding of moving video, Advanced video coding for generic audiovisual services,” Rec. ITU-T H.264, International Telecommunication Union, Geneva, Switzerland.
- [5] ATSC: “ATSC Standard: Digital Audio Compression (AC-3) (E-AC-3) Standard,” Doc. A/52:2018, ATSC, Washington, DC, 25 January 2018.
- [6] CEA: “Digital Television (DTV) Closed Captioning,” Doc. CEA-708-D, Consumer Electronics Association, Arlington, VA, August 2008.
- [7] IEEE: “Use of the International Systems of Units (SI): The Modern Metric System,” Doc. SI 10-2002, Institute of Electrical and Electronics Engineers, New York, NY.
- [8] ATSC: “ATSC Standard: ATSC 3.0 System,” Doc. A/300:2026-04, ATSC, Washington, DC, 14 April 2026.
- [9] ISO/IEC 23008-1, MPEG-H Part 1, MPEG media transport (MMT), International Organization for Standardization/International Electrotechnical Commission, Geneva, Switzerland.
- [10] ITU | ISO/IEC: “Rec. ITU-T H.265 (02/2018) | ISO/IEC 23008-2, MPEG-H Part 2, Series H: Audiovisual and Multimedia Systems. Infrastructure of audiovisual services – Coding of moving video, High efficiency video coding,” International Organization for Standardization/International Electrotechnical Commission, Geneva, Switzerland.
- [11] W3C: “TTML Profiles for Internet Media Subtitles and Captions 1.0.1 (IMSC1),” W3C Recommendation, Worldwide Web Consortium, 24 April 2018. <https://www.w3.org/TR/ttml-imscl/>
- [12] W3C: “HTML5.2,” W3C Recommendation, Worldwide Web Consortium, 14 December 2017. <https://www.w3.org/TR/html/>
- [13] ATSC: “ATSC Standard: System Discovery and Signaling,” Doc. A/321:2026-04, ATSC, Washington, DC, 14 April 2026.
- [14] ATSC: “ATSC Standard: Physical Layer Protocol,” Doc. A/322:2026-04, ATSC, Washington, DC, 14 April 2026.
- [15] ATSC: “ATSC Standard: Dedicated Return Channel for ATSC 3.0,” Doc. A/323:2026-04, ATSC, Washington, DC, 14 April 2026.
- [16] ATSC: “ATSC Standard: Scheduler / Studio to Transmitter Link,” Doc. A/324:2026-04, ATSC, Washington, DC, 14 April 2026.
- [17] ATSC: “ATSC Standard for Transmitter Synchronization,” Doc. A/110:2011, ATSC, Washington, DC, 8 April 2011.
- [18] ATSC: “ATSC Standard: Link Layer Protocol,” Doc. A/330:2026-04, ATSC, Washington, DC, 14 April 2026.
- [19] ATSC: “ATSC Standard: Signaling, Delivery, Synchronization, and Error Protection,” Doc. A/331:2026-04, ATSC, Washington, DC, 14 April 2026.
- [20] ATSC: “Program and System Information Protocol for Terrestrial Broadcast and Cable,” Doc. A/65:2013, ATSC, Washington, DC, 7 August 2013.
- [21] ATSC: “ATSC Standard: Service Announcement,” Doc. A/332:2026-04, ATSC, Washington, DC, 14 April 2026.

- [22] SMPTE: “Standard for Television — Bit-Serial Digital Interface for High-Definition Television Systems,” Doc. SMPTE 292M-1998, Society of Motion Picture and Television Engineers, White Plains, NY, 1998.
- [23] ATSC: “ATSC Standard: A/342 Part 2, AC-4 System,” Doc. A/342-2:2026-04, ATSC, Washington, DC, 14 April 2026.
- [24] SMPTE: “SMPTE Standard - Dynamic Metadata for Color Volume Transform — Core Components,” Doc. SMPTE.ST 2094-1:2016, Society of Motion Picture and Television Engineers, White Plains, NY, 13 June 2016.
- [25] SMPTE: “SMPTE Standard - High Dynamic Range Electro-Optical Transfer Function of Mastering Reference Displays,” Doc. SMPTE.ST 2084:2014, Society of Motion Picture and Television Engineers, White Plains, NY, 29 August 2014.
- [26] ITU: “Recommendation ITU-R BT.2020-2 – Parameter values for ultra-high definition television systems for production and international programme exchange,” Rec. ITU-R BT.2020-2 (10/2015), International Telecommunication Union, Geneva, Switzerland. <https://www.itu.int/rec/R-REC-BT.2020>
- [27] ITU: “Recommendation ITU-R BT.2100-2 – Image parameter values for high dynamic range television for use in production and international programme exchange,” Rec. ITU-R BT.2100-2 (07/2018), International Telecommunication Union, Geneva, Switzerland. <https://www.itu.int/rec/R-REC-BT.2100>
- [28] ITU: “Recommendation ITU-R BT.709-6 – Parameter values for the HDTV standards for production and international programme exchange,” Rec. ITU-R BT.709-6 (06/2015), International Telecommunication Union, Geneva, Switzerland. <https://www.itu.int/rec/R-REC-BT.709>
- [29] ITU: “Recommendation ITU-R BT.1886-0 – Reference electro-optical transfer function for flat panel displays used in HDTV studio production,” Rec. ITU-R BT.1886-0 (03/2011), International Telecommunication Union, Geneva, Switzerland. <https://www.itu.int/rec/R-REC-BT.1886>
- [30] ATSC: “ATSC Standard: Video – HEVC,” Doc. A/341:2026-04, ATSC, Washington, DC, 14 April 2026.
- [31] SMPTE: “SMPTE Standard – Format for Active Format Description and Bar Data,” Doc. SMPTE.ST 2016-1:2009, Society of Motion Picture and Television Engineers, White Plains, NY, 23 December 2009.
- [32] ATSC: “ATSC Standard: Service Usage Reporting,” Doc. A/333:2026-04, ATSC, Washington, DC, 14 April 2026.
- [33] ATSC: “ATSC Standard: A/105 – Interactive Services Standard,” Doc. A/105:2015, ATSC, Washington, DC, 29 October 2015.
- [34] ATSC: “ATSC Standard: Application Signaling,” Doc. A/337:2026-04, ATSC, Washington, DC, 14 April 2026.
- [35] ATSC: “ATSC Standard: Video System Characteristics of AVC in the ATSC Digital Television System,” Doc. A/72 Part 1:2023:04, ATSC, Washington, DC, 25 April 2023.
- [36] ATSC: “3D-TV Terrestrial Broadcasting, Part 2 – Service Compatible Hybrid Coding Using Real-Time Delivery,” Doc. A/104 Part 2: 2012, ATSC, Washington, DC, December 26, 2012.

- [37] ATSC: “3D-TV Terrestrial Broadcasting, Part 5 – Service Compatible 3D-TV Using Main and Mobile Hybrid Delivery,” Doc. A/104 Part 5: 2015, ATSC, Washington, DC, October 28, 2015.
- [38] ATSC: “ATSC Standard: A/342 Part 1, Audio Common Elements,” Doc. A/342-1:2026-04, ATSC, Washington, DC, 14 April 2026.
- [39] ATSC: “ATSC Standard: A/342 Part 3, MPEG-H System,” Doc. A/342-3:2026-04, ATSC, Washington, DC, 14 April 2026.
- [40] ATSC: “ATSC Standard: Content Recovery in Redistribution Scenarios,” Doc. A/336:2026-04, ATSC, Washington, DC, 14 April 2026.
- [41] ATSC: “ATSC Recommended Practice: Techniques for Establishing and Maintaining Audio Loudness for Digital Television,” Doc. A/85:2013, ATSC, Washington, DC, 12 March 2013. See also A/85:2013 Corrigendum No. 1, “SPL,” approved 11 February 2021.
- [42] ATSC: “ATSC Standard: Captions and Subtitles,” Doc. A/343:2026-04, ATSC, Washington, DC, 14 April 2026.
- [43] SMPTE: “SMPTE Standard – Timed Text Format (SMPTE-TT),” Doc. SMPTE.ST 2052-1:2013, Society of Motion Picture and Television Engineers, White Plains, NY, 13 June 2013.
- [44] SMPTE: “SMPTE Recommended Practice – Conversion from CEA-708 Caption Data to SMPTE-TT,” Doc. SMPTE.RP 2052-11:2013, Society of Motion Picture and Television Engineers, White Plains, NY, 5 June 2013.
- [45] ATSC: “ATSC Standard: ATSC 3.0 Security and Service Protection,” Doc. A/360:2026-04, ATSC, Washington, DC, 14 April 2026.
- [46] ATSC: “ATSC Standard: Conditional Access System for Terrestrial Broadcast (A/70 Part 1:2010),” Doc. A/70 Part 1:2010, ATSC, Washington, DC, 30 November 2010.
- [47] ATSC: “ATSC Standard: A/70 Part 2: Conditional Access System for Terrestrial Broadcast Service Protection Using Simulcrypt For IP-Delivered Services,” Doc. A/70 Part 2:2011, ATSC, Washington, DC, 17 October 2011.
- [48] ATSC: “ATSC Standard: Audio Watermark Emission,” Doc. A/334:2026-04, ATSC, Washington, DC, 14 April 2026.
- [49] ATSC: “ATSC Standard: Video Watermark Emission,” Doc. A/335:2026-04, ATSC, Washington, DC, 14 April 2026.
- [50] ATSC: “ATSC Recommended Practice: Audio Watermark Modification and Erasure,” Doc. A/339:2026-04, ATSC, Washington, DC, 14 April 2026.
- [51] ITU: “Report ITU-R BT.2408-2 – Operational practices in HDR television production,” Rep. ITU-R BT.2408-2 (04/2019), International Telecommunication Union, Geneva, Switzerland. <https://www.itu.int/pub/R-REP-BT.2408>
- [52] ITU: “Report ITU-R BT.2390-6 – High dynamic range television for production and international programme exchange,” Rep. ITU-R BT.2390-6 (04/2019), International Telecommunication Union, Geneva, Switzerland. <https://www.itu.int/pub/R-REP-BT.2390>
- [53] ITU: “Recommendation ITU-R BT.2035 – A reference viewing environment for evaluation of HDTV program material or completed programmes,” Rep. ITU-R BT.2035 (07/2013), International Telecommunication Union, Geneva, Switzerland. <https://www.itu.int/rec/R-REC-BT.2035/en>

- [54] ATSC: “ATSC Standard: Regional Service Availability,” Doc. A/200:2026-04, ATSC, Washington, DC, 14 April 2026.
- [55] CTA: “CTA CEB16-A Active Format Description (AFD) & Bar Data Recommended Practice (Formerly CEA-CEB16-A),” Doc. CTA-CEB16-A (2012), Consumer Electronics Association, Arlington, VA, 2012.
- [56] SMPTE: “SMPTE Standard – Ultra High Definition Television – Image Parameter Values for Program Production,” Doc. SMPTE.ST 2036-1:2014, Society of Motion Picture and Television Engineers, White Plains, NY, 30 October 2014.
- [57] SCTE: “AVC Video Constraints for Cable Television Part 1: Coding,” Doc. ANSI/SCTE 128-1 2018, Society of Cable Telecommunications Engineers, Exton, PA, 2018.
- [58] SCTE: “HEVC Video Constraints for Cable Television Part 1: Coding,” Doc. ANSI/SCTE 215-1 2018, Society of Cable Telecommunications Engineers, Exton, PA, 2018.
- [59] CFR: TITLE 47 Chapter 1, Subpart A, PART 11 Emergency Alert System (EAS), United States Government Code of Federal Regulations, Washington DC, 1 October 2010.
- [60] ETSI: “Digital Audio Compression (AC-4) Standard; Part 2: Immersive and personalized audio,” Doc. TS 103 190-2 V1.1.1 (2015-08-30), ETSI, Sophia Antipolis Cedex, France.
- [61] ETSI: “High Performance Single Layer Directly Standard Dynamic Range (SDR) Compatible High Dynamic Range (HDR) System for use in Consumer Electronics Devices (SL-HDR1),” Doc. TS 103 433 V1.1.1 (2016-08), ETSI, Sophia Antipolis Cedex, France.
- [62] ITU: “Report ITU-R BT.2446-0 – Methods for conversion of high dynamic range content to standard dynamic range content and vice-versa,” Rep. ITU-R BT.2446-0 (04/2019), International Telecommunication Union, Geneva, Switzerland, <https://www.itu.int/pub/R-REP-BT.2446-2019>
- [63] ITU: “Report ITU-R BT.2407-0 – Colour gamut conversion from Recommendation ITU-R BT.2020 to Recommendation ITU-R BT.709,” Rep. ITU-R BT.2407-0 (10/2017), International Telecommunication Union, Geneva, Switzerland, <https://www.itu.int/pub/R-REP-BT.2407-2017>

3. DEFINITION OF TERMS

With respect to definition of terms, abbreviations, and units, the practice of the Institute of Electrical and Electronics Engineers (IEEE) as outlined in the Institute’s published standards [7] shall be used. Where an abbreviation is not covered by IEEE practice or industry practice differs from IEEE practice, the abbreviation in question will be described in Section 3.3 of this document.

3.1 Compliance Notation

This section defines compliance terms for use by this document:

should – This word indicates that a certain course of action is preferred but not necessarily required.

should not – This phrase means a certain possibility or course of action is undesirable but not prohibited.

3.2 Treatment of Syntactic Elements

This document contains symbolic references to syntactic elements used in the audio, video, and transport coding subsystems. These references are typographically distinguished by the use of a

different font (e.g., `restricted`), may contain the underscore character (e.g., `sequence_end_code`) and may consist of character strings that are not English words (e.g., `dynrng`).

3.2.1 Reserved Elements

One or more reserved bits, symbols, fields, or ranges of values (i.e., elements) may be present in this document. These are used primarily to enable adding new values to a syntactical structure without altering its syntax or causing a problem with backwards compatibility, but they also can be used for other reasons.

The ATSC default value for reserved bits is ‘1’. There is no default value for other reserved elements. Use of reserved elements except as defined in ATSC Standards or by an industry standards setting body is not permitted. See individual element semantics for mandatory settings and any additional use constraints. As currently-reserved elements may be assigned values and meanings in future versions of this Standard, receiving devices built to this version are expected to ignore all values appearing in currently-reserved elements to avoid possible future failure to function as intended.

3.3 Acronyms and Abbreviations

The following acronyms and abbreviations are used within this document.

2D	Two-dimensional
3D	Three-dimensional
3D-TV	Three-dimensional television
8-VSB	8-level Vestigial SideBand modulation
A3P	ATSC 3.0 Physical Layer
AC-3	Dolby Digital Audio Codec
AC-4	Dolby Digital Audio Codec
AEA	Advanced Emergency informAtion
AEAT	Advanced Emergency informAtion Table
AFD	Active Format Description
AL	Alternate Language
ALP	ATSC 3.0 Link-layer Protocol
ASI	Asynchronous Serial Interface
AVC	Advanced Video Coding [MPEG-4 Part 10 H.264]
BSID	Broadcast Stream Identifier
CALM	Commercial Advertisement Loudness Mitigation
CAP	Common Alerting Protocol
CAT	Conditional Access Table
CC	Closed Captions
CDM	Content Decrypt Module
CDN	Content Delivery Network
CEA	Consumer Electronics Association
COFDM	Coded Orthogonal Frequency Division Multiplexing
CTA	Consumer Technology Association
DASH	Dynamic Adaptive Streaming over HTTP
DASH-IF	Dynamic Adaptive Streaming over HTTP Industry Forum

dB	Decibel
DEMUX	Demultiplexer
DLL	Data Link Layer
DRC	Dynamic Range Control
DRM	Digital Rights Management
DTS	Decoding Time Stamp
DTV	Digital Television (ATSC 1.0)
DVS	Descriptive Video Service
E-AC-3	Enhanced AC-3
EAN	Emergency Alert Notification
EAS	Emergency Alert System
EIT	Event Information Table
EMG	Emergency audio
ESG	Electronic Service Guide
ETT	Extended Text Table
FCC	Federal Communications Commission
fps	frames per second
HD	High Definition
HDMI	High-Definition Multimedia Interface
HDR	High Dynamic Range
HEVC	High Efficiency Video Coding [MPEG-H Video H.265]
HFR	High Frame Rate
HLG	Hybrid Log-Gamma
HLS	HTTP Live Streaming
HTML	Hypertext Markup Language
HTTP	Hypertext Transfer Protocol
IEC	International Electrotechnical Commission
I/F	Interface
IMSC1	Internet Media Subtitles and Captions
IP	Internet Protocol
IRDTP	Integrated Receiver Decoder Transcoder Packager
ISO	International Standards Organization
kb/s	Kilobits per second
LFE	Low Frequency Effects
LLS	Link Layer Signaling
LUT	Lookup Table
MAC	Media Access Control
MATV	Master Antenna Television
MD	Metadata
MGT	Master Guide Table
MMT	MPEG Multimedia Transport
MMTP	MMT Payload

MPD	Media Presentation Description
MPEG	Moving Picture Experts Group
MPEG-H	MPEG High Efficiency Coding and Media Delivery in Heterogeneous Environments
MUX	Multiplexer
MVPD	Multichannel Video Programming Distributor
NGA	Next Generation Audio
OSI	Open Systems Interconnection
OTA	Over-The-Air
OTT	Over-The-Top
PAT	Program Association Table
PCM	Pulse Code Modulated
PGM	Program
PHY	Physical layer of OSI model
PID	Program Identification
PKI	Public Key Infrastructure
PLP	Physical Layer Pipe
PMT	Program Map Table
POP	Point of Presence
PQ	Perceptual Quantizer
PSI	Program and System Information
PSIP	Program and System Information Protocol
PTP	Precision Time Protocol
PTS	Presentation Time Stamp
QAM	Quadrature Amplitude Modulation
RF	Radio Frequency
ROUTE	Real-time Object delivery over Unidirectional Transport
SA	Service Authorization
SAP	Secondary Audio Program
SCG	Standard Color Gamut
SCHC	Service-Compatible Hybrid Coded 3DTV
SC-MMH	Service-Compatible 3DTV using Main and Mobile Hybrid delivery
SDI	Serial Digital Interface
SDR	Standard Dynamic Range
SEI	Supplemental Enhancement Information
SFN	Single Frequency Network
SHVC	Scalable High-efficiency Video Coding
SL-HDR1	High Performance Single Layer Directly Standard Dynamic Range (SDR) Compatible High Dynamic Range (HDR) System for use in Consumer Electronics Devices (SL-HDR1) [61]
SLS	Service Layer Signaling
SLT	Service List Table
SMPTE	Society of Motion Picture & Television Engineers

STB	Set-Top Box
STL	Studio-to-Transmitter Link
STT	System Time Table
TCP	Transmission Control Protocol
TS	Transport Stream
TSID	Transport Stream Identifier
TTML	Timed Text Markup Language
TV	Television
TVCT	Terrestrial Virtual Channel Table
UDP	User Datagram Protocol
UHD	Ultra High Definition
URI	Uniform Resource Identifier
USBD	User Service Bundle Description
VCT	Virtual Channel Table
VDS	Video Descriptive Service
VP1	Audio watermarking technology specified in “ATSC Standard: Audio Watermark Emission” [48]
W3C	World Wide Web Consortium
WCG	Wide Color Gamut
XOR	Exclusive Or

3.4 Terms

The following terms are used within this document.

Content – The sum of Essence plus Metadata.

Essence – The primary material constituting an expression of the substance or intent of information being processed, communicated, or stored. Essence is supplemented by Metadata to comprise Content. Examples are audio Essence, video Essence and captions Essence.

Metadata – Information about Essence that describes the Essence itself, the characteristics of expression, communication, or storage of the Essence, or any other information related to the Essence that is not itself Essence. Metadata related to particular Essence can become Essence on its own when there is other Metadata related to it; the classic example of such relationships is closed captioning, which can be considered Metadata related to video and audio Essence but which also can have associated Metadata describing the formatting of the characters used to express the Essence of the captions.

Redistribution – The process of secondary distribution of a primary signal, a signal which has already been distributed.

Simulcast – Signal Redistribution of perceptually the same Content at the same time on multiple frequencies or with multiple resolutions.

Spatial Scalable Coding – A method of providing low and high spatial resolution versions of Content through use of a base layer and an enhancement layer

Translator – A facility created to receive a terrestrial broadcast over-the-air on one frequency and rebroadcast the same or substantially identical signal on another frequency.

4. SYSTEM OVERVIEW

This document describes methods for converting ATSC 3.0 services for Redistribution to legacy environments, including as ATSC 1.0 compatible signals, to MVPDs and other service providers. Readers of this document should be familiar with both ATSC standards. The A/300 [8] ATSC 3.0 System Standard both describes the full ATSC 3.0 system in overview and provides normative requirements for incorporation and use of the various subsystems of ATSC 3.0 in the context of the overall system². A comparable description of ATSC 1.0, without normative requirements, appears in A/53 Part 1, “Digital Television System” [1].

Figure 4.1 illustrates an overview of the functional blocks involved in converting an ATSC 3.0 signal for Redistribution.

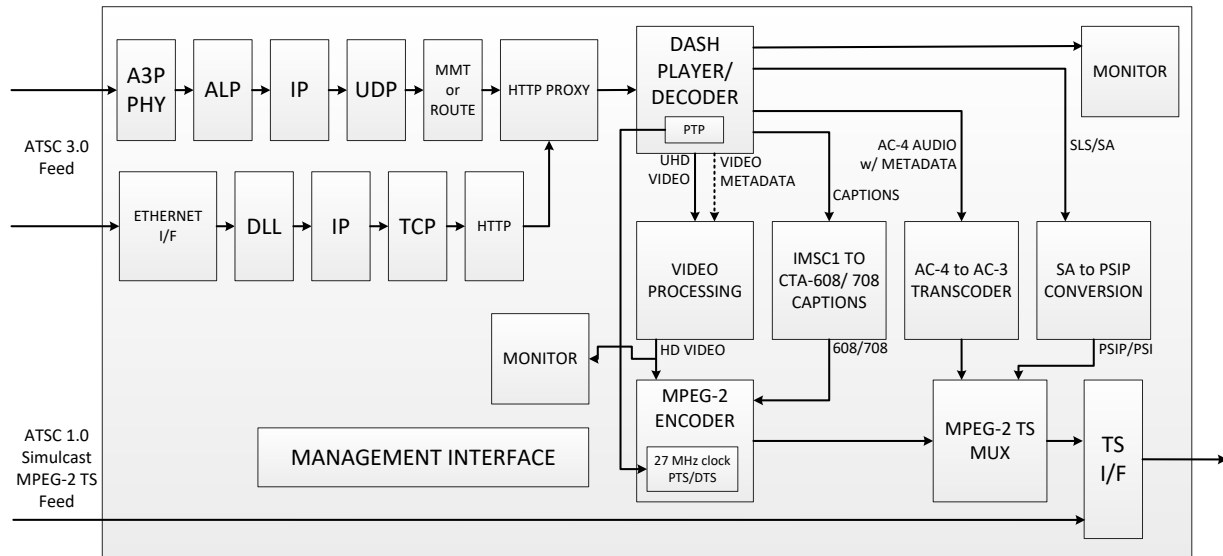

Figure 4.1 Block diagram of ATSC 3.0 conversion for Redistribution.

Converting an ATSC 3.0 signal for Redistribution generally requires receiving and decoding the ATSC 3.0 signal to its video, audio and captioning Essence streams and transcoding or re-encoding them as an ATSC 1.0 or legacy signal. Figure 4.2 shows a conceptual view of the ATSC 3.0 system layers and the ATSC 1.0 system layers that are traversed in the conversion process. As described by the Use Cases discussed in this document, an ATSC 3.0 input signal may be an RF signal that requires tuning and demodulation, or it may be on an IP interface. Similarly, an ATSC 1.0 output signal may be an RF signal or an MPEG-2 Transport Stream on an ASI or IP interface.

Conceptually, handling the full generality of possible ATSC 3.0 inputs and ATSC 1.0 or legacy outputs is most easily understood as requiring a complete decode and re-encode process, illustrated in Figure 4.2. However, in practical implementations (which may be limited in terms of the video format combinations that are converted), transcoding might provide an alternate means to full decode of HEVC [10] to baseband and re-encoding with MPEG-2.

² As previously noted in the Introduction and Background, not all features of the ATSC 3.0 Standards are supportable for conversion to ATSC 1.0 or other legacy systems given the fundamental differences and incompatibilities from old to new standards. Each section of this document provides details for where these incompatibilities and differences exist so as to help in the conversion and Redistribution efforts.

Also of note is that closed caption conversion might be greatly simplified if optional 608/708 caption data is included in the ATSC 3.0 transmission. If only the required IMSC1 [11] captioning is present, then it must be converted to the 608/708 syntax that is required in ATSC 1.0.

Although it is possible for conversion to render certain HTML5 [12] elements from interactive Content for broadcast, such conversions are not recommended and should only be performed in close collaboration with the broadcaster.

There are many details and considerations in the conversion of Essence as described in the following sections of this document.

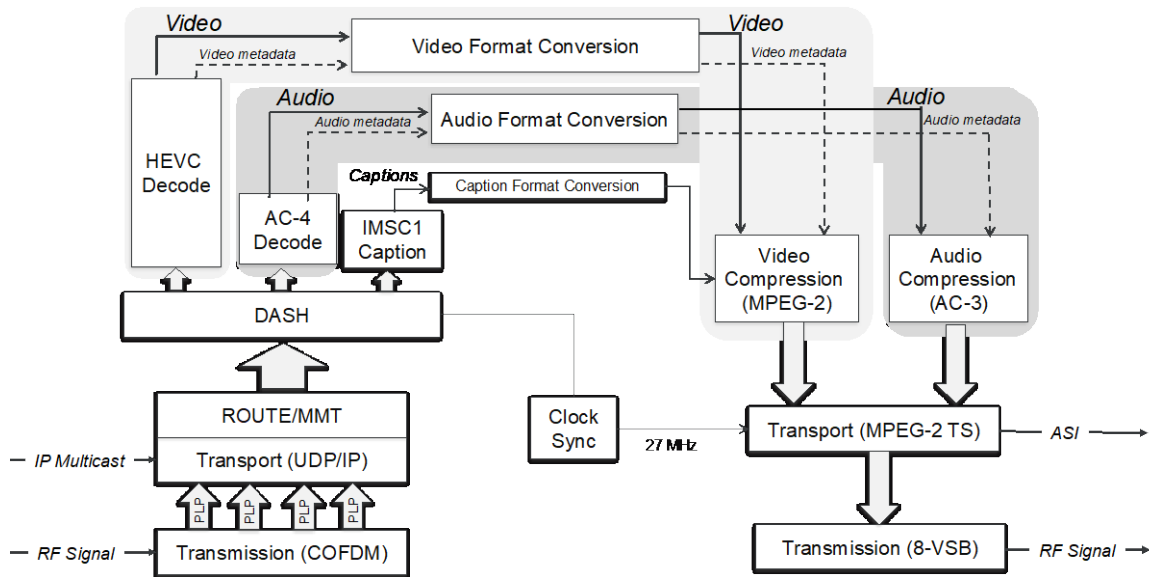

Figure 4.2 Conceptual signal flow for conversion of video, audio, and captions Essence.

4.1 Conceptual Integrated Receiver Decoder Transcoder Packager (IRDTP)

This section proposes the concept of a system processor for the purpose of converting ATSC 3.0 signals for delivery to MVPDs. The following sections with descriptions of the blocks, objects, labels and interface wires for the companion drawing in Section 4.2 provides the high-level processing steps and interfaces in a proposed IRDTP, shown in Figure 4.4.

- Section 4.3 provides the descriptions of the high-level blocks (color-shaded sections).
- Section 4.4 provides the descriptions of the individual processes (sub blocks) in each of the high-level blocks.
- Section 4.5 provides the descriptions for all the interfaces between processes and device input and outputs.
- Section 4.2 is the proposed detail drawing itself.

The diagram in Figure 4.3 describes the expected delivery paths and the placement of the proposed device or processor to address all of the possible signal flow delivery output options. The intent of the proposed device is to provide a range of delivery choices derived from ATSC 3.0 broadcast for delivery into the MVPD environment. The IRDTP can be designed to handle multiple broadcast services and signals. Multiple configuration types for the ATSC 3.0 signal inputs, including possible additional modifications to these configurations over time, should be

considered. Broadcasters should consider that profile changes, video transfer characteristic, dynamic range, and color space changes, HDR system changes, display aspect ratio changes, frame rate changes, and interlaced/progressive transitions (in either order) should be avoided as they may result in temporary disruption of the IRDTP video output.

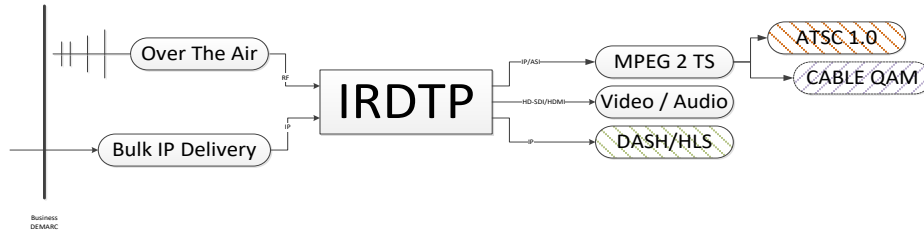

Figure 4.3 IRDTP operation.

The Content from a broadcaster is received from the TV station transmitter or from a direct connection between the station and the local MVPD point of presence (POP). For the direct connection, there is a choice on codec, bit rate, and transport configurations. The choice should preserve the highest source quality feed possible, up to uncompressed video over IP, without oversubscribing the network connection while minimizing the number of re-encodes of the signal necessary to create a compatible input signal to the conversion process. The direct feed might support more than just the ATSC 1.0 signal (e.g. an additional HDR channel) for simulcasting purposes, and the input source quality should be higher than anticipated output signals. Providing similar MPEG-2 TS transport configurations to the output ATSC 1.0 signal might aid in the speed and simplification of conversion including transference of the metadata to the output signal.

From the viewpoint of the local MVPD, the POP would need to simultaneously handle content from multiple broadcasters in a regional market on either interface (OTA and direct connection), and to be switchable to either interface for redundancy strategies. The capabilities may vary dependent upon the available equipment and capabilities of the broadcaster and MVPD.

The ATSC 3.0 station may also choose to deliver Content in other formats to the MVPD to support other business models. The direct connection in this case is the ATSC 3.0-only Content bound for the OTT path, details of which are out-of-scope for this recommended practice.

The Conceptual IRDTP described in this section is a hypothetical processor that receives ATSC 3.0 services. This hypothetical processor can re-package ATSC 3.0 services into a different streaming format decoded to baseband and/or transcoded into one or more traditional MPEG-2 TS formats.

4.2 IRDTP Conceptual Diagram

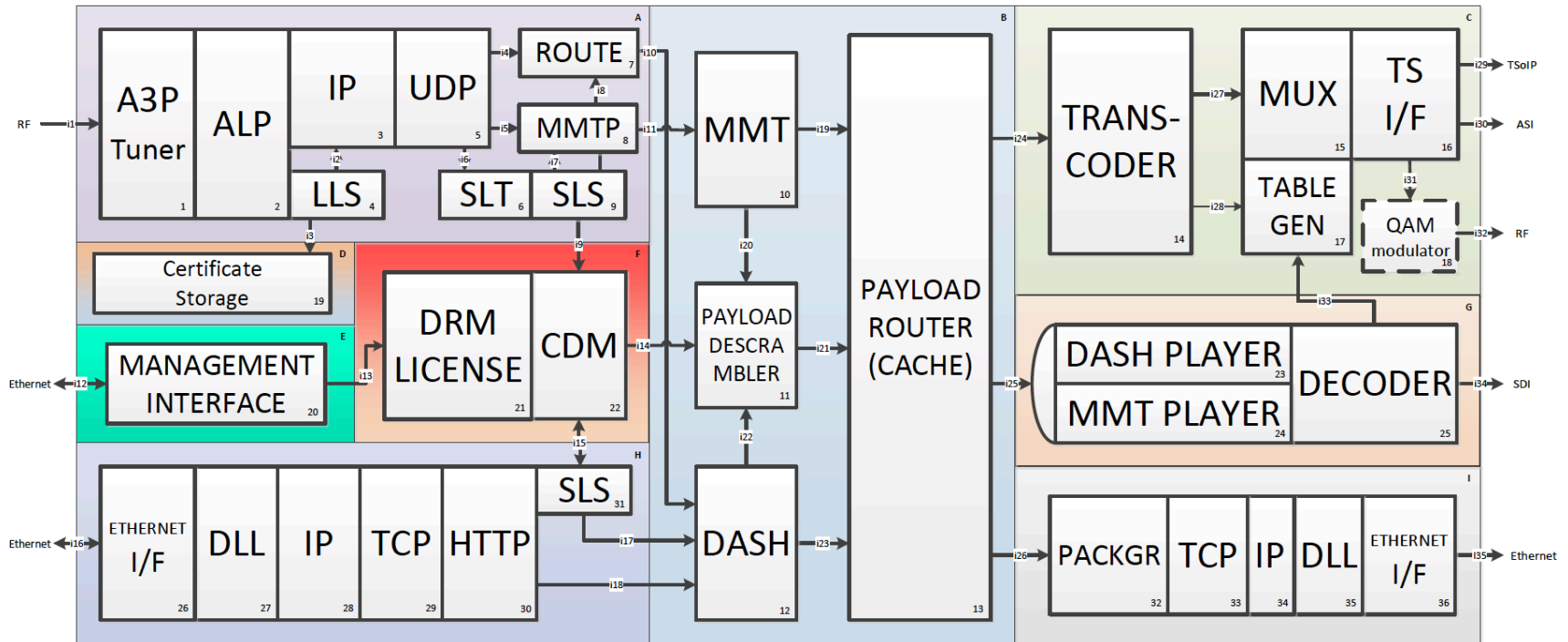

Figure 4.4 IRDTP process flow.

4.3 IRDTP BLOCK Descriptions

The following descriptions are the descriptions of the color-shaded block sections of Figure 4.4 containing the smaller blocks, described in Section 4.2.

- A RF TUNER / RECEIVER – Connected to an antenna for reception of the main, off-air signal to tune in the specific on-air service and deliver the payload output types to the required delivery points.
- B DATA PAYLOAD DESCRAMBLER AND ROUTER – A service descrambler to convert Content into clear services based on entitlements delivered from the CDM, and pass the recovered packets to a CACHE to deliver into any of the downstream processes for further processing.
- C TRANSCODER TO MPEG TS OUTPUT – Selected services are transcoded with the appropriate output properties to support the MVPD service delivery requirements including any PSI tables to make a compliant output.
- D Certificate Store – Storage for PKI Certificates.
- E MANAGEMENT INTERFACE – Used for the control of the configuration and access and input of licenses.
- F DRM LICENSE and CDM – Rights and entitlements are managed to process protected services and decipher encrypted keys to allow access to services that are not in the clear.
- G PLAYER / DECODER – For decoding selected services back to baseband output, video and audio(s) for connecting into the MVPD video router.
- H DIRECT IP INPUT from the BROADCASTER – This input provides a direct IP connection to the TV station and may or may not have ROUTE/DASH wrapper or MMT bundled in the delivery path. This input may simply be a MPEG-2 TS delivery of the same or modified output from the transmitter. This input could also be from a CDN-connected delivery service.
- I PACKAGER OUTPUT for DELIVERY OVER HTTP – The MVPD may choose to re-wrap the Content for delivery inside an internal CDN capability to enable OTT delivery capability.

4.4 IRDTP MODULE Descriptions

- 1 A3P Tuner – The ATSC 3.0 RF tuner input port to receive the broadcast carrier.
- 2 ALP – Process to parse PHY layer data to form ALP packets to be output into the IP payload.
- 3 IP – Receives IP packets and unwraps them into the UDP sockets layer.
- 4 LLS – Link Layer Signaling – Process to parse tuning information for tuning IP payload data. LLS information must be verified using PKI operations per A/360 [45].
- 5 UDP – Receives UDP ports for delivery into SLT, ROUTE or MMT processes.
- 6 SLT – Parses the SLT message to indicate which of the payload(s) to process.
- 7 ROUTE – Session process to tune into announced DASH programs.
- 8 MMTP – Session process to tune into announced MMT programs.
- 9 SLS – Parses SLT message to provide pointers to the 3 process types available. SLS information must be verified using PKI operations per A/360 [45].
- 10 MMT – Process to unwrap MMT sessions and pass those payloads to the processes (e.g. decode).
- 11 PAYLOAD DESCRAMBLER – Scrambled service streams are XOR'd with deciphered entitlement keys to make clear bytes, not to be confused with decryptor (CDM, #20).

- 12 DASH – Parses MPD announcements for DASH segments to be unwrapped (clear or scrambled).
- 13 PAYLOAD ROUTER (CACHE) – Receives Content to be distributed to the various processes for output delivery.
- 14 TRANSCODER – Processes to convert payload(s) from one format into one or more different format(s).
- 15 MUX – Assigns MPEG PID values and integrates tables to make a compliant TS output.
- 16 TS I/F – Applies the TS packets into one or more output types (IP or ASI).
- 17 TABLE GEN – Creates compliant tables for injection to the multiplexer.
- 18 Optional QAM Modulator – Modulates to QAM from TS input.
- 19 Certificate Store – Collection of all PKI certificate data used to maintain operations of the IRDTP as expressed to the user via the management interface, accessed and used by internal processes.
- 20 MANAGEMENT INTERFACE – Allows users to set up and control the runtime environment.
- 21 DRM LICENSE – Manages the Content rights, entitlements and certificates, to support decryption keys.
- 22 CDM – Content Decrypt Module – Deciphers the encrypted Content based on entitlements.
- 23 DASH PLAYER – Plays out a DASH session to baseband video and audio.
- 24 MMT PLAYER – Plays out a MMT session to baseband video and audio.
- 25 DECODER – Renders the session play-out to produce video and audio output.
- 26 ETHERNET INPUT I/F – Accepts the physical Ethernet interface.
- 27 DLL – Maps the MAC address for source-specific packets.
- 28 IP – Maps the IP address for source-specific packets.
- 29 TCP – Maps to the TCP port for source-specific packets.
- 30 HTTP – Server that hosts web Content from the SLT tuner and available DASH services.
- 31 SLS – Technique for delivering tuning information to find the DASH service(s).
- 32 PACKGR – Wraps the payload session segments and chunks in a DASH or HLS wrapper.
- 33 TCP – Binds the assigned outbound TCP socket value.
- 34 IP – Binds the IP address to the origin server payload.
- 35 DLL – Binds the MAC address to the IP payload.
- 36 ETHERNET OUTPUT I/F – Binds to the DLL to the physical Ethernet interface.

4.5 IRDTP INTERFACE Descriptions

- i1 RF Input – Provides a 75 ohm input to the A3P Tuner.
- i2 LLS tuning information to direct the IP address process to select specific traffic. LLS information must be verified using PKI operations per A/360 [45] (Certificate Store, #36).
- i3 LLS to Certificate Store – Validates the PKI certification to allow transport and decryption.
- i4 UDP to ROUTE – A path from the UDP port to deliver ROUTE-specific packets.
- i5 UDP to MMTP – A path from the UDP port to deliver MMT-specific packets.
- i6 SLT parsed data to deliver SLS messages to be selected. SLS information must be verified using PKI operations per A/360 [45] (Certificate Store, #36).
- i7 SLS to MMTP – Instructs the MMTP process where to find the MMT-specific payloads.
- i8 SLS to ROUTE – Instructs the ROUTE process where to find the DASH-specific payloads.

- i9 SLS to CDM – Carries the service entitlement payloads to grant access rights and user key(s).
- i10 ROUTE – Delivers DASH payloads for unwrapping at the DASH process.
- i11 MMTP – Payload to be parsed for MMT Content.
- i12 Ethernet for Control and Management – For user interface configuration and monitoring of device.
- i13 User-entered entitlements from the management interface (e.g. fixed key).
- i14 Decrypting Instructions – Includes deciphered keys from DRM rights objects.
- i15 SLS packets with CDM messages for entitlement rights or DRM wrapped objects.
- i16 Ethernet input for Broadband Connection – For direct connection to an ATSC 3.0 TV station system and may contain more than one delivery type or format.
- i17 SLS output to direct the DASH process the specified broadband-delivered Content.
- i18 Broadband-delivered Content to be presented to the DASH process.
- i19 Clear MMT payload for delivery to the payload router.
- i20 Scrambled MMT payload output fed to the payload decryptor for decryption.
- i21 Decrypted payload output from either DASH or MMT.
- i22 Encrypted DASH payload output fed to the payload decryptor for decryption.
- i23 Clear DASH payload output for delivery to the payload router.
- i24 Raw payload output to feed the transcoder subsection.
- i25 Raw payload output to the player/decoder subsection.
- i26 Raw payload output to feed the packager output subsection.
- i27 Transcoder output to feed ATSC 1.0 compliant Content into the mux process.
- i28 Transcoder extracted Metadata useful for PSI/PSIP production.
- i29 TS over IP output from the mux output (may contain one or more TS over unicast or multicast).
- i30 ASI output from the mux output (a single TSID).
- i31 Transport Stream output to drive the (optional) QAM modulator RF output.
- i32 QAM RF channel output (optional).
- i33 Decoder Metadata useful for PSI production.
- i34 Uncompressed SDI output from the decoder with embedded audio and SMPTE captions.
- i35 Ethernet output of packager published Content to feed into a CDN origin server.

5. NON-CONVERTED ATSC 3.0 FEATURES

ATSC 3.0 is a more advanced television broadcast system than ATSC 1.0. As such, some features of ATSC 3.0 emissions are not recommended to be, or cannot be, converted into an ATSC 1.0 compliant emission.

- Supplemental Emergency Information – As per FCC regulations, ATSC 3.0 emissions are expected to carry Emergency Alert Notifications (“EAN” or “Presidential Message”), and might also provide emergency information messages as “burned-in crawls” and accompanying audio, just as ATSC 1.0 emissions do today; ATSC 3.0 emissions might also include supplemental advanced emergency information (“ATSC 3.0 AEA”); it is recommended that the conversion process preserve the EAN, and burned-in crawl, and accompanying audio, but not attempt any conversion of ATSC 3.0 AEA, which is supplemental information.

- Interactivity – Although ATSC 2.0 includes interactivity and is backward compatible with ATSC 1.0, it is recognized that the ATSC 3.0 interactive system is very different from the ATSC 2.0 interactive system; it is generally not recommended that ATSC 3.0 interactive features be converted to ATSC 2.0 interactive features when converting to an ATSC 1.0 format (See Section 11 on Interactive Content).
- Non-real-time Content – ATSC 3.0 provides a means for delivering non-real-time Content which can be ESG data files, advanced supplementary emergency information data files or interactivity data files; given that AEA and interactivity features are not expected to be converted and given that MVPDs typically provide ESG data independent from what is in the broadcast emission, it is not recommended that non-real-time Content be converted when converting a ATSC 3.0 emission to an ATSC 1.0 emission.

6. RECEPTION AND SERVICE IDENTIFICATION

Reception and decoding of ATSC 3.0 services for delivery as ATSC 1.0 signals requires an understanding of the coded representation of the desired ATSC 3.0 services and their associated physical, management, and protocol layers of the ATSC 3.0 signal, and their relationships to a desired ATSC 1.0 signal. This section provides details on these relationships along with the conversions that might be necessary.

6.1 Physical Layer

6.1.1 A/321: System Discovery and Signaling

The A/321 [13] document describes the system discovery and signaling architecture for the ATSC 3.0 physical layer. Broadcasters anticipate providing multiple wireless-based services, in addition to conventional broadcast television in the future. Such services might be time-multiplexed together within a single RF channel. The bootstrap provides a universal entry point into a broadcast waveform.

ATSC 1.0 does not have a comparable specification. ATSC 1.0 performs a similar function with the Data Field Sync as defined in A/53, Part 2 [1]. However, this information is not likely to be utilized in MVPD distribution.

6.1.2 A/322: Physical Layer Protocol

The A/322 [14] Standard describes the RF/Transmission of a physical layer waveform. This waveform enables flexible configurations of physical layer resources to target a variety of operating modes. A desired ATSC 3.0 service might be composed of IP-based data streams that are transmitted on up to four different Physical Layer Pipes (PLPs, where each PLP represents a specific data stream within the physical layer waveform), and/or internet-delivered streams. The comparable capabilities in ATSC 1.0 are included in A/53 Part 2, “RF/Transmission System Characteristics” [1].

6.1.3 A/323: Dedicated Return Channel for ATSC 3.0

A/323 [15] specifies both the physical layer and MAC (Media Access Control) layer for the ATSC 3.0 Dedicated Return Channel. The Dedicated Return Channel supports interactive services in ATSC 3.0 without dependence on other network infrastructure.

ATSC 1.0 does not have a comparable specification.

6.1.4 A/324: Scheduler/Studio to Transmitter Link

The A/324 [16] document specifies the protocol on the Single Frequency Network (SFN) interface from studio side infrastructure to SFN of transmitters. The document also defines possible interfaces among the studio infrastructure, for example the interconnection of the ATSC Link-layer Protocol (ALP) and a Broadcast Gateway.

ATSC 1.0 does not have a comparable specification. ATSC 1.0 performs some similar functions relevant to SFNs and STLs defined in A/110 [17]. However, this information is not likely to be utilized in MVPD distribution.

6.2 Management and Protocols Layer

6.2.1 A/330: Link-Layer Protocol

The A/330 [18] standard defines the ATSC Link-layer Protocol (ALP). ALP corresponds to the data link layer in the OSI 7-layer model. ALP provides a path to deliver IP packets, link layer signaling packets, and MPEG-2 Transport Stream (TS) packets down to the RF Layer for transmission and back, after reception.

ATSC 1.0 does not have a comparable specification.

6.2.2 A/331: Signaling, Delivery, Synchronization, and Error Protection

A/331 [19] specifies the technical mechanisms and procedures pertaining to service signaling and IP-based delivery of a variety of ATSC 3.0 services and Content to ATSC 3.0-capable receivers over broadcast, broadband and hybrid broadcast/broadband networks. The service signaling functionality defines the data formats and information components necessary to discover and acquire user services.

Some comparable capabilities in ATSC 1.0 are included in A/53 Part 3 “Service Multiplex and Transport Subsystem Characteristics” [1] and A/65 “Program And System Information Protocol For Terrestrial Broadcast And Cable” [20]. The AC-3 Audio Descriptor, the E-AC-3 Audio Descriptor and other transport-level descriptors are defined in A/52, “Digital Audio Compression (AC-3) (E-AC-3) Standard” [5].

6.2.3 A/332: Service Announcement

The normative portions of A/332 [21] define a standard for announcement of services in an ATSC 3.0 broadcast and define the data formats and delivery mechanisms used to announce the Content and services being delivered, or scheduled for delivery, in ATSC 3.0. Within A/332, information is associated with a service using a `@globalServiceID` attribute. This attribute is a globally-unique URI value that identifies the information associated with a service throughout ATSC 3.0 signaling and announcement. Specifically, the `@globalServiceID` attribute defined within each service specification of the SLT (A/331) [19] binds the service announcement information to the broadcast defined by a broadcast ID (`@BSID`). In addition, the SLT service contains a `@serviceId` attribute that binds various service-level signaling (SLS) data structures to the service and, thus, the announcement data through the `@globalServiceID` attribute. The `@serviceId` 16-bit integer value is required to be unique within the scope of the broadcast area.

Some comparable capabilities in ATSC 1.0 are included in A/65 “Program and System Information Protocol for Terrestrial Broadcast and Cable” (PSIP) [20]. While ATSC 3.0 can provide significantly more service announcement information, the text portions of the announcement data can be used to construct PSIP announcement information nominally contained in the VCT, EITs and ETTs. Within PSIP, the `source_id` value provides a similar role to the `SLT.@serviceId`. It is recommended that the `@serviceId` be used as the `source_id` when

constructing the PSIP information derived from ATSC 3.0 sources. The announcement and signaling data is bound to a service within PSIP by providing the `source_id` along with other information, including the TSID, within the VCT. Further, EITs and ETTs contain the `source_id` in their table headers to allow them to easily be matched to a given service.

Table 6.1 shows the recommendations for the signaling of services when translating from ATSC 3.0 to ATSC 1.0.

Table 6.1 Recommendations for the Signaling of Service Elements in the Translation from ATSC 3.0 to ATSC 1.0

Signal of Origin [baseband]	ATSC 3.0 Transmission	ATSC 1.0 Retransmission Version
Resolution: 2160p, 1080p, 1080i, 720p or 480i (HEVC, AVC, MPEG-2 Video)	Resolution: 2160p, 1080p, 1080i, 720p or 480i	MPEG-2 Video or AVC Resolution: 1080i, 720p or 480i. Native resolutions (1080i, 720p, 480i) to ATSC 1.0 are able to pass through; others need to be converted. For codecs, MPEG-2 Video is supported per ATSC 1.0 specs. AVC and baseband video (SMPTE-292M) [22] can be supported. Any delivered ATSC 3.0 stream that is not a native resolution of ATSC 1.0 needs to undergo a conversion*.
Audio Type: AC-4 [23] Surround at select data rates plus SAP and Descriptive Audio Encoded AC-4	Audio Type: AC-4 Surround at select data rate plus SAP and Descriptive Audio Encoded AC-4	Required to support audio in ATSC 1.0 for main, secondary, and descriptive audio types*. Audio DVS needs to be supported within two audio channels. The multiple audios delivered by a programmer can be, for example, an English complete main, a Spanish complete main, an English VDS, and an optional Spanish/English-VDS mix to support legacy 2-channel set tops. The actual languages used for a particular programmer are examples as there could be others or even additional languages. The first three audios can be statically encoded with an industry-defined ISO/ATSC descriptor and made available to consumers as a one-time opt-in choice. English will always be provided as "fill" when the desired language is not available.
2094 Metadata [24]	2094 Metadata	There is no display-optimized Metadata in ATSC 1.0 signals*.
Transfer Function/Color Space: HDR 2084 [25] / Rec. ITU-R BT.2020 [26] or HDR HLG [27] / Rec. ITU-R BT.2020 or SDR / Rec. ITU-R BT.709 [28]	Transfer Function/Color Space: HDR 2084 / Rec. ITU-R BT.2020 or HDR HLG / Rec. ITU-R BT.2020 or SDR / Rec. ITU-R BT.709	Transfer Function/Color Space: SDR/Rec. ITU-R Rec 709, 8 bits. ATSC 1.0 signals support receivers with Rec. ITU-R BT.1886 [29] Transfer Function and Rec. ITU-R BT.709 [28] color space using codeword range supported by 8 bits*.
Active Format Description (AFD) and Bar Data	A/341 Section 6.4.2 [30] Carriage of AFD in HEVC (SEI message)	ATSC A53 Part 4, Sec 6.2.4.2 [3] AFD carried in the picture user data of the MPEG 2 video transport packets
Closed Captions 608/708	Closed Captions embedded in IMSC1	Closed Captions 608/708 [6] embedded in picture user data*.
Electronic Program Guide	Electronic Program Guide	Electronic Program Guide A/65 [20]. ATSC 3.0 A/332 might be stripped out or converted to EITs as called for in ATSC 1.0*.
Emergency Alert Graphics Overlay and Audio Track (Required EAS)	Emergency Alert Graphics Overlay and Audio Track (Required EAS)	Emergency Alert Graphics Overlay and Audio Track (Required EAS) must be burned in to the video/audio

Advanced Emergency informAtion (AEAT Table)	Advanced Emergency informAtion (AEAT Table)	AEA is not intended to replace current FCC emergency messaging regulations. It is expected that stations will fulfill their obligations regarding EAS in the same way as with ATSC 1.0, and stations that employ “burned-in” banners and audio for non-EAS emergency messages might continue with that practice as with ATSC 1.0. The ATSC 3.0 AEA system enables broadcasters to provide a rich set of supplemental information, however that information is incompatible with ATSC 1.0 systems, and therefore automatic conversion is unlikely to be successful.
Visual and Audio Watermarks	Visual and Audio Watermarks	Visual and Audio Watermarks: Might be removed, overwritten, or passed on*.
Signaling not required beyond SMPTE 2016 [31] data	Signaling required to instruct the receiver how and what to decode.	Signaling delivered from ATSC 3.0 transmission utilized to create an optimized ATSC 1.0 image, if extracted from ATSC 3.0, then passed on into the ATSC 1.0 signal*.
PSIP data: PAT, PMT, CAT, TVCT, VCT, STT, MGT, EIT, ETT (per service)	Signaling data: SLT, USBD, BSID, SLS, ESG, System Time Fragment [per service]	PSIP data: PAT, PMT, CAT, TVCT, VCT, STT, MGT, EIT, ETT (per service) needs to be extracted from ATSC 3.0 and recreated for ATSC 1.0 signals*.
*Contractual agreements may affect the scope of all possible conversions and approaches detailed in the table, and are outside the scope of this document.		

6.2.4 A/333: Service Usage Reporting

The normative portions of A/333 [32] define a standard for service usage reporting for ATSC 3.0. A service usage data gathering system consists of three main areas: service usage information collection; service usage information storage (persistent or transient); and reporting the stored information.

No conversion is needed since ATSC 1.0 does not have this capability. It should be noted that A/105 [33] describes mechanisms for Service Usage Reporting that are backward compatible with ATSC 1.0 and may be possible to include, if desired.

6.2.5 A/337: Application Signaling

The A/337 [34] document specifies the signaling of application properties and synchronization of application actions with underlying audio/video Content. It specifies mechanisms for signaling the properties of applications, including their lifecycle states, and also mechanisms for delivering activation notifications synchronized with a time base, so that the actions of applications can be synchronized accordingly.

No conversion is needed since ATSC 1.0 does not have this capability. A/105 [33] provides for an interactive Content environment and thus also information about application signaling; however, it should be noted that the A/337 and A/105 systems are not very similar to one another.

7. APPLICATIONS AND PRESENTATION LAYER

7.1 Video Processing

The A/341 [30] Standard describes the video coding constraints on Rec. ITU-T H.265 | ISO/IEC 23008-2 “HEVC” [10] video compression in the ATSC 3.0 Digital Television System.

The comparable capabilities in ATSC 1.0 are included in A/53 Part 4 “MPEG-2 Video System Characteristics” [3] and A/72 “Video System Characteristics of AVC in the ATSC Digital Television System” [35].

ATSC 3.0 video utilizes a variety of format parameters that ATSC 1.0 does not enable. A number of facets of conversion may be necessary for video signals.

Such conversions might include:

- Compression Codec
- Selecting from among multiple video streams in the ATSC 3.0 service, which might require:
 - Identifying which is the “main” video service
 - Converting one or more ancillary video streams
 - For SHVC video: selecting base layer only, or the combined base and enhancement
 - Converting 3D service to the ATSC 1.0 3D or 2D format
- Aspect Ratio handling
- Up- or down-conversion of Spatial Resolution
- Up- or down-conversion of Frame Rate
- Conversion of video transfer characteristic (Rec. ITU-R BT.2020 [26], HDR-HLG, HDR-PQ, Rec. ITU-R BT.709 [28])
- Conversion of Color Space
 - Wide Color Gamut (WCG) to Standard Color Gamut (SCG) re-mapping
- Conversion of Scanning Format (Progressive, Interlaced)
- Conversion of Sample Bit Depth (10, 8 bits)
- Conversion from Full Range or Narrow Range coding (where used for PQ)
- Insertion of 608/708 Closed Captions (see Section 7.3)

In addition, A/341 optionally allows scalable coding (SHVC) representations of video. When an ATSC 3.0 service uses spatially scalable coding, an understanding of the desired ATSC 1.0 video format as well as the resolutions of the base layer and the enhancement layer that are available in the ATSC 3.0 service should be considered to determine the appropriate conversion processes. For example, if the ATSC 3.0 base layer is equal or higher resolution than the desired ATSC 1.0 video format, simply using the ATSC 3.0 base layer for conversion should suffice. If the base layer is lower-resolution than the desired ATSC 1.0 video format, the best quality will be obtained by decoding both base and enhancement layers to reconstitute the higher-resolution video format, which might then be down-converted to the ATSC 1.0 video format. However, it is possible that some conversions will simply use an ATSC 3.0 base layer even if it is a lower resolution that is up-converted to a higher-resolution ATSC 1.0 video format.

A/341 requires the use of temporal sub-layering for High Frame Rate video at 2160p resolution, but the use of this technique at lower resolutions is optional. When an ATSC 3.0 service uses temporal sub-layering, it is appropriate to simply discard (or not to decode) every other frame in the sequence in order to convert the ATSC 3.0 high frame rate video to a one-half frame rate ATSC 1.0 video format. If temporal sub-layering is not used, down-conversion to the lower frame rate should use appropriate motion processing techniques in order to avoid motion judder.

A/341 also optionally allows HDR WCG video in either the PQ or HLG transfer characteristic to be coded with an SL-HDR1 representation as an SDR Rec. ITU-R BT-709 video signal and SL-HDR1 Metadata to guide reconstruction of an HDR WCG video signal. When an ATSC 3.0 service uses SL-HDR1, no further conversion of dynamic range or color space is needed to derive an ATSC 1.0 video format.

Spatial scalability coding, temporal sub-layering and SL-HDR1 encoding may be used in any combination by an ATSC 3.0 service. Fully decoding and reconstructing the highest quality ATSC 3.0 video format and then down-converting to an ATSC 1.0 video format should usually result in

the highest conversion quality. However, for some ATSC 3.0 service configurations and desired ATSC 1.0 video formats, the use of a base layer alone might provide sufficient quality while reducing the complexity of conversion.

Complete details of the processing to implement the many aspects of video format conversions that might be required are beyond the scope of this document, but some of the considerations are outlined and discussed in Annex A, Video Format Conversion Considerations. Designers of conversion systems will choose detailed conversion processes that are appropriate for the quality and complexity considerations of any particular use case (e.g., conversion for MVPD retransmission, OTA Simulcasting, consumer STBs, OTA Translators, MATV systems, etc.) appropriate for their product. Users of conversion systems should understand that various conversion algorithms are possible and they should evaluate the quality of conversion systems to ensure their suitability for particular format choices and use cases.

7.1.1 3D Video

A/341 specifies service compatible type stereoscopic 3D-TV service. Figure 7.1 describes the reference view and the additional view of ATSC 3.0 stereoscopic 3D video components can be delivered via same or separate PLPs.

Some comparable capabilities in ATSC 1.0 are included in Doc. A/104 Part 2 “3D-TV Terrestrial Broadcasting, Part-2 – Service Compatible Hybrid Coding Using Real-Time Delivery” [36] and Doc. A/104 Part 5, “3D-TV Terrestrial Broadcasting, Part 5 – Service Compatible 3D-TV using Main and Mobile Hybrid Delivery” [37].

Considering stereoscopic 3D service scenarios of ATSC 3.0, the conversion of ATSC 3.0 3D video to ATSC 1.0 3D video format would be required as the following:

- Stereoscopic 3D service mode using HEVC:
 - When ATSC 3.0 3D video components are delivered via ATSC 1.0 fixed TV on a single channel (8-VSB transmission only), ATSC 3.0 stereoscopic 3D video encoding and format for reference view and additional view service signaling parameters should be converted to SCHC 3D video encoding and format as specified in A/104 Part 2, Section 4.2: Encoding & Decoding, Section 4.3: Video Format, and Section 4.6 Signaling for SCHC.
 - When ATSC 3.0 3D video components are delivered via ATSC 1.0 fixed TV and mobile TV hybrid 3D transmission (8-VSB and mobile hybrid transmission), ATSC 3.0 stereoscopic 3D video encoding and format for reference view and additional view should be converted to SC-MMH 3D video encoding and format as specified in A/104 Part 5 Section 4.2: Encoding & Decoding, Section 4.3: Video Format and Section 4.7 Signaling for SC-MMH.

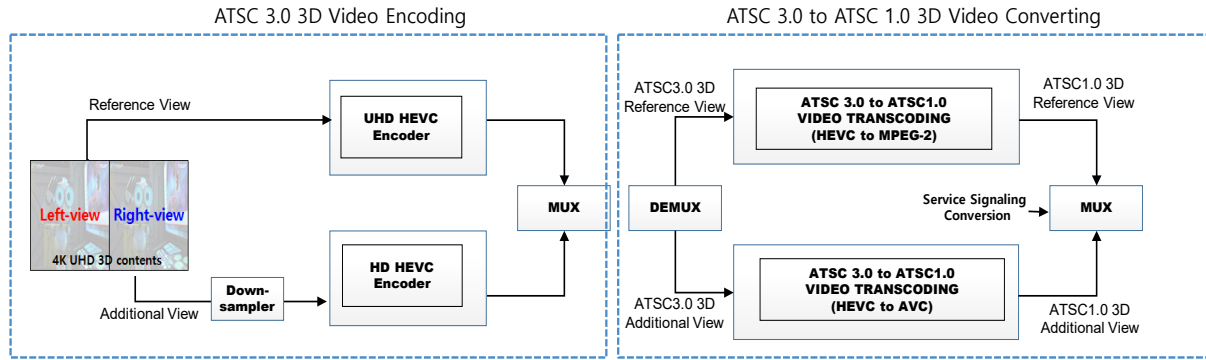

Figure 7.1 Example of ATSC 3.0 to ATSC 1.0 3D video format conversion - 3D service mode using HEVC.

- Stereoscopic 3D service mode using SHVC:
 - In order to obtain the ATSC 3.0 3D additional view image, which is the input of the ATSC 3.0 to ATSC 1.0 video transcoding block in Figure 7.2, only base layer stream should be used for SHVC video decoding.
 - In order to obtain the ATSC 3.0 3D reference view image, which is the input of the ATSC 3.0 to ATSC 1.0 video transcoding block in Figure 7.2, both base and enhancement layer streams should be used for SHVC video decoding.
 - When ATSC 3.0 3D video components are delivered via ATSC 1.0 fixed TV on a single channel (8-VSB transmission only), ATSC 3.0 stereoscopic 3D video encoding and format for reference view and additional view, service signaling parameters should be converted to SCHC 3D video encoding and format as specified in A/104 Part 2, Section 4.2: Encoding & Decoding, Section 4.3: Video Format, and Section 4.6: Signaling for SCHC.
 - When ATSC 3.0 3D video components are delivered via ATSC 1.0 fixed TV and mobile TV hybrid 3D transmission (8-VSB and mobile hybrid transmission), ATSC 3.0 stereoscopic 3D video encoding and format for reference view and additional view, signaling parameters should be converted to SC-MMH 3D video encoding and format as specified in A/104 Part 5 Section 4.2: Encoding & Decoding, Section 4.3: Video Format and Section 4.7 Signaling for SC-MMH.

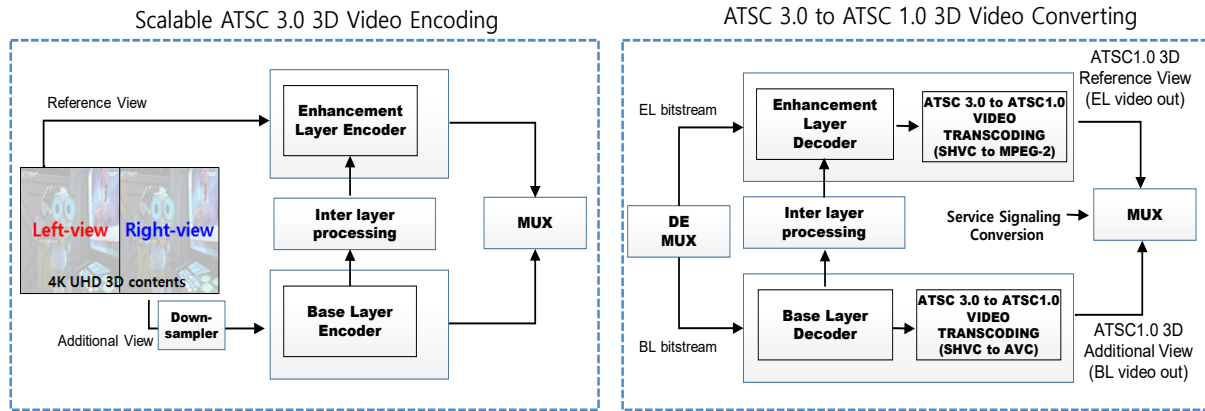

Figure 7.2 Example of ATSC 3.0 to ATSC 1.0 3D video format conversion - 3D service mode using SHVC.

7.2 Audio Processing

7.2.1 ATSC 3.0 Audio Standards

7.2.1.1 A/342 Part 1: Audio Common Elements

A/342 Part 1 [38] specifies the common framework for ATSC 3.0 Audio. It is intended to be used in conjunction with the specific audio technologies described in subsequent parts of that Standard.

Some comparable capabilities in ATSC 1.0 are included in A/52 “Digital Audio Compression (AC-3) (E-AC-3) Standard” [5], A/53 Part 5 “AC-3 Audio System Characteristics,” and A/53 Part 6 “Enhanced AC-3 Audio System Characteristics” [1].

7.2.1.2 A/342 Part 2: AC-4 System

A/342 Part 2 [23] standardizes the AC-4 audio system for use in the ATSC 3.0 Digital Television System. It describes the characteristics of the AC-4 audio system and establishes a set of constraints on ETSI TS 103 190-2 [60] for use within ATSC 3.0 broadcast emissions.

Some comparable capabilities in ATSC 1.0 are included in A/52 “Digital Audio Compression (AC-3) (E-AC-3) Standard” [5], A/53 Part 5 “AC-3 Audio System Characteristics,” and A/53 Part 6 “Enhanced AC-3 Audio System Characteristics” [1].

7.2.1.3 A/342 Part 3: MPEG-H System

A/342 Part 3 [9] standardizes the MPEG-H Audio system for use in the ATSC 3.0 Digital Television System. It describes the characteristics of the MPEG-H Audio system and establishes a set of constraints on MPEG-H Audio for use within ATSC 3.0 broadcast emissions.

Some comparable capabilities in ATSC 1.0 are included in A/52 “Digital Audio Compression (AC-3) (E-AC-3) Standard” [5], A/53 Part 5 “AC-3 Audio System Characteristics,” and A/53 Part 6 “Enhanced AC-3 Audio System Characteristics” [1].

7.2.2 Background

Programmer AC-4/MPEG-H audio encoding used for the ATSC 3.0 Television System may typically present the following:

- Composite or object-based soundtracks of minimally 2-channel stereo to a maximum of 7.1+4 immersive sound.
- A composite soundtrack typically contains dialog, music and effects.

- Use of audio “objects” may be included in the audio bitstream for efficient carriage of sound effects and user-selectable multiple languages, video description and additional commentators with selection based on the listener’s preference.
- When user-selectable language, description and commentator objects are provided as noted above, a music-and-effects-only bed is included that, when combined with the selected object(s), presents a complete personalized soundtrack to the listener.
- Audio Metadata is an integral element of the bitstream describing the characteristics of the audio Essence and for managing loudness and dynamic range control along with channel and object formatting and identification.
- ATSC 3.0 broadcasters and programmers should provide next generation audio (NGA) capable of being formatted to an ATSC 1.0 primary stereo or 5.1 soundtrack and a secondary soundtrack. This secondary track is composed of alternate language (AL) – or – video description (VDS) – or – emergency information audio³. The predetermined Content on this track is provided by the broadcaster or programmer and is for use in transmission and by downstream MVPD services in an ATSC 1.0 AC-3 audio distribution fashion, as a secondary program identification (PID) used for the Second Audio Program (SAP) channel.

Programmer Dolby AC-3 audio encoding used for the ATSC 1.0 Television System typically presents the following:

- Complete Main composite soundtracks of minimally 2-channel stereo (2/0 mode) to a maximum of 5.1 (3/2L) surround sound channels. A typical composite soundtrack contains dialog, music and effects in a complete mix format. This soundtrack is typically identified with MAIN program identification (PID) in distribution.
- An optional Alternate Language (AL) or Video Descriptive Service (VDS) composite soundtrack with emergency information audio priority. This soundtrack is typically a provider-remixed version of the primary soundtrack, using an alternate language, e.g., Spanish in lieu of English or adding video descriptions, typically using a version of the main language soundtrack but adding a narration of screen action during main-dialog silent passages. In the presence of a visual crawl, emergency information audio takes priority over AL and VDS Content and is presented to the listener. This soundtrack is typically identified with SECONDARY program identification (PID) in distribution.
- Alternate language, video description, and emergency crawl soundtracks are typically provided as dual-mono or stereo soundtracks and encoded in 2/0 channel mode, although they might be provided in surround and encoded in 3/2 or 3/2L formats. The choice is based on programming and bandwidth allocation factors.
- Audio Metadata is an integral element of the bitstream, describing the characteristics of the audio Essence, managing loudness and dynamic range control along with channel formatting and identification.

³ Emergency information audio is an audible presentation of visual emergency crawl information and should not be confused with Emergency Alert Audio.

7.2.3 Manual Audio Transcoding with AC-4 and MPEG-H

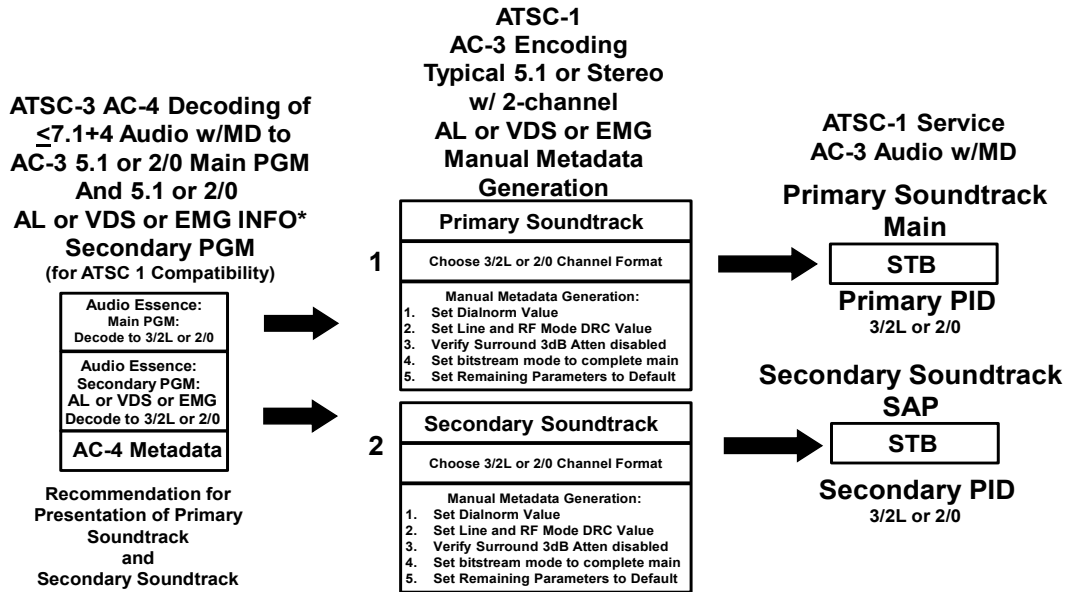

Figure 7.3 ATSC 3.0 to ATSC 1.0 audio conversion – manual transcoding with AC-4.

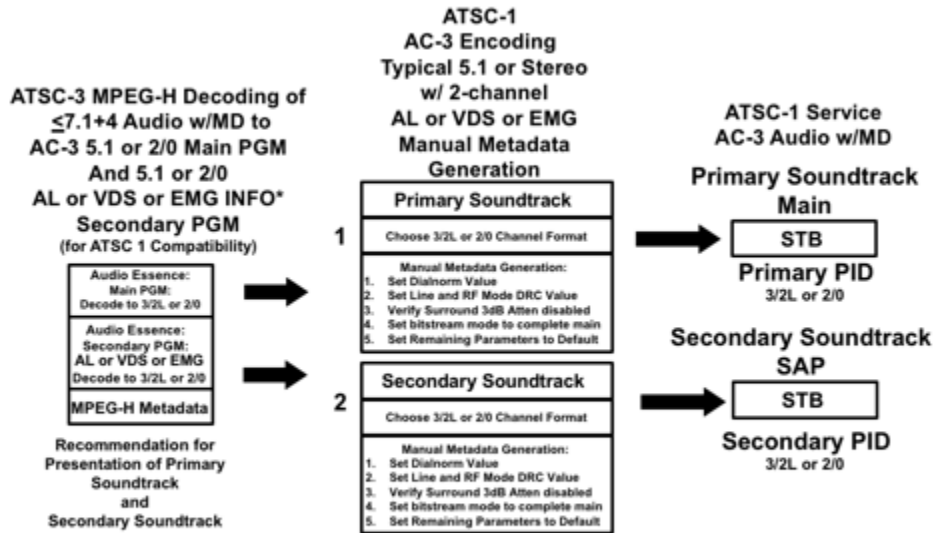

Figure 7.4 ATSC 3.0 to ATSC 1.0 audio conversion – manual transcoding with MPEG-H.

The following points describe Figure 7.3 and Figure 7.4 in further detail:

- These recommendations support only fixed loudness Metadata applications. (See Section 7 of A/85 [41])
- AC-4 or MPEG-H Metadata is present at the AC-4 or MPEG-H Decoder but does not pass automatically to the separate AC-3 encoders.
- Set the appropriate channel format on AC-4 or MPEG-H Decoder, based on the appropriate AC-3 channel mode. Note the decoder dialnorm and DRC values.
- Per the AC-4 or MPEG-H values, set channel format, dialnorm and DRC parameters and disable surround 3dB attenuation (default) on the AC-3 encoder.
- Set the bitstream mode to complete main; set or leave remaining values at default.
- ATSC 1.0 CALM Loudness compliance requires adherence to A/85 by ATSC 3.0 services.

7.2.4 Action Required for Manual Conversion of ATSC 3.0 AC-4 and MPEG-H Audio to ATSC 1.0 AC-3 Audio

7.2.4.1 Background

As of the publication date of this document, only a manual AC-4/MPEG-H Audio decoding and AC-3 encoding process was available for testing and documentation. This condition requires the process described in the following recommendation and is based on an examination of the source audio Essence and Metadata, without any automatic utilization of the accompanying Metadata during re-encoding.

During future implementation of next generation audio technology, it is likely an automatic transcoding process will eliminate the need for manual operation to perform conversion, replacing this process with an automatic workflow under the control of Metadata in the audio bitstreams.

7.2.4.2 Conditions

- These recommendations are based on providing ATSC 3.0 AC-4/MPEG-H audio programs that, when decoded, provide the elements needed for ATSC 1.0 AC-3 audio distribution. Doing so facilitates the creation of a primary PID main soundtrack and one additional secondary PID alternate language (AL), video descriptive service (VDS) or emergency information soundtrack used for downstream re-distributed SAP audio.
- These recommendations only support a fixed Metadata application enabling a static channel mode, static loudness, and fixed dynamic range parameters. For more information, see ATSC A/85 2013, Section 7 [41].
- To meet loudness requirements, these recommendations require previously performed:
 - Compliant loudness measurement and dialnorm authoring of the source AC-4 audio per ATSC A/85 [41].
 - Compliant loudness Metadata authoring of the source MPEG-H audio per ATSC A/85 [41].
- The AC-3 encoding recommendations that follow will preserve the loudness level of the AC-4/MPEG-H source audio. For more information, see ATSC A/85 2013, Section 5 [41].

7.2.4.3 Manual Audio Conversion of ATSC 3.0 AC-4 to ATSC 1.0 AC-3 Audio

7.2.4.3.1 ATSC 3.0 AC-4 Decoding

Perform the following on the AC-4 Decoder for the primary soundtrack:

- 1) Channel Mode:
 - a) Determine the channel operating mode of the ATSC 1.0, AC-3 audio bitstream that will be used for distribution and set the AC-4 decoder to this value. The AC-4

decoder will directly pass or render/downmix all elements of the audio soundtrack to conform to the required channel configuration for AC-3 encoding.

- b) For 3/2L (5.1) AC-3 encoding choose 5.1 as the AC-4 decoder channel value.
 - c) For 2/0 (stereo or dual mono) AC-3 encoding choose 2/0, 2.0, stereo or 2-channel as the AC-4 decoder channel value.
- 2) Dialnorm Loudness Control:
 - a) Note the dialnorm value of the ATSC 3.0, AC-4 audio, typically 24.
 - b) Set the AC-4 decoder to disable the dialnorm function. Ensure any other audio gain parameters of the decoder are set to unity. This process will present the audio to the downstream encoder without any change to the loudness of the Content.
 - 3) Dynamic Range Control (DRC):
 - a) Note the DRC profile of the ATSC 3.0, AC-4 Audio.
 - b) Set the AC-4 decoder to disable the DRC function. This will present the audio to the downstream encoder without any change to the dynamic range of the Content.
 - 4) Remaining Parameters:
 - a) Set or leave the remaining AC-4 decoder parameters at their default values.
 - b) If applicable, select the preferred language of the soundtrack.
 - 5) Additional Soundtrack:
 - a) Using a separate instance of decoding, repeat the process in steps 1-4 for any secondary soundtracks used for SAP.
 - b) If applicable, select the preferred language for the alternate language soundtrack, or select the VDS soundtrack and its language.

7.2.4.3.2 ATSC 1.0 AC-3 Encoding from AC-4 Decoding

Perform the following on the Main AC-3 Encoder for the primary soundtrack:

- 1) Channel Mode:
 - a) Set the channel operating mode of the ATSC 1.0, AC-3 audio bitstream to the format that will be used for distribution. This value should match the channel output format of the upstream AC-4 decoder.
 - i. Choose 3/2 and enable the LFE parameter for 5.1 audio.
 - ii. Choose 2/0 for stereo or dual mono 2-channel audio.
- 2) Dialnorm Loudness Control:
 - a) Set the AC-3 dialnorm value to the figure noted during AC-4 decoding.
- 3) Dynamic Range Control (DRC):
 - a) Set the AC-3 DRC to the Film Standard profile.
- 4) Remaining Parameters:
 - a) Set bitstream mode to Complete Main.
 - b) 3/2L encoding bitrates are 384 or 448 kb/s. Typical 2/0 encoding bitrate is 192 kb/s.
 - c) Confirm the surround 3dB attenuation parameter is disabled (default).
 - d) Set or leave the remaining AC-3 encoder parameters at their default values.
- 5) Additional Soundtrack:
 - a) Using a separate instance of encoding, repeat the process in steps 1-4 for any secondary soundtracks.

7.2.4.4 Manual Audio Conversion of ATSC 3.0 MPEG-H Audio to ATSC 1.0 AC-3 Audio

7.2.4.4.1 ATSC 3.0 MPEG-H Decoding:

Perform the following on the MPEG-H Audio Decoder for the primary soundtrack:

- 1) Target Layout:
 - a) Determine the channel operating mode of the ATSC 1.0, AC-3 audio bitstream that will be used for distribution and set the MPEG-H Audio decoder accordingly. The MPEG-H Audio decoder will directly pass or render/downmix all elements of the audio soundtrack to conform to the required channel configuration for AC-3 encoding.
 - i. For 3/2L (5.1) AC-3 encoding set the target layout to 6 (i.e., channel configuration 5.1) as input parameter to the MPEG-H Audio decoder.
 - ii. For 2/0 (stereo or dual mono) AC-3 encoding set the target layout to 2 (i.e., channel configuration 2.0/stereo) as input parameter to the MPEG-H Audio decoder.
- 2) Loudness Control:
 - a) Note the Content loudness present in the MPEG-H Metadata for the target layout configuration from 1.
 - b) Set the MPEG-H decoder to disable the loudness normalization function. Ensure any other audio gain parameters of the decoder are set to unity. This process will present the audio to the downstream encoder without any change to the loudness of the Content.
- 3) Dynamic Range Control (DRC):
 - a) Note the DRC profile of the ATSC 3.0, MPEG-H Audio.
 - b) Set the MPEG-H Audio decoder to disable the DRC function. This will present the audio to the downstream encoder without any change to the dynamic range of the Content.
- 4) Remaining Parameters:
 - a) Set or leave the remaining MPEG-H Audio decoder parameters at their default values.
 - b) If applicable, select the preferred language of the soundtrack.
- 5) Additional Soundtrack:
 - a) Using a separate instance of decoding, repeat the process in steps 1-4 for any secondary soundtracks used for SAP.
 - b) If applicable, select the preferred language for the alternate language soundtrack, or select the VDS soundtrack and its language.

7.2.4.4.2 ATSC 1.0 AC-3 Encoding from MPEG-H Decoding

Perform the following on the Main AC-3 Encoder for the primary soundtrack:

- 1) Channel Mode:
 - a) Set the channel operating mode of the ATSC 1.0, AC-3 audio bitstream to the format that will be used for distribution. This value should match the target layout of the upstream MPEG-H Audio decoder.
 - i. Choose 3/2 and enable the LFE parameter for 5.1 audio.
 - ii. Choose 2/0 for stereo or dual mono 2-channel audio.

- 2) Dialnorm Loudness Control:
 - a) Set the AC-3 dialnorm value to the Content loudness noted during MPEG-H Audio decoding.
- 3) Dynamic Range Control (DRC):
 - a) Set the AC-3 Line Mode and RF Mode DRC to the profiles noted during MPEG-H Audio decoding or to match local practice, typically Film Light and Film Standard.
- 4) Remaining Parameters:
 - a) Set bitstream mode to Complete Main.
 - b) 3/2L encoding bitrates are 384 or 448 kb/s. Typical 2/0 encoding bitrate is 192 kb/s.
 - c) Confirm the surround 3dB attenuation parameter is disabled (default).
 - d) Set or leave the remaining AC-3 encoder parameters at their default values.
- 5) Additional Soundtrack:
 - a) Using a separate instance of encoding, repeat the process in steps 1-4 for any secondary soundtracks.

7.3 Closed Captions and Subtitles Processing

7.3.1 A/343: Captions and Subtitles

ATSC A/343 “Closed Captions and Subtitles Standard” [42] defines the required technology for closed caption and subtitle tracks, which includes the Content. The packaging and timing, and the transport-dependent signaling over ROUTE-DASH, MMT and broadband transports are defined in A/331 [19] and the referenced DASH-IF Interoperability Points for ATSC 3.0.

ATSC A/343 defines the format as W3C “TTML Text and Image Profiles for Internet Media Subtitles and Captions (IMSC1)”. To ensure compatibility with MVPDs, 708/608 captions are recommended to be “tunneled” and signaled in accordance with SMPTE Recommended Practice RP 2052-11 2013 Section 5.13 [43] [44] when the IMSC1 Content is converted from 608/708. If the IMSC1 payload is constructed to include 608/708 captions, the conversion process is to simply extract the 608/708 timing and data per A/341 [30]. If the IMSC1 payload is constructed with only IMSC1 (not tunneled 608/708), then IMSC1 must be converted to 708 captions (with 608 compatibility bytes).

8. EMERGENCY ALERTING

As per Code of Federal Regulations TITLE 47 PART 11 “EAS” [59], broadcasters will continue to provide visual and audio alert messages relating to national, state and local emergencies in conformance with regulatory requirements in the United States.

In addition to the PART 11 requirements including CAP message information, ATSC 3.0 enables broadcasters to deliver advanced supplementary emergency-related Content such as advisories, warnings, evacuation maps, web pages, Amber alert details, and more. It should be understood that such information is supplemental in nature and that it might not be present in redistributed signals. In this case broadcasters might choose to provide the supplemental Content via their websites, and/or through an application on a consumer device, which could possibly utilize signaling through Video Watermark Emission or Audio Watermark Emission if the application is capable of receiving an ATSC 3.0 signal.

8.1 Audio and Video

The following diagram represents a key part of the delivery of EAS Content. During an emergency event, it is understood that the audio Content is completely replaced by the emergency audio Content. The rules allow the video to be completely replaced, or under specific circumstances, broadcasters are allowed to “burn in” text overlay to regular programming. This is shown in Figure 8.1 by the switch indicated before the audio encoder.

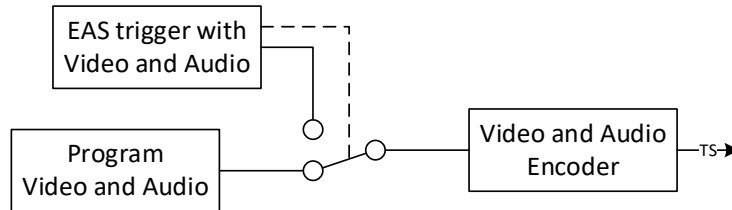

Figure 8.1 Content delivery of the EAS audio.

Additionally, video during an EAS event can be replaced or modified before, during, or after encoding so long as the Essence of the EAS event is being conveyed according to the PART 11 rules [59]. In the case where EAS messages are replaced after the encoder, video and audio are replaced downstream in the compressed domain.

9. SECURITY

9.1 A/360: ATSC 3.0 Security and Service Protection

The A/360 [45] standard specifies the mechanisms for security and service protection in ATSC 3.0 systems.

No conversion is needed since ATSC 1.0 A/70 [46] [47] has not been implemented, so therefore ATSC 1.0 systems do not have this capability. However, transmission via an MVPD system might have the MVPD system’s Content protection applied.

9.2 A/360: ATSC 3.0 Security and Service Protection (Cryptographic Signing)

The A/360 standard also specifies mechanisms for code signing and signaling signing. Systems receiving signed data should verify the signature(s) for correctness, but no conversion is necessary since ATSC 1.0 does not have this capability.

10. ATSC 3.0 AUDIO AND VIDEO WATERMARKS

10.1 A/335: Video Watermark Emission

The video watermark technology described in A/335 [49] provides the capability to embed ancillary data in the transmitted pixels of a video signal by modifying the luma component of the top two lines of pixels in active video. It is intended to provide a data path for its ancillary data payload that can readily survive changes in video compression data rate, transcoding to other video compression codecs, and delivery over legacy consumer HDMI interfaces.

A/335 video watermarking is backward compatible with ATSC 1.0 video coding and distribution. The information embedded in watermarks can be utilized by ATSC 3.0-ready sets, downstream of any Redistribution scenario. No modification or removal of video watermarking is necessary. Modification of any A/335 video watermarks is accomplished by overwriting the watermark data with black pixel values or new watermark data.

10.2 A/334: Audio Watermark Emission

A/334 [48] specifies the VP1 audio watermark for use with systems conforming to the ATSC 3.0 family of specifications. The document specifies the format in which the audio watermark resides in a PCM audio signal.

A/334 audio watermarking is backward compatible with ATSC 1.0 audio coding and distribution. The information embedded in watermarks can be utilized by ATSC 3.0-ready sets, downstream of any Redistribution scenario. No modification or removal of audio watermarking is necessary. Modification of any existing A/334 audio watermarks is described in ATSC Recommended Practice A/339 [50].

10.3 A/336: Content Recovery in Redistribution Scenarios

A/336 [40] specifies the data that is transported by the audio and video watermarks described in A/334 [48] and A/335 [49] and also how fingerprint technology can be used for Content identification. A/336 [40] also describes how to interpret the data delivered via watermark and how that data can be used to recover Content using a broadband connection in the receiver.

Fingerprint systems and ATSC 3.0 audio watermarks enable identification of Content in such a way that supplemental data or Content can be recovered via broadband. Neither fingerprint systems nor ATSC 3.0 audio watermarks are capable of directly transmitting supplemental data or Content.

ATSC 3.0 video watermarks also enable identification of Content in such a way that supplemental data or Content can be recovered via broadband. ATSC 3.0 video watermarks are further capable of directly carrying a limited amount of supplemental data (see A/336 for details).

Fingerprints and watermarks are designed to survive various transcodes and conversions of audio and video Content and thus, if they are present in an ATSC 3.0 emission, they can be expected to be present in an ATSC 1.0 emission that was generated from an ATSC 3.0 emission. In the event that such an ATSC 1.0 stream is ultimately rendered on an ATSC 3.0 device that has ATSC 3.0 watermark or fingerprint technology, the device will likely be capable of detecting the watermark or fingerprint, and it would be possible for that device to retrieve the supplemental data or Content.

It is possible for ATSC 3.0 audio and video watermarks to be erased or modified prior to final encoding for delivery to consumer homes. Refer to the previous sections on video and audio watermark emission and detection for more information.

11. INTERACTIVE CONTENT

ATSC 3.0 services may provide additional text and graphics Content elements that, at the option of a viewer with an interactive-capable TV receiver, can be overlaid on the video stream. These Content elements could be highly personalized or targeted to a specific user and would only be rendered on an individualized and personalized basis. However, in some cases, these Content elements might be generic rather than personalized, such as local weather forecast graphics, time and temperature information, sports scores and “banner ads”. For such generic Content elements, the broadcaster can decide to burn in those graphics elements when converting an ATSC 3.0 service to an ATSC 1.0 service.

Interactive elements are not directly related to any existing ATSC 1.0 specification, and although there are some aspects of interactivity included in ATSC 2.0, the scope of these recommendations do not address any such interactivity conversions from ATSC 3.0. It is recommended that all interactive elements get ignored in any conversion process from ATSC 3.0

to ATSC 1.0. Broadcasters who wish to maintain or generate generic Content elements as burned-in graphics should produce those elements as part of a pre-converted ATSC 3.0 to ATSC 1.0 stream.

12. REGIONAL SERVICE AVAILABILITY SIGNALING

Historically, broadcast frequency assignments and the standards for transmission over them have been relatively stable over time. In the United States, recent regulatory activities have caused the reallocation of frequencies, forcing broadcasters to move from one frequency to another and to combine services on a single frequency. These changes are not happening simultaneously and will continue for some time into the future. These transitions are further complicated by the emergent ATSC 3.0 standards where a broadcaster's ATSC 1.0 emission will be on a different RF frequency than the ATSC 3.0 emission.

ATSC has developed a signaling specification that contains information describing the availability of broadcast services over time within a broadcast region.⁴ Within this specification, ATSC has defined a Regional Service Availability Table that contains, for example, the RF channel that a broadcast service uses today, and the planned schedule for changes as that broadcast service moves from one RF channel to another. Broadcast receivers can use this information to help construct a list of available services. Additionally, receivers can use this information to schedule scans of all off-air RF channels so as to maintain an up-to-date service list.

While intended for use by off-air ATSC 3.0-capable consumer TV receivers, this information might also be useful for MVPDs that receive broadcasts off-air. Professional off-air receivers employed by MVPDs may use this information to schedule rescans as broadcast stations change RF frequencies. This might be of particular value to MVPDs who do not have more direct means to plan for broadcast station frequency changes.

⁴ A/200 – Candidate Standard for Regional Service Availability [55].

Annex A: Video Format Conversion Considerations

This Annex identifies and discusses some of the detailed considerations that may be helpful in the design or evaluation of conversions from ATSC 3.0 video formats (see A/341 “HEVC Video Coding” [30]) to ATSC 1.0 video formats (see A/53 Part 4 “MPEG-2 Video System Characteristics” [1] and A/72 (“Video System Characteristics of AVC in the ATSC Digital Television System” [35] for ATSC 1.0 video format information). Many of these considerations may also be informative to baseband video format conversions that might be performed in production or broadcasting.

A.1 VIDEO FORMAT CONVERSIONS

The A/341 Standard [30] allows a large variety of video representations and format parameters that ATSC 1.0 does not provide. For example, ATSC 3.0 might transmit High Dynamic Range (HDR) video signals representing either the PQ or HLG transfer characteristics with Wide Color Gamut (Rec. ITU-R BT.2100-2 [27]) and 10-bit sample depth. Standard Dynamic Range (SDR) video signals might have Wide Color Gamut (Rec. ITU-R BT.2020 [26]) or a Standard Color Gamut (Rec. ITU-R BT.709 [28]) and use either 10-bit or 8-bit sample depth. A large number of spatial resolutions up to 3840 by 2160 are possible using progressive scan formats, while legacy 1080i and 480i interlaced formats might also be used. In some cases, Spatial Scalable Coding might be used to provide base and enhancement layers with different resolutions. A/341 also supports multiple frame-rate options, including 100 and 120 fps High Frame Rate (HFR) video, which uses temporal sub-layering, might use temporal filtering, and might require appropriate conversion.

ATSC 1.0 also provides spatial resolution, scanning raster and frame rate flexibility, although with a more limited set of parameters. Hence systems that perform a generalized ATSC 3.0 to ATSC 1.0 video format conversion must deal with an extremely large number of possible ATSC 3.0 input formats that must be converted to one of the many possible ATSC 1.0 output formats.

Conversions need to consider speed/latency, quality, accuracy, and the prioritization among these factors when processing the ATSC 3.0 signals and services. A conversion of an ATSC 3.0 signal into an ATSC 1.0 signal inherently reduces the amount of information carried in the output signal. Encoding of the additional information can add to computational complexity of the conversion. Reducing computational complexity before encoding through the order and/or combination of pre-processing and pre-filtering conversion steps needs to be considered. Examples of this are reducing spatial resolution, reducing temporal frame rates, and combining mapping operations for transfer characteristics and color gamut into the SDR BT.709 color volume.

Quality and accuracy are pertinent to the retention of the remaining information in the output ATSC 1.0 signal. The order and/or combinations of conversion steps and the number of re-encodes in the workflow path can introduce aliasing, quantization, brightness, or color gamut artifacts, all of which can affect quality and accuracy. These artifacts can

then get propagated and processed at each successive conversion step, reducing the quality and accuracy of the output content within the bounds of the output format constraints. Examples of processes which assist to preserve quality and accuracy are: preserving bit depth as far into the conversion process as possible to avoid truncation effects on quantization coefficients; avoiding inverse tone mapping operations before mapping of the color gamut to a BT.709 space; and performing spatial and temporal pre-filtering operations on the progressive scan format prior to subsampling to create an interlaced raster format. Designers and users of conversion processes and equipment should consider the impacts of the scalability, volume, ordering, combination, and aggregation of conversion steps on the latency, quality, and accuracy of the processed content.

Depending upon the specifics of the transmitted ATSC 3.0 video format and the desired output ATSC 1.0 video format, the conversions of many aspects of the video signal may be required, including:

- Spatial resolution
- Spatial Scalable decoding
- HDR to SDR
- Tone mapping from a Wide Color Gamut to a narrower Rec. ITU-R BT.709 color gamut
- Frame rate
- Temporal sub-layering⁵ and temporal filtering recovery
- Progressive/Interlaced Scan Conversion
- Aspect Ratio (which may also involve spatial resolution)
- Color Component Signals
- Signal Range
- Sample Bit depth

A further consideration in the conversion of ATSC 3.0 video to ATSC 1.0 formats is the optional use of Spatial Scalable Coding in ATSC 3.0. If the ATSC 3.0 signal is encoded with Spatial Scalable Coding, either the base layer or the reconstructed full resolution video might be selected for conversion (these options are presented in Section A.3). SL-HDR1 might also be used in conjunction with Spatial Scalable Coding, so that the base and enhancement layers might have different transfer characteristics and color space parameters (see Section A.5). Temporal sub-layering is used for HFR video that would otherwise exceed the capabilities of an HEVC Level 5.1 decoder (e.g., 2160p/120 fps video). By decoding the pictures of temporal sub-layer 0 only, an HEVC Level 5.1 decoder can recover the video with exactly half of the original frame rate. In the case that all of the pictures of High Frame Rate video can be decoded by an HEVC Level 5.1 decoder (e.g., 1080p/120 fps video), the decoder has access to all of the pictures and can convert the frame rate as necessary by dropping frames, applying a weighted averaging of frames, or

⁵ Due to the required use of Temporal sub-layering for 2160p/119.88 in ATSC 3.0, there is no need for frame rate conversion when selecting temporal sub-layer 0 (2160p/59.94). Broadcasters may optionally use Temporal sub-layering at lower spatial resolutions to provide the same benefit. The use of 120.00 fps or 60 fps ATSC 3.0 Essence will need frame rate conversion to deliver a 59.94 fps ATSC 1.0 signal.

by some other proprietary means. When an HEVC Level 5.2 decoder decodes HFR video, temporal filtering recovery might be necessary for proper recovery of all of the frames.

In situations where a broadcaster can control or specify the video format parameters for both ATSC 3.0 and ATSC 1.0 services it is recommended to judiciously choose both ATSC 3.0 and ATSC 1.0 video format parameters that are identical or related to one another. Table A.1 shows the most widely used ATSC 1.0 video formats and some examples of ATSC 3.0 formats that are highly compatible with those ATSC 1.0 formats, along with the processes required for the video format conversion.

In situations where an ATSC 1.0 service provider has no control of the ATSC 3.0 video format parameters, it is recommended to judiciously choose an ATSC 1.0 video format that is identical or related to the ATSC 3.0 video parameters. Table A.2 lists some of the likely possibilities for ATSC 3.0 video formats and some examples of simply related ATSC 1.0 video formats, along with the processes required for video format conversion. Note that while not in widespread use today and therefore not shown in Table A.2, the 480p 59.94 fps format capability of ATSC 1.0 might be a useful option in the conversion of ATSC 3.0 services to ATSC 1.0 services.

Table A.1 Conversions of Some Anticipated ATSC 3.0 Video Formats to Associated ATSC 1.0 Video Formats

ATSC 3.0 Input Format	Resolution Change	De-inter-lace	Frame Rate	Transfer Characteristic	Color Gamut	Aspect Ratio	Interlace	ATSC 1.0 Output Format
2160p HDR 120.0 fps	X		X	X	X		X	1080i 59.94 fps
	X		X	X	X			720p 59.94 fps
2160p HDR 60.0 fps	X		X	X	X		X	1080i 59.94 fps
	X		X	X	X			720p 59.94 fps
2160p HDR 59.94 fps	X			X	X		X	1080i 59.94 fps
	X			X	X			720p 59.94 fps
1080p HDR 120.0 fps			X	X			X	1080i 59.94 fps
	X		X	X	X			720p 59.94 fps
1080p HDR 60.0 fps			X	X	X		X	1080i 59.94 fps
	X		X	X	X			720p 59.94 fps
1080p HDR 59.94 fps				X	X		X	1080i 59.94 fps
	X			X	X			720p 59.94 fps
1080p SDR 59.94 fps							X	1080i 59.94 fps
	X							720p 59.94 fps
1080i SDR 59.94 fps								1080i 59.94 fps
	X	X						720p 59.94 fps
	X	X					X	480i wide 59.94 fps
	X	X				X	X	480i 59.94 fps
720p SDR 59.94 fps								720p 59.94 fps
	X						X	480i wide 59.94 fps
	X					X	X	480i 59.94 fps
480p SDR 59.94 fps								480p 59.94 fps
						X	X	480i 59.94 fps
480i SDR 59.94 fps								480i 59.94 fps

Table A.2 Conversions of Anticipated ATSC 3.0 Video Formats to Associated ATSC 1.0 Video Formats

ATSC 3.0 Input Format	De-interlace	Resolution Change	Frame Rate ⁶	Transfer Characteristic ⁷	Color Gamut ⁸	Aspect Ratio ⁹	Interlace	ATSC 1.0 Output Format
1080i/SDR/59.94i	-----Native Format----->							1080i/SDR/59.94
1080p/SDR/59.94						X		
1080p/HDR/59.94				X	X		X	
1080p/HDR/119.88			X	X	X		X	
2160p/SDR/59.94		X					X	
2160p/HDR/59.94		X		X	X		X	
2160p/HDR/119.88		X		X	X		X	
720p/SDR/59.94	-----Native Format----->							720p/SDR/59.94
1080i/SDR/59.94	X	X						
1080p/SDR/59.94		X						
1080p/HDR/59.94		X		X	X			
1080p/HDR/119.88		X	X	X	X			
2160p/SDR/59.94		X						
2160p/HDR/59.94		X		X	X			
2160p/HDR/119.88		X		X	X			
480p/SDR/59.94	-----Native Format----->							480p/SDR/59.94 ¹⁰
720p/SDR/59.94		X						
1080i/SDR/59.94	X	X					X	
1080p/SDR/59.94		X						
1080p/HDR/59.94		X		X	X			
1080p/HDR/119.88		X	X	X	X			
2160p/SDR/59.94		X						
2160p/HDR/59.94		X		X	X			
2160p/HDR/119.88		X		X	X			
480i/SDR/59.94	-----Native Format----->							480i/SDR/59.94
480p/SDR/59.94						X	X	
720p/SDR/59.94		X				X	X	
1080i/SDR/59.94	X	X				X	X	
1080p/SDR/59.94		X				X	X	

⁶ Integer frame rates are possible ATSC 3.0 emission formats but their conversion has not been considered in the table. Note that while integer frame rates are described in the ATSC 3.0 standard, at the time of this writing, they are not used in broadcast emissions.

⁷ Transfer characteristic changes include video sample bit depth changes (10-bit or 12-bit to 8-bit) as well as conversion from full range values to narrow range values if necessary.

⁸ Color gamut change includes conversion from ICpCt to YPrPb if required.

⁹ 16:9 default aspect ratio of all formats except 480i, which is assumed to be 4:3.

¹⁰ Although not currently in widespread use at the time of this writing, utilization of the 480p/SDR/59.94 format capability in ATSC 1.0 might be helpful during the transition to ATSC 3.0.

ATSC 3.0 Input Format	De-interlace	Resolution Change	Frame Rate ⁶	Transfer Characteristic ⁷	Color Gamut ⁸	Aspect Ratio ⁹	Interlace	ATSC 1.0 Output Format
1080p/HDR/59.94		X		X	X	X	X	
1080p/HDR/119.88		X	X	X	X	X	X	
2160p/SDR/59.94		X				X	X	
2160p/HDR/59.94		X		X	X	X	X	
2160p/HDR/119.88		X		X	X	X	X	

A.2 PRACTICAL IMPLEMENTATION AND USER CONSIDERATIONS

Conversion system designers will have to consider and evaluate the scope of conversion functions that are needed, determine the order in which conversion steps are applied and make appropriate quality/complexity design decisions for each of the conversion steps. Their choices will be influenced by competitive marketplace factors that will likely change over time. Similarly, conversion system users will have to consider the quality and complexity of different solutions with respect to their specific format conversion requirements. The quality and complexity of conversion systems that are available in the marketplace may also influence broadcasters' choice of ATSC 3.0 video formats and conversion system users' choice of ATSC 1.0 formats.

Because of the number of conversion aspects involved and the wide range of quality/complexity choices available, the following sections are intended to serve as an informative resource that highlights some of the many considerations that conversion system designers and users should be aware of.

A.3 CONVERSION FROM A SINGLE SPATIAL LAYER ENCODED ATSC 3.0 SIGNAL

Taking the most straightforward case of converting from a single-layer encoded ATSC 3.0 signal to an ATSC 1.0 signal, one example video processing signal flow diagram is shown in Figure A.2. This example is based on performing spatial resolution conversion as a first step, which allows all subsequent processing steps to benefit from using the reduced resolution's slower pixel rate and lower computation/complexity.

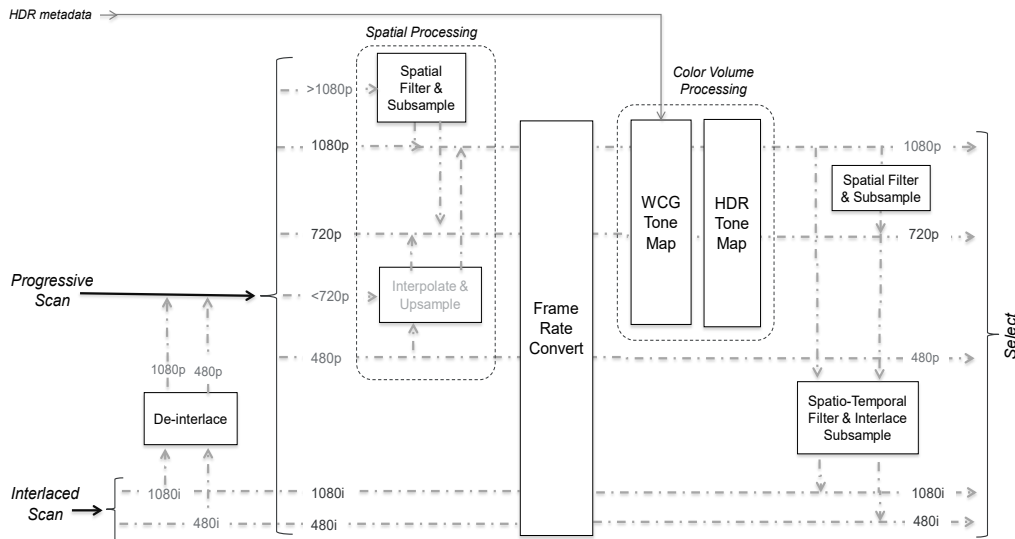

Figure A.1 Example video format conversion flow with spatial conversion followed by frame rate conversion and color conversion.

The sequence of conversions shown in Figure A.1 allows lower-resolution images to be processed by the subsequent frame rate conversion and color volume processing processes, reducing their required speed of computations.

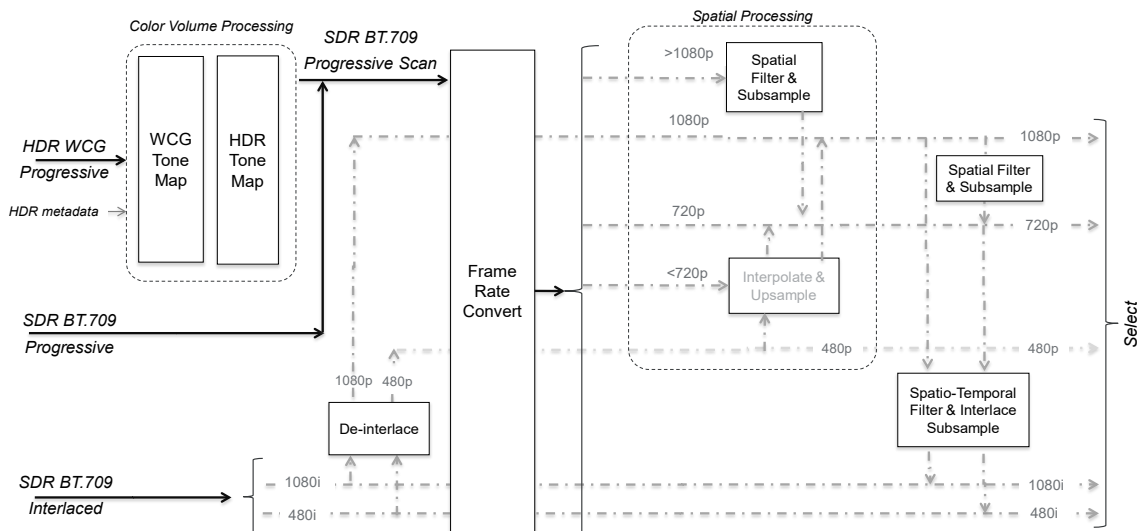

Figure A.2 Example video format conversion flow with color and frame rate conversion followed by spatial resolution conversion.

The example in Figure A.2 shows a conversion flow where color volume processing and frame rate conversion are performed using the highest available input resolution, followed by subsequent conversion of spatial resolution. This sequence of conversions allows high precision in the representation of colors and for determining motion in the scene.

A.3.1 Spatial Resolution(s)

If an ATSC 3.0 spatial resolution and raster format is identical to the desired ATSC 1.0 spatial resolution and raster format, then no spatial resolution conversion is needed. The ATSC 1.0 formats are represented by the horizontal signal flow lines in Figure A.2 that correspond to ATSC 1.0 formats (1080p, 720p, 480p, 1080i and 480i) at any frame rate. Note that in some conversion flows, it might be beneficial to use 1080p 60.0/59.94 fps as an intermediate format for other conversion steps that are performed prior to interlacing, and producing a 1080i format.

If an ATSC 3.0 video format is higher-resolution than the desired ATSC 1.0 video format, the ATSC 3.0 format component signals (e.g., YCrCb or ICtCp) should be spatially filtered and subsampled (i.e. creating samples at the output resolution) to produce the desired ATSC 1.0 spatial format. In order to maintain the best accuracy for subsequent processing steps, it is preferable to maintain a progressive scan raster with at least the bit depth of the original ATSC 3.0 format. There are many considerations and tradeoffs in pre-filter performance and complexity, including the number and precision of coefficients and computation; however, those details are beyond the scope of this document.

Although an ATSC 3.0 video format may be lower-resolution than the desired ATSC 1.0 video format, this is not anticipated to be a likely situation when single-layer encoding is used (see Section A.4 for considerations with Spatial Scalable Encoding). However, if an ATSC 3.0 video format is lower-resolution than the desired ATSC 1.0 video format, the ATSC 3.0 format component signals (e.g., YCbCr) should be spatially interpolated and upsampled (i.e. creating samples at the output resolution) to produce the desired ATSC 1.0 spatial format. There are many considerations and tradeoffs in interpolation filter performance and complexity, including the number and precision of coefficients and computation, which can impact the sharpness of edges and the introduction of “ringing”; however, those details are beyond the scope of this document.

A.3.2 Interlaced to Progressive Scan Conversion (De-interlacing)

Depending upon the video formats of the ATSC 3.0 service and the desired video format of the ATSC 1.0 service, conversion between progressive and interlaced scanning rasters may need to be performed.

- 1) In cases where an ATSC 3.0 interlaced video format is identical to the desired ATSC 1.0 interlaced format, no raster scanning conversion will need to be performed. Note that frame rate conversion might still be required. This is shown in Figure A.2 by the 1080i horizontal line that passes through the Frame Rate Conversion block.
- 2) In cases where the ATSC 3.0 format is interlaced scan (e.g., 1080i) and a progressive scan ATSC 1.0 is desired (e.g., 720p or 480p), de-interlacing must be performed. The highest quality de-interlacing approaches often use motion-compensated algorithms, but simpler spatial-temporal adaptive filtering and fixed

spatial-temporal filtering approaches are also widely used. There are many possible conversion techniques that span a wide range of complexity, latency and picture quality tradeoffs; however, those details are beyond the scope of this document. Note that frame rate conversion might still be required. This is shown in Figure A.2 by the 720p and 480p horizontal lines that pass through the Frame Rate Conversion block.

- 3) In cases where an interlaced ATSC 3.0 video format (e.g., 1080i) must be converted to an ATSC 1.0 interlaced format (e.g., 480i), de-interlacing might be performed to create an intermediate progressive scan format for subsequent conversion steps, including progressive-to-interlaced scan conversion (see Section A.3.7 Progressive to Interlaced Scan Conversion). Note that frame rate conversion might still be required. This approach is shown in the example of Figure A.2 by the 1080p and 480p horizontal lines that pass through the Frame Rate Conversion block and are subsequently interlaced. There are other conversion techniques that span a wide range of complexity, latency and picture quality tradeoffs; however, those details are beyond the scope of this document.

A.3.3 Frame Rate Conversion

ATSC 3.0 video streams may be at a High Frame Rate (HFR) or any of the standard frame rates used in ATSC 1.0. HFR video may include temporal sub-layering, which facilitates one-half rate conversion. However, frame rate conversions among other rates may also be required. In the example of Figure A.2, frame rate conversion is shown as the second step of the conversion process, which may be performed at a convenient spatial resolution.

To achieve a one-half rate conversion of HFR video that includes temporal sub-layering, the decoder might discard (or not decode the compressed bitstream portions that represent) pictures of sub-layer 1. Where the HDR video includes temporal filtering, the result already includes processing to reduce the strobing artifact that can arise from dropping frames.

Where the HFR video includes temporal filtering, the result already includes processing to reduce the strobing artifact that can arise from dropping frames. In this case, using video from sub-layer 0 alone might be sufficient. Where the HFR video does not include temporal filtering, dropping pictures of sub-layer 1 is likely to result in strobing artifacts. A motion-compensated temporal filtering or similar process might be used to reduce strobing. This process may be applied to just the frames of sub-layer 0; however, applying the process to all of the frames (sub-layers 0 and 1) can produce superior results. The details of motion-compensated temporal filtering are beyond the scope of this document. Note that for UHD HFR video, an HEVC Level 5.2 decoder is needed in order to decode all of the frames.

Frame rate conversions might also involve integer frame rate ATSC 3.0 sources (e.g., 120.0 or 60.0 fps) and fractional frame rate ATSC 1.0 outputs (e.g., 59.94 fps). There are many possible techniques for changing the frame rate by 1000/1001, with different tradeoffs among quality, complexity, latency and other factors. At one end of the scale, there are complex motion interpolation techniques that have been developed for broadcast quality 59.94 ↔ 50 fps applications. At the other end of the scale, simple frame drop (or repeat) techniques might be deemed adequate in some use cases (e.g. 60.0 fps to 59.94 fps). Note that while possible, it is not a widely anticipated use case to have fractional frame rate ATSC 3.0 signals as a source for integer frame rate ATSC 1.0 signals.

Although ATSC 1.0 includes 30.00, 29.98, 24.00 and 23.98 fps progressive scan formats, these formats are not in widespread use and therefore before planning conversions to ATSC 1.0 services that use these formats, careful evaluation of downstream ATSC 1.0 receiver capabilities should be made.

In order to minimize latency and temporal artifacts that might arise when frame rate conversion is required, it might be preferable to perform the frame rate conversion after or as an integral part of other processing steps that use temporal processing (e.g., de-interlacing).

A.3.4 Transfer Characteristic and Color Gamut Conversions

ATSC 3.0 video signals might be High Dynamic Range (HDR) using the Perceptual Quantization (PQ) or the Hybrid-log Gamma (HLG) transfer characteristic or Standard Dynamic Range (SDR). All HDR signals are represented in the Rec. ITU-R BT.2100-2 Color Gamut. ATSC 3.0 SDR video signals might utilize Rec. ITU-R BT.2020 Wide Color Gamut or Rec. ITU-R BT.709 Standard Color Gamut. Additionally, an SDR video signal might include SL-HDR1 dynamic Metadata that guides the reconstruction of an HDR WCG video signal from an SDR Rec. ITU-R BT.709 compatible representation (see Section 1.3 in [28]). ATSC 1.0 signals must be SDR Rec. ITU-R BT.709, thus any ATSC 3.0 native-format HDR or WCG signals must be converted to the SDR transfer characteristic and/or tone-mapped to the Rec. ITU-R BT.709 color space.

Rep. ITU-R BT.2390-6 “High Dynamic Range Television for Production and International Programme Exchange” [52] and Rep. ITU-R BT.2408-2 “Guidance for operational practices in HDR television production,” [51] along with Rep. ITU-R BT.2446-0 “Methods for conversion of high dynamic range content to standard dynamic range content and vice-versa,” [62] contain guidance and best practices related to conversion among different HDR transfer characteristics including conversion to and from SDR formats. For this recommended practice document, Section 7.3 (“SDR-HDR and HDR-SDR format conversion”) and Section 7.4 (“SDR-HDR-SDR “Round-Tripping”) of Rep. ITU-R BT.2408-2 are of particular relevance in creating the converted SDR content. While the subjects of HDR to SDR conversion and Wide Color Gamut tone-mapping to the smaller Rec. ITU-R BT.709 color gamut are not addressed in Rep. ITU-R BT.2390-6, that document has basic information and approaches to HDR system conversions which may be informative. In addition, recommended practices for color gamut conversion can be found in Rep. ITU-R BT.2407-0 “Colour gamut conversion from Recommendation ITU-R BT.2020 to Recommendation ITU-R BT.709” [63].

When converting from HDR formats to SDR the signal level for diffuse white in HDR should map to the signal level for diffuse white in SDR. This will ensure no abrupt changes in brightness when switching between natively-produced SDR and SDR converted from HDR. Signal levels for diffuse white in HDR signals are recommended in Rep. ITU-R BT.2408-2 [51]. The signal level for diffuse white in SDR is defined by operational practice and might vary between genres. Mapping the diffuse white level might be achieved by scaling the linear (not NON-linear) light signal, and applying an adjustment to account for the variation in accommodation of the eye when viewing HDR and SDR pictures. Highlights above diffuse white in the HDR signal must be mapped to the much more limited range afforded above diffuse white in SDR. Highlight mapping might be implemented by applying a compressive non-linearity above diffuse white in a look-up

table (LUT), but other techniques, including adaptive signal processing, are also available. It is critical that during conversion, signal mappings for HDR to SDR preserve perceptual detail at/below SDR legal range to get consistent conversion results due to many reception variables such as broadcast encoders that clip at legal range, or consumer TVs that do the same. When converting from PQ to SDR the luminance of the SDR display should be taken to be the luminance of a reference monitor, typically as specified in Rep. ITU-R BT.2035 [53].

Mapping from HDR WCG Rec. ITU-R BT.2100-2 to SDR Rec. ITU-R BT.709 might be beneficially combined as a single step, since the overall color volume of the input ATSC 3.0 signal must be mapped into the SDR Rec. ITU-R BT.709 color volume of ATSC 1.0. (Note that if the ATSC 3.0 HDR video format utilizes the PQ transfer characteristic with ICtCp components and/or Full-Range signal representation, the color volume transformation should also include conversion to the YCrCb color components and Narrow-Range signal representation used in all ATSC 1.0 video formats.)

A.3.5 Color Components

If an ATSC 3.0 signal is HDR video represented in the PQ transfer characteristic with ICtCp color components, the conversion of color components should be performed in conjunction with transfer characteristic and/or color gamut conversion (see Section A.3.4 Transfer Characteristic and Color Gamut Conversions).

A.3.6 Signal Range (Full-Range to Narrow-Range)

If an ATSC 3.0 signal is HDR video represented in the PQ transfer characteristic with Full-Range, the Conversion of Full-Range to Narrow-Range signals might be performed in conjunction with transfer characteristic and/or color gamut conversion (see Section A.3.4 Transfer Characteristic and Color Gamut Conversions).

A.3.7 Progressive to Interlaced Scan Conversion

When converting from any progressive scan format to an interlaced scan format, spatial and temporal pre-filtering should be applied before subsampling to an interlaced raster, in order to avoid spatio-temporal aliasing artifacts. In cases where the ATSC 3.0 video format is progressive scan and an interlaced scan ATSC 1.0 format (e.g., 1080i or 480i) is desired, interlace spatio-temporal subsampling can be performed to create an interlaced raster (1080i or 480i) format. Since it is preferable to perform other format conversion steps using a progressive scan representation, generating an interlaced signal is often the final step of a conversion process. In order to maintain good picture quality and avoid excessive interlace artifacts, proper spatio-temporal filtering should be performed before subsampling. High-quality filtering should consider the unique characteristics of temporal sampling and human perception, which generally results in filtering that tends to mimic the light integration in an interlaced sensor. Note that other conversions involving temporal processing (e.g., frame rate conversion) might be performed in combination.

Although it is not anticipated to be a common situation, in cases where the ATSC 3.0 progressive scan resolution is lower than the desired ATSC 1.0 interlaced scan resolution (e.g., a 720p format converted to a 1080i format), spatial interpolation to a progressive scan raster should be performed, followed by spatio-temporal filtering and subsampling.

In the case of a producing a 720p (or 480p) format, a final stage of spatial filtering or subsampling might be applied. (Note that this also could have been performed directly in the first processing stage. The advantage of using the 1080p format is to use the greatest accuracy for subsequent processing.)

A.3.8 Sample Bit Depth

ATSC 3.0 video might be coded with 8-bit sample depth or with 10-bit sample depth. All HDR formats are coded with 10-bit sample depth. (The PQ transfer characteristic may have a Full-Range or Narrow-Range representation.) The HLG transfer characteristic only uses a Narrow-Range representation. SDR signals might be coded with 10-bit or 8-bit depth using a Narrow-Range representation.

ATSC 1.0 signals only have an SDR transfer characteristic and must be coded at 8-bit sample depth, thus any 10-bit samples must be converted to 8-bit samples.

In cases where a Narrow-Range representation is maintained, sample bit-depth conversion might be performed by simply truncating the two least significant bits. However, when converting from 10-bit samples in Full Range to 8-bit samples in Narrow-Range, appropriate scaling and offset must be performed. Since this condition arises only in the case of a PQ HDR format, it might be advantageous to perform the Full-Range to Narrow-Range conversion as part of the transfer characteristic and Color Space conversion process.

In order to preserve the most precise representation of video samples throughout various conversion processes, sample bit depth should not be reduced to 8 bits until the final stages of conversion. Techniques of reducing sample bit depth range from various dithering algorithms to simple truncation, which will have different effects on the visibility of “contouring”, particularly in large area regions with smooth signal gradients in luminance and/or chrominance; however, quality/complexity tradeoffs of various algorithms are beyond the scope of this document

A.3.9 Aspect Ratio

Anticipating that downstream aspect ratio conversions might be performed, broadcasters should include Active Format Description (AFD) whenever possible in the ATSC 3.0 signal.

Aspect ratio conversion is not needed when the aspect ratios of an ATSC 3.0 video format and the desired ATSC 1.0 video format are the same. For example, a 16:9 aspect ratio ATSC 3.0 service might be converted to a different resolution 16:9 aspect ratio ATSC 1.0 service. Note that it might subsequently need to be converted to a 4:3 aspect ratio service. Although aspect ratio conversion is not needed, when converting from ATSC 3.0 to ATSC 1.0, the AFD information should be extracted from the ATSC 3.0 signal and re-inserted into the ATSC 1.0 signal in order to inform any subsequent downstream aspect ratio conversion.

In the case where the aspect ratio of an ATSC 3.0 service differs from the aspect ratio of the desired ATSC 1.0, service, the aspect ratio needs to be converted. For example, a 16:9 ATSC 3.0 service may be converted to a 4:3 ATSC 1.0 service. When aspect ratio conversion is performed, conversions should follow the recommendations found in CEA CEB16 [55]. If the aspect ratio is altered, the AFD information should be updated and inserted into the ATSC 1.0 signal.

When aspect ratio conversion is performed at the same vertical resolution, simple image cropping can be used (e.g. “center cut”). Aspect ratio conversion might also be performed in conjunction with a spatial resolution and/or scanning format change, which warrants additional considerations.

In cases where aspect ratio conversion and resolution change are performed between progressive scan formats (e.g. 16:9 1080p to 4:3 480p), the combined conversion might be performed as a spatial resolution conversion with associated cropping; see Section A.3.1 for details.

In cases where aspect ratio conversion and resolution change involve interlaced formats, de-interlacing and/or interlacing conversion techniques might be applied; see Section A.3.2 for details. (For example, in the case of converting 16:9 1080i to 4:3 480i, the input format might be de-interlaced to a progressive format, followed by spatial resolution conversion and cropping, and finally filtering and subsampling to form the interlaced output format.) Simpler raster interpolation approaches are also available, but there will be quality/complexity tradeoffs among various algorithms.

In all cases, the spatial conversion of the ATSC 3.0 image data should follow the recommendation of SMPTE ST 2016-1 Format for Active Format Description and Bar data [31], specifically Table 2, Video Format Information, on the line numbering and pixel numbering for all supported image formats. Note that the line numbering and pixel numbering for UHD formats is not specified in SMPTE ST 2016 but can be found in SMPTE ST 2036-1 [56]. Note also that AFD signaling in subsequent downstream cable transmission may be as specified in SCTE 128-1 for AVC coding [57], or SCTE 215-1 for HEVC coding [58].

A.4 CONVERSION FROM A TWO-LAYER SPATIALLY SCALABLE ENCODED ATSC 3.0 SIGNAL

When the ATSC 3.0 signal employs SHVC scalable coding, the base layer video signal or the reconstructed full-resolution video signal might be used for conversion to ATSC 1.0 format, as shown in the example of Figure A.3.

If the intended ATSC 1.0 video service is of a *higher* resolution than that available from the ATSC 3.0 base layer, the best picture quality will be achieved by decoding both the base layer and the enhancement layer, reconstructing the full-resolution video signal and then subsequently performing the necessary video format conversion processing steps. If, however, the base layer is of the same or higher resolution than the intended ATSC 1.0 signal, it is sufficient to decode only the base layer and use this as the source image for conversion to the ATSC 1.0 video signal.

After the initial spatial resolution conversion, the remaining conversion aspects described for single-layer encoding should be similarly considered.

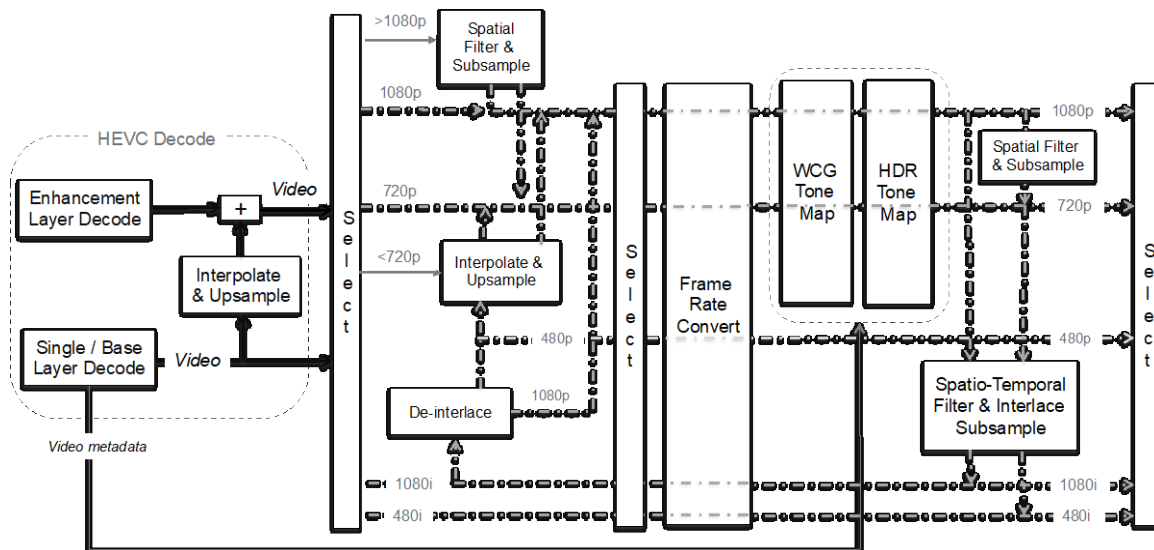

Figure A.3 Example flow for conversion of ATSC 3.0 streams to ATSC 1.0 streams.

A.5 CONVERSION FROM AN SL-HDR1 ENCODED ATSC 3.0 SIGNAL

When the ATSC 3.0 video signal includes an SL-HDR1 representation, the video stream might be decoded to either an HDR/WCG signal or an SDR Rec. ITU-R BT.709 baseband signal. Conversions might significantly reduce complexity by decoding the SL-HDR1 video as SDR / Rec. ITU-R BT.709 (i.e. ignoring the SL-HDR1 reconstruction Metadata) and bypassing HDR transfer characteristic and/or color gamut conversions. This is also true when SL-HDR1 is used in combination with SHVC Spatial Scalability.

A.6 INFORMATIONAL REFERENCES ON DE-INTERLACING AND SCAN CONVERSION

- “An Efficient Motion Adaptive De-interlacing and Its VLSI Architecture Design,” Hongbin Sun, Nanning Zheng, Chenyang Ge, 2008 IEEE Computer Society Annual Symposium on VLSI, 7-9 April 2008.
- “Progress in motion estimation for consumer video format conversion,” G. de Haan, IEEE Transactions on Consumer Electronics, Year: 2000, Volume: 46, Issue: 3.
- “Motion Compensated De-Interlacing: The Key to the Digital Video Transition,” Jed Deame, 141st SMPTE Technical Conference and Exhibition, 1999.
- “A method of de-interlacing with motion compensated interpolation,” K. Sugiyama ; H. Nakamura, 1999 Digest of Technical Papers. International Conference on Consumer Electronics (Cat. No.99CH36277), 22-24 June 1999.
- “Variable-raster multiresolution video processing with motion compensation techniques,” J.-R. Ohm, K. Rummler. Proceedings of International Conference on Image Processing, 26-29 Oct. 1997.
- “Advanced Approach to Universal Video Format Conversion,” Clarence Hau, Kevin Stec, Proceedings 137th SMPTE Technical Conference and World Media Expo; 6-9 Sept. 1995.
- “Video format conversions between HDTV systems,” D. -H. Lee; J. -S. Park; Y. -G. Kim, IEEE Transactions on Consumer Electronics, 1993, Volume: 39, Issue: 3.

“ATV/NTSC format converters,” W. Bretl, IEEE Transactions on Consumer Electronics, Year: 1990, Volume: 36, Issue: 3.

A.7 INFORMATIONAL REFERENCES ON FRAME RATE CONVERSION

“High Frame Rate Video Conversion,” Paola Hobson, SMPTE Motion Imaging Journal, Year: 2015, Volume: 124, Issue: 7.

“Advanced Frame Rate Conversion and Performance Evaluation,” P. Blanchfield; D. Wang; A. Vincent; F. Speranza; R. Renaud, SMPTE Motion Imaging Journal, Year: 2006, Volume: 115, Issue: 4.

“An adaptive true motion estimation algorithm for frame rate conversion of high definition video and its hardware implementations,” Mert Cetin; Ilker Hamzaoglu, IEEE Transactions on Consumer Electronics, Year: 2011, Volume: 57, Issue: 2.

– End of Document –